



Model 2800
Leveling System
Parts Book
(SN 2800-1001 thru 2800-1102)

(D010413MDH01C)



2800 Leveling System
for 2188 and 2388 CASE-IH Combines

TABLE OF CONTENTS

1 GENERAL INFORMATION	1-3
Serial Number Location	1-3
Text Format and Illustrations	1-3
Abbreviations	1-3
Right and Left Identification	1-3
Catalog Revisions and Supplements	1-3
Parts Orders.....	1-3
2 TRANSITION	2-1
Drive Components	2-2
Slip Clutch and Header Lift Cylinder Extensions	2-4
Transition Fasteners	2-7
3 CARRIAGE	3-1
4 Y-BRACE	4-1
5 DROP AXLE	5-1
6 LADDERS	6-1
7 ELECTRICAL COMPONENTS	7-1
Cables and Wires.....	7-3
8 HYDRAULIC COMPONENTS	8-1
Hydraulic Hoses for SN 1001-1035	8-3
Hydraulic Hoses for SN 1036 thru 1074	8-4
Hydraulic Hoses for SN 1075 and After	8-5
Hydraulic Adapters for SN 1001-1035	8-6
Hydraulic Adapters for SN 1036 and After	8-7
9 MISCELLANEOUS	9-1
Labels, Literature, and Hose Clamps.....	9-1
10 PART NUMBER INDEX	10-1

Model 2800 Hillco Leveling System

1 GENERAL INFORMATION

SERIAL NUMBER LOCATION

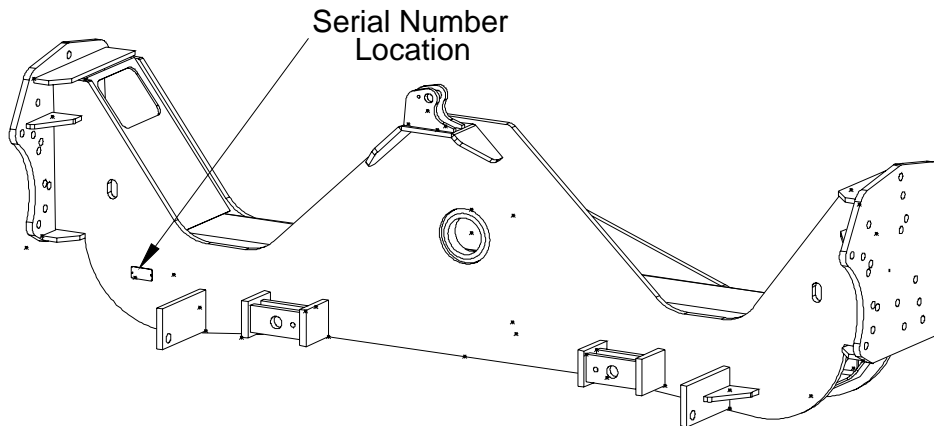

TEXT FORMAT AND ILLUSTRATIONS

The arrangement of this parts catalog is for easy identification of parts. All parts are illustrated in exploded views in proper relation to each other. Reference numbers used in the illustrations refer to line numbers in the part lists for each grouping. The part lists reference number, part number, part description and the quantity required per leveling system. Some part lists also include the page numbers of additional part breakdown information and reference the location of the part on the combine.

ABBREVIATIONS

SN "Serial Number" The four digits shown in the SN column refer to the last four digits in the Hillco serial number. Each Model 2800 system uses the following format: 2800-XXXX (sequential numbers).

ASM "Assembly" refers to a permanent grouping of parts not sold separately.

NSS "Not Sold Separately" refers to items depicted in illustrations that are not available to be purchased.

NS "Not Shown" refers to a part that is not depicted in the illustration.

RIGHT AND LEFT IDENTIFICATION

The reference to right-hand and left-hand in this catalog is identified by the operator standing at the rear of the machine looking toward the front of the machine (in normal forward travel).

CATALOG REVISIONS AND SUPPLEMENTS

Changes to the product may make it necessary to revise or add pages to this catalog. A cover sheet will list all pages released in a revision or supplement. All revised and new pages must be put into the parts catalog as soon as they are received.

PARTS ORDERS

Orders must specify product model, serial number, correct part number, complete description, quantity required, method of shipment, shipping address, and billing address.

Model 2800 Hillco Leveling System

2 TRANSITION

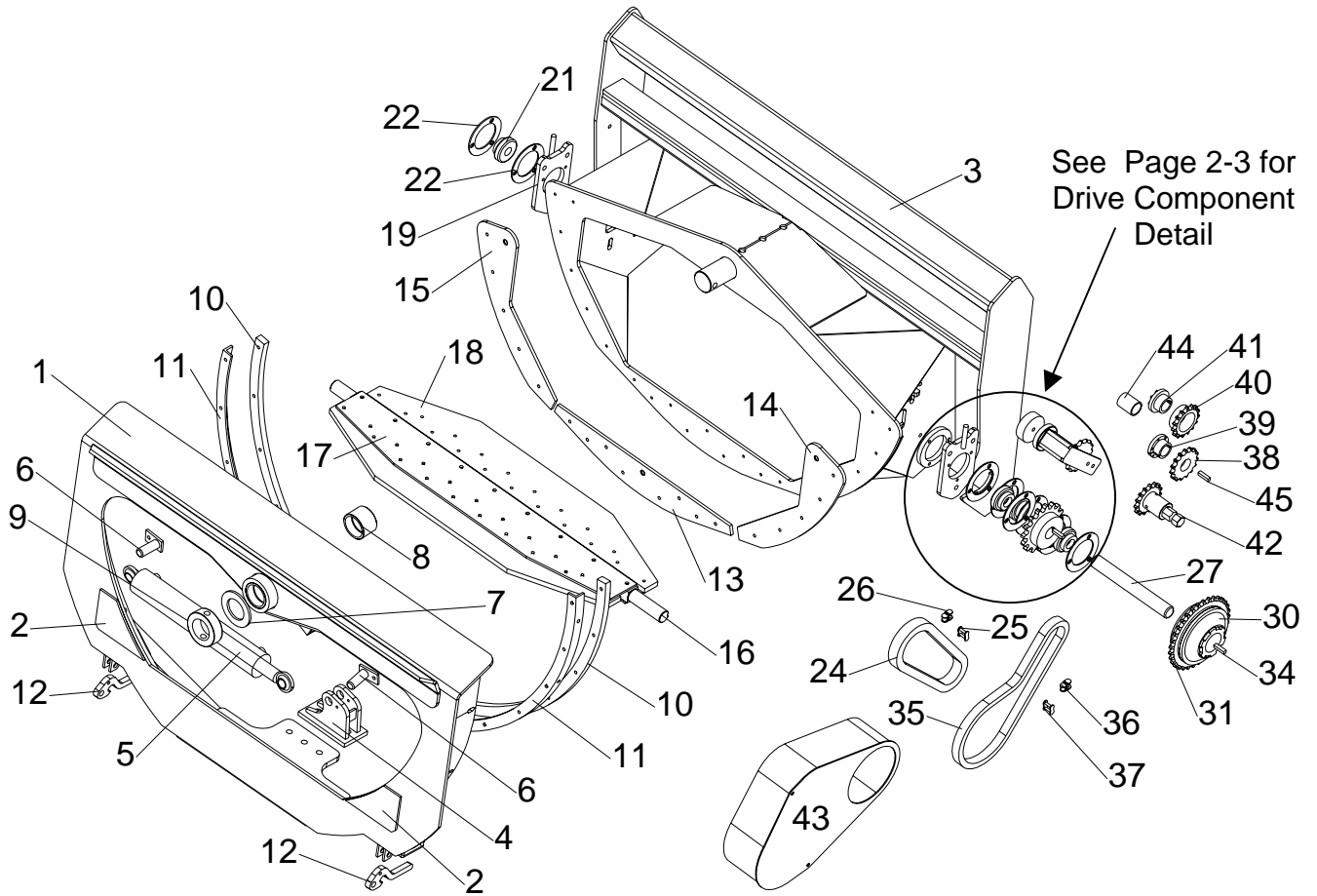

Model 2800 Hillco Leveling System

				TRANSITION	
REF.	PART NO.	SN	QTY.	PART NAME	DESCRIPTION
1	LA-227101	1010-	1	TA ASM	
	LA-225401	1001-1009	1	TA ASM	
2	LP-213301		2	OPTIONAL TA PLATE, WEAR	NORTHWEST
3	LA-226852	1078-	1	TT ASM	
	LA-226851	1010-1077	1	TT ASM	
	LA-225551	1001-1009	1	TT ASM	
4	LA-225411		1	TA MOUNT ASM, ROD	
5	HC-100706		1	CYLINDER, SLAVE	
6	LA-229071		2	TM PIN ASM, TRIM CYLINDER	
7	LM-218371		1	TT RING, WEAR	
NS	LM-212661	1001-1009	1	TT WASHER, PIVOT PIN	
8	LM-226831	1010-	1	TM BUSHING, PIVOT	
	LM-207801	1001-1009	1	THA BUSHING, PIVOT	REPLACED BY LM-226831
9	LM-226841	1010-	1	TM COLLAR, PIVOT	
NS	LM-213261	1001-1009	1	TT NUT, PIVOT HEX	
10	LM-225321		2	TA PAD, BACKING ANGLE WEAR	
11	LM-225311		2	TA ANGLE, BACKING	
12	LM-213291		2	TA ARM, HEADER LOCK	
13	LM-225522	1078-	1	TT PLATE, WEAR BOTTOM	
	LM-225521	1001-1077	1	TT PLATE, WEAR BOTTOM	
14	LM-225531		1	TT PLATE, WEAR LH	
15	LM-225541		1	TT PLATE, WEAR RH	
BEATER SHAFT					
16	LM-221601		1	TB SHAFT	
17	LM-213201		2	TB PLATE, PADDLE BACKING	NOT USED WITH METAL PADDLES
18	LP-104791		2	TB PADDLE (RUBBER)	REPLACED MC-100479
	LM-238091		2	TB PADDLE (METAL)	NOT SUITABLE FOR CORN
19	LA-212901	1001-1077	2	TB PLATE ASM, BEATER BRNG MNT	
20	LM-212701		1	TM KEY, BEATER DRIVE	
21	MC-100548		2	INSERT, BEARING, 1-7/16	
22	LA-243691	1078-	2	TM ASM, INNER FLANGETTE	
	MC-101339	1078-	2	FLANGETTE, RND BEARING	
	MC-101339	1001-1077	4	FLANGETTE, RND BEARING	
23	MC-135501	1078-	1	SPROCKET, 16T 80P	
	MC-135511	1078-	1	HUB, SPLIT TAPER 1-7/16	
	MC-101336	1001-1077	1	SPROCKET, 80P, 16 T, 1-7/16B, HD	
24	LM-213241	1001-1062, 1078-	1	TM CHAIN, 30 PIN #80	
	LM-23-2161	1063-1077	1	TM CHAIN, 28 PIN #80	
25	MC-101333		1	LINK, CONNECTING, 80P	
26	MC-101332		1	LINK, HALF, 80P	
TRANSITION THROAT JACK SHAFT					
27	LM-221591		1	BEFORE JJCO268800 TT SHAFT, JACK	
	LM-234151	1010-1085	1	JJCO268800 AND AFTER TT SHAFT, JACK	
	LM-234152	1086-	1	TT SHAFT, JACK (ALL COMBINES)	
28	MC-100548		2	INSERT, BEARING, 1-7/16	
29	MC-101339	1078-	3	FLANGETTE, RND BEARING	
	LA-243691	1078-	1	TM ASM, INNER FLANGETTE	
	MC-101339	1001-1077	4	FLANGETTE, RND BEARING	
30	LA-242431	1078-	1	SLIP CLUTCH ASM, RADIAL PIN	SEE PG. 2-5 FOR DETAILS
	MC-102153	1001-1077	1	CLUTCH, SLIP, 60P, 1-7/16B	SEE PG. 2-5 FOR DETAILS
31	LM-226532	1078-	1	TM SPROCKET, RADIAL SLIP CLUTCH	
	LM-226531	1001-1077	1	TM SPROCKET, PLATE, 33T 60P	
32	LM-243541	1078-	1	TM KEY, RADIAL PIN SLIP CLUTCH	
	LM-234231	1001-1077	1	TM KEY, TORQUE TAMER	
33	MC-135491	1078-	1	SPROCKET, 11T 80P	
	MC-135511	1078-	1	HUB, SPLIT TAPER 1-7/16	
	MC-102152	1001-1077	1	SPROCKET, 80P, 12T, 1-7/16B, HD	
34	LM-212701		1	TM KEY, BEATER DRIVE	
35	LM-213251		1	TM CHAIN, 62 PIN #60	
36	MC-100240		1	LINK, HALF, 60P	
37	MC-100239		1	LINK, CONNECTING, 60P	
FEEDER HOUSE BEATER DRIVE					
38	MC-100760		1	BEFORE JJCO193725 SPROCKET, QD, 60P, 15T	
39	MC-100762		1	BEFORE JJCO193725 HUB, QD, 1-1/2B	
40	LM-219801		1	JJCO193725-JJCO268800 TM SPROCKET, POWERLOCK, 15T 60P	
41	MC-101838		1	JJCO193725-JJCO268800 HUB, POWER LOCK, 1-3/8B	
42	LA-234251	1010-	1	JJCO268800 AND AFTER TM DRIVE ASM, TRANSITION	
43	LA-243871	1078-	1	BEFORE JJCO268800 (EXCEPT 1680) TM SHIELD ASM, BEATER DRIVE	
	LA-243811	1078-	1	JJCO268800 AND AFTER TM SHIELD ASM, BEATER DRIVE	
	LA-217741	1001-1077	1	BEFORE JJCO268800 TM SHIELD ASM, BEATER DRIVE	
	LA-234191	1001-1077	1	JJCO268800 AND AFTER TM SHIELD ASM, BEATER DRIVE	
44	LM-207011		1	BEFORE JJCO268800 TM SPACER, DRIVE SPROCKET	
45	LM-234221		1	BEFORE JJCO193725 TM KEY, FEEDER SHAFT	
TENSIONER					
46	MC-100546	1001-1077	1	TENSIONER	
47	MC-100237		1	SPROCKET, IDLER, 60P, 15T, 5/8B	
48	LM-234161	1001-1077	1	JJCO268800 AND AFTER TM SPACER, TENSIONER	
49	MC-137441	1078-	1	SPROCKET, IDLER 80P, 12T, 3/4B	
50	LM-243792	1078-	1	JJCO268800 AND AFTER (EXCEPT 1680) TM BRACKET, 60P IDLER	
	LM-243801	1078-	1	BEFORE JJCO268800 TM BRACKET, 60P IDLER	

Model 2800 Hillco Leveling System

DRIVE COMPONENTS

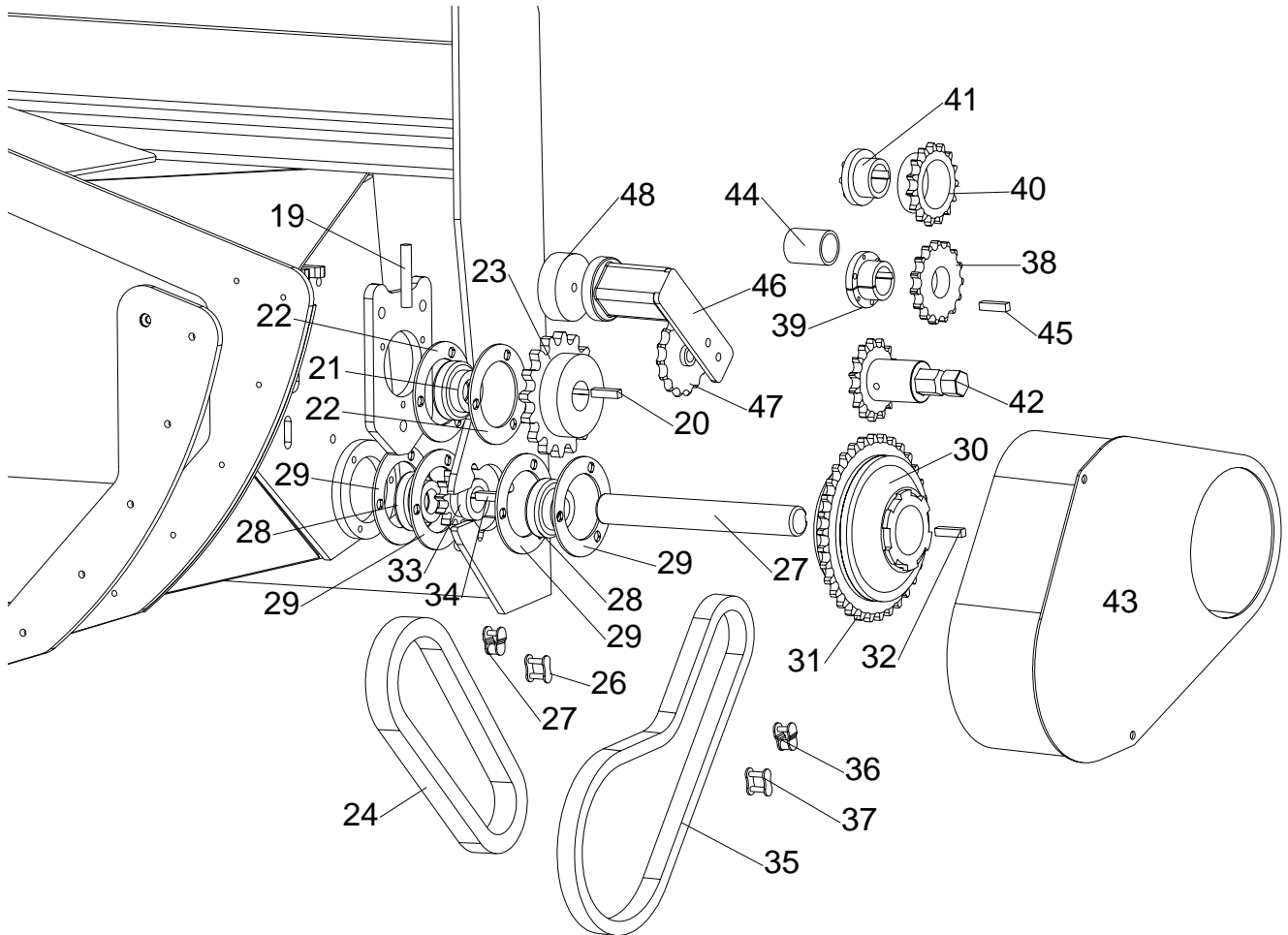

49 AND 50
NOT SHOWN IN
ILLUSTRATION

Model 2800 Hillco Leveling System

DRIVE COMPONENTS					
REF.	PART NO.	SN	QTY.	PART NAME	DESCRIPTION
BEATER SHAFT					
16	LM-221601		1	TB SHAFT	
17	LM-213201		2	TB PLATE, PADDLE BACKING	NOT USED WITH METAL PADDLES
18	LP-104791		2	TB PADDLE (RUBBER)	REPLACED MC-100479
	LM-238091		2	TB PADDLE (METAL)	NOT SUITABLE FOR CORN
19	LA-212901	1001-1077	2	TB PLATE ASM, BEATER BRNG MNT	
20	LM-212701		1	TM KEY, BEATER DRIVE	
21	MC-100548		2	INSERT, BEARING, 1-7/16	
22	LA-243691	1078-	2	TM ASM, INNER FLANGETTE	
	MC-101339	1078-	2	FLANGETTE, RND BEARING	
	MC-101339	1001-1077	4	FLANGETTE, RND BEARING	
23	MC-135501	1078-	1	SPROCKET, 16T 80P	
	MC-135511	1078-	1	HUB, SPLIT TAPER 1-7/16	
	MC-101336	1001-1077	1	SPROCKET, 80P, 16 T, 1-7/16B, HD	
24	LM-213241	1001-1062, 1078-	1	TM CHAIN, 30 PIN #80	
	LM-23-2161	1063-1077	1	TM CHAIN, 28 PIN #80	
25	MC-101333		1	LINK, CONNECTING, 80P	
26	MC-101332		1	LINK, HALF, 80P	
TRANSITION THROAT JACK SHAFT					
27	LM-221591		1	<i>BEFORE JJCO268800</i> TT SHAFT, JACK	
	LM-234151	1010-1085	1	<i>JJCO268800 AND AFTER</i> TT SHAFT, JACK	
	LM-234152	1086-	1	TT SHAFT, JACK (ALL COMBINES)	
28	MC-100548		2	INSERT, BEARING, 1-7/16	
29	MC-101339	1078-	3	FLANGETTE, RND BEARING	
	LA-243691	1078-	1	TM ASM, INNER FLANGETTE	
	MC-101339	1001-1077	4	FLANGETTE, RND BEARING	
30	LA-242431	1078-	1	SLIP CLUTCH ASM, RADIAL PIN	SEE PG. 2-5 FOR DETAILS
	MC-102153	1001-1077	1	CLUTCH, SLIP, 60P, 1-7/16B	SEE PG. 2-5 FOR DETAILS
31	LM-226532	1078-	1	TM SPROCKET, RADIAL SLIP CLUTCH	
	LM-226531	1001-1077	1	TM SPROCKET, PLATE, 33T 60P	
32	LM-243541	1078-	1	TM KEY, RADIAL PIN SLIP CLUTCH	
	LM-234231	1001-1077	1	TM KEY, TORQUE TAMER	
33	MC-135491	1078-	1	SPROCKET, 11T 80P	
	MC-135511	1078-	1	HUB, SPLIT TAPER 1-7/16	
	MC-102152	1001-1077	1	SPROCKET, 80P, 12T, 1-7/16B, HD	
34	LM-212701		1	TM KEY, BEATER DRIVE	
35	LM-213251		1	TM CHAIN, 62 PIN #60	
36	MC-100240		1	LINK, HALF, 60P	
37	MC-100239		1	LINK, CONNECTING, 60P	
FEEDER HOUSE BEATER DRIVE					
38	MC-100760		1	<i>BEFORE JJCO193725</i> SPROCKET, QD, 60P, 15T	
39	MC-100762		1	<i>BEFORE JJCO193725</i> HUB, QD, 1-1/2B	
40	LM-219801		1	<i>JJCO193725-JJCO268800</i> TM SPROCKET, POWERLOCK, 15T 60P	
41	MC-101838		1	<i>JJCO193725-JJCO268800</i> HUB, POWER LOCK, 1-3/8B	
42	LA-234251	1010-	1	<i>JJCO268800 AND AFTER</i> TM DRIVE ASM, TRANSITION	
43	LA-243871	1078-	1	<i>BEFORE JJCO268800 (EXCEPT 1680)</i> TM SHIELD ASM, BEATER DRIVE	
	LA-243811	1078-	1	<i>JJCO268800 AND AFTER</i> TM SHIELD ASM, BEATER DRIVE	
	LA-217741	1001-1077	1	<i>BEFORE JJCO268800</i> TM SHIELD ASM, BEATER DRIVE	
	LA-234191	1001-1077	1	<i>JJCO268800 AND AFTER</i> TM SHIELD ASM, BEATER DRIVE	
44	LM-207011		1	<i>BEFORE JJCO268800</i> TM SPACER, DRIVE SPROCKET	
45	LM-234221		1	<i>BEFORE JJCO193725</i> TM KEY, FEEDER SHAFT	
TENSIONER					
46	MC-100546	1001-1077	1	TENSIONER	
47	MC-100237		1	SPROCKET, IDLER, 60P, 15T, 5/8B	
48	LM-234161	1001-1077	1	<i>JJCO268800 AND AFTER</i> TM SPACER, TENSIONER	
49	MC-137441	1078-	1	SPROCKET, IDLER 80P, 12T, 3/4B	
50	LM-243792	1078-	1	<i>JJCO268800 AND AFTER (EXCEPT 1680)</i> TM BRACKET, 60P IDLER	
	LM-243801	1078-	1	<i>BEFORE JJCO268800</i> TM BRACKET, 60P IDLER	

Model 2800 Hillco Leveling System

FRICTION STYLE SLIP CLUTCH ASM					
REF.	PART NO.	SN	QTY.	PART NAME	DESCRIPTION
	MC-102153	1001-1077	1	CLUTCH, SLIP, 60P, 1-7/16B	WITHOUT SPROCKET AND BUSHING
1	NSS	1001-1077	1	HUB, 1-7/16B	
2	MC-100321	1001-1077	1	SPRING, BELVILLE	
3	MC-100322	1001-1077	2	PLATE, BACK UP	
4	MC-100323	1001-1077	1	DISK, FRICTION PAIR	
5	MC-100325	1001-1077	1	BUSHING, SINTERED, 3/8	
6	LM-226531	1001-1077	1	TM SPROCKET, PLATE, 33T 60P	
7	MC-100324	1001-1077	1	NUT, TENSIONING	

HEADER LIFT CYLINDER EXTENSIONS					
63 IN. FEEDER HOUSE OPTION					
REF.	PART NO.	SN	QTY.	PART NAME	DESCRIPTION
8	LA-220631		1	LM EXTENSION ASM, LIFT CYLINDER INNER LH	
9	LA-220661		1	LM EXTENSION ASM, LIFT CYLINDER INNER RH	
10	LA-220641		1	LM EXTENSION ASM, LIFT CYLINDER OUTER LH	
11	LA-220651		1	LM EXTENSION ASM, LIFT CYLINDER OUTER RH	
12	LM-218501		2	LM PIN, HEADER LIFT CYLINDER ROD MOUNT	
13	LM-226961	1010-	2	LM SPACER, HEADER LIFT CYLINDER	
54 IN. FEEDER HOUSE WITHOUT ROCK TRAP OPTION (DOES NOT INCLUDE NORTHWEST UNITS)					
10	LA-220641		2	LM EXTENSION ASM, LIFT CYLINDER OUTER LH	
11	LA-220651		2	LM EXTENSION ASM, LIFT CYLINDER OUTER RH	
12	LM-218501		2	LM PIN, HEADER LIFT CYLINDER ROD MOUNT	
13	LM-226961		2	LM SPACER, HEADER LIFT CYLINDER	2 HEADER LIFT CYL
13	LM-226961		4	LM SPACER, HEADER LIFT CYLINDER	3 HEADER LIFT CYL
54 IN. FEEDER HOUSE WITHOUT ROCK TRAP FASTENERS					
A	F-PCT-05X48		4	COTTER PIN 5/16 x 3	HEADER LIFT CYL ROD MNT
B	F-HC8-20C36		4	HC8 1-1/4-7 x 2-1/4	HEADER LIFT EXTENSION
B	F-HC8-20C		4	HN8 1-1/4-7	HEADER LIFT EXTENSION
B	F-LW-20A		4	LW 1-1/4 HD	HEADER LIFT EXTENSION
C	F-HC5-08C104		2	HC5 1/2-13 X 6-1/2	HEADER LIFT EXTENSION
C	F-HNS-08C		2	HN 1/2-13, STOVER LOCK	HEADER LIFT EXTENSION

TRANSITION FASTENERS

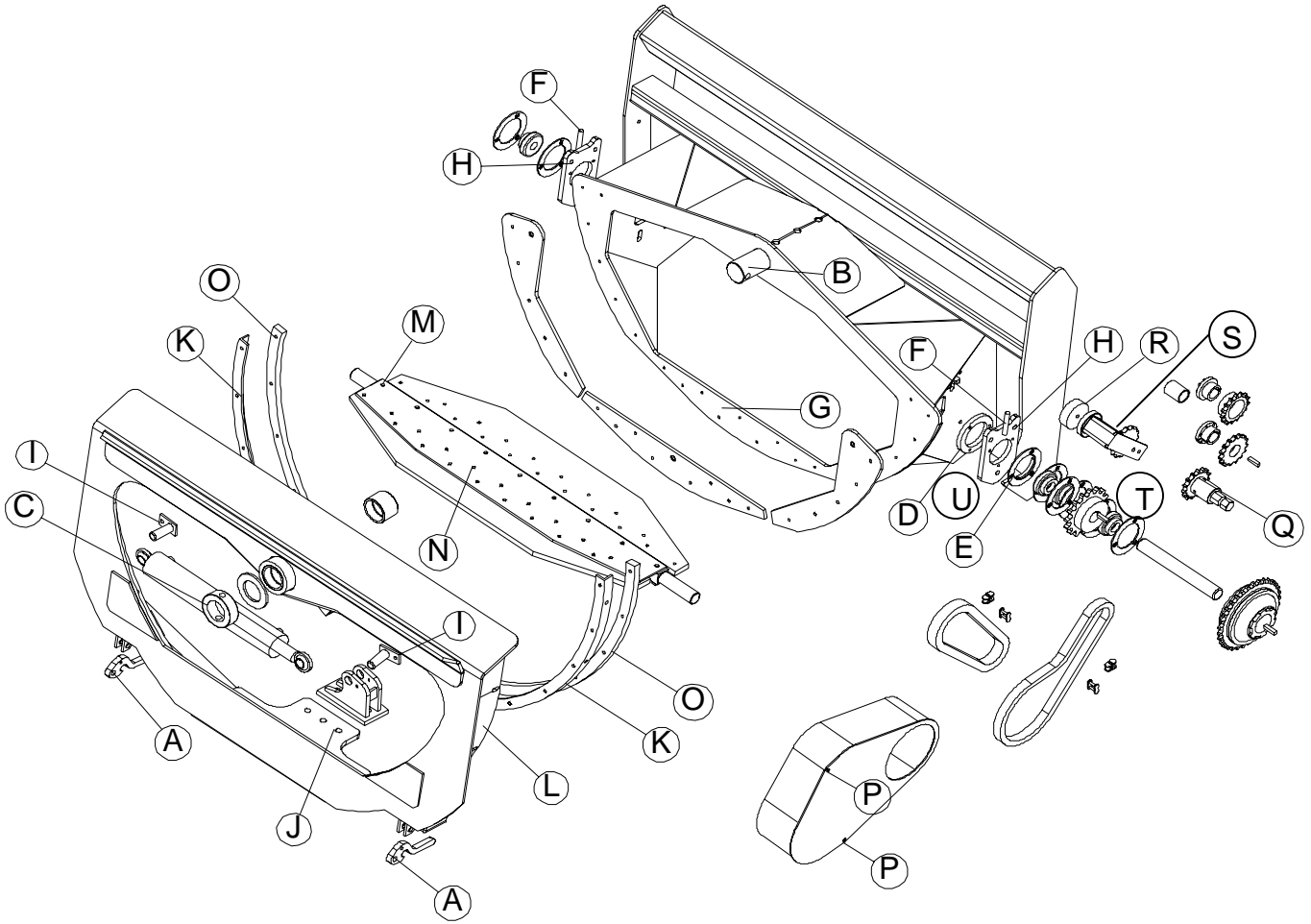

Model 2800 Hillco Leveling System

TRANSITION FASTENERS					
REF.	PART NO.	SN	QTY.	PART NAME	WHERE USED
A	F-PCL-10X24		2	PIN, CLEVIS, 5/8 x 1-1/2	HEADER LOCK ARM
A	F-PCT-02X16		2	PIN, COTTER, 1/8 x 1	HEADER LOCK ARM
B	F-MB-14NR40	1010-	3	BUSHING, MACH 14 GA, NR, 2-1/2 ID	TT PIVOT PIN
B	F-HNJ-40	1001-1009	1	HN 2-1/2-12 JAM	TT PIVOT PIN
B	F-PZS-02		1	PIPE ZERK, 1/8 NPT	TT PIVOT PIN
C	F-HC8-10C80	1010-	1	HC8 5/8-11 x 5	TT PIVOT PIN COLLAR
C	F-SS-06C08	1001-1009	1	SCREW, SET, 3/8-16 x 1/2	TT PIVOT PIN COLLAR
C	F-HNS-10C	1010-	1	HN8 5/8-11, STOVER	TT PIVOT PIN COLLAR
D	F-CB-06C20	1078-	3	BOLT, CARRIAGE 3/8-16 X 1-1/4	INNER 3 BOLT JACKSHAFT BEARING
D	F-HN5-06C	1078-	3	HN5, 3/8-16	INNER 3 BOLT JACKSHAFT BEARING
D	F-HC5-06C12	1001-1077	3	HC5 3/8-16 x 3/4	INNER 3 BOLT JACKSHAFT BEARING
D	F-LW-06		3	LW 3/8	INNER 3 BOLT JACKSHAFT BEARING
E	F-CB-06C20		3	BOLT, CARRIAGE, 3/8-16 x 1-1/4	OUTER 3 BOLT JACKSHAFT BEARING
E	F-HN5-06C		3	HN5 3/8-16	OUTER 3 BOLT JACKSHAFT BEARING
E	F-LW-06		3	LW 3/8	OUTER 3 BOLT JACKSHAFT BEARING
F	F-HNJ-08C	1001-1077	4	HN5 1/2-13 JAM	BEATER BRNG TAKE-UP BLT
F	F-FWH-08	1001-1077	4	FW 1/2 HD	BEATER BRNG TAKE-UP BLT
G	F-FHS-05F10		21	FHSC 5/16-24 x 5/8	TT FACE PLATE
H	F-CB-06C20	1078-	6	BOLT, CARRIAGE 3/8-16 X 1-1/4	TT BEATER BEARINGS
H	F-HN5-06C	1078-	6	HN5 3/8-16	TT BEATER BEARINGS
H	F-CB-08C28	1001-1077	6	BOLT, CARRIAGE, 1/2-13 X 1-3/4	TT BEATER BRNG MNT PLT
H	F-HN5-08C	1001-1077	6	HN5 1/2-13	TT BEATER BRNG MNT PLT
H	F-LW-08	1001-1077	6	LW 1/2	TT BEATER BRNG MNT PLT
H	F-HC5-06C14	1001-1009	6	HC5 3/8-16 x 7/8	TT BEATER BRNG MNT PLT
H	F-HC5-06C12	1010-1077	6	HC5 3/8-16 x 3/4	TT BEATER BRNG MNT PLT
H	F-LW-06		6	LW 3/8	TT BEATER BRNG MNT PLT
I	F-HC5-06C12		2	HC5 3/8-16 x 3/4	SLAVE CYL MNT PIN
I	F-LW-06		2	LW 3/8	SLAVE CYL MNT PIN
J	F-HC8-10C32		3	HC8 5/8-11 x 2	ROD MNT
J	F-HN8-10C	1001-1035	3	HN8 5/8-11	ROD MNT
J	F-LW-10A	1001-1035	3	LW HD 5/8	ROD MNT
J	F-HNS-10C	1036-	3	HN8 5/8-11 STOVER FLNG	ROD MNT
K	F-HC5-06C20		8	HC5 3/8-16 x 1-1/4	BACKING ANGLE
K	F-HN5-06C		8	HN5 3/8-16	BACKING ANGLE
K	F-LW-06		8	LW 3/8	BACKING ANGLE
K	F-FWH-06		8	FW HD 3/8	BACKING ANGLE
L	F-HC5-08C32		2	HC5 1/2-13 x 2	TRANSITION MNT
L	F-HN5-08C		2	HN5 1/2-13	TRANSITION MNT
L	F-LW-08		2	LW 1/2	TRANSITION MNT
M	F-HC8-08C44	1078-	9	HC8 1/2-13 X 2-3/4	BEATER BACKING PLT MNT
M	F-HNSF-08C	1078-	9	HN 1/2-13 STOVER, FLNG.	BEATER BACKING PLT MNT
M	F-HC8-06C40	1001-1077	9	HC8 3/8-16 x 2-1/2	BEATER BACKING PLT MNT
M	F-HN8-06C	1001-1016	9	HN8 3/8-16	BEATER BACKING PLT MNT
M	F-HNS-06C	1017-1077	9	HN8 3/8-16, STOVER FLNG	BEATER BACKING PLT MNT
M	F-LW-06A	1001-1016	9	LW 3/8 HD	BEATER BACKING PLT MNT
N	F-EB-04C20		38	BOLT, ELEVATOR, 1/4-20 x 1-1/4	PADDLE MNT (RUBBER PADDLES ONLY)
N	F-HNF-04C		38	HN 1/4-2 FLNG, SERR	PADDLE MNT (RUBBER PADDLES ONLY)
O	F-FHS-05F20		16	FHSC 5/16-24 x 1-1/4	UHMW BACKING WEAR PAD
O	F-HNS-05F		16	HN 5/16-24, STOVER	UHMW BACKING WEAR PAD
NS	F-THM-06C16		2	THMS 3/8-16 x 1	HEADER HYDRAULIC COUPLER MOUNT
NS	F-HNF-06C		2	HN 3/8-16, FLNG, SERR	HEADER HYDRAULIC COUPLER MOUNT
P	F-THM-05C16	1078-	2	THMS 5/16-18 X 1	BEATER DRIVE SHIELD (ALL COMBINES)
P	F-HNF-05C	1078-	2	HN 5/16-18, FLNG., SERR	BEATER DRIVE SHIELD (ALL COMBINES)
P	F-THM-04C08	1078-	4	THMS 1/4-20 X 1/2, SERR.	BEATER DRIVE SHIELD SKIRT (ALL COMBINES)
P	F-HNF-04C	1078-	4	HN 1/4-20, FLNG, SERR	BEATER DRIVE SHIELD SKIRT (ALL COMBINES)
P	F-HC5-06C136	1001-1077	2	HC5 3/8-16 X 8-1/2	BEATER DRIVE SHIELD (JJCO268800 AND AFTER)
P	F-THM-06C96	1001-1077	2	THMS 3/8-16 x 6	BEATER DRIVE SHIELD (BEFORE JJCO268800)
P	F-HNF-06C	1001-1077	2	HN 3/8-16, FLNG, SERR	BEATER DRIVE SHIELD (ALL COMBINES)
Q	F-SSS-06C08		2	SOCKET HEAD SET SCREW 3/8-16 X 1/2 GR 8	TRANSITION DRIVE ASM
R	F-HC-12M065E	1001-1077	1	JJCO268800 AND AFTER HC 10.9 - 12 X 1.75 X 65	ROSTA TENSIONER SPACER
S	LA-242951	1001-1077	1	BOLT KIT, ROSTA TENSIONER	ROSTA TENSIONER
T	F-HC5-08C20	1078-	2	HC5 1/2-13 X 1-1/4	60P IDLER SPROCKET BRACKET (ALL)
T	F-LW-08	1078-	2	LW 1/2	60P IDLER SPROCKET BRACKET (ALL)
T	F-HN5-08C	1078-	2	HN5 1/2-13	60P IDLER SPROCKET BRACKET (ALL)
T	F-CB-10C40	1078-	1	BOLT, CARRIAGE 5/8-11 X 2-1/2	60P IDLER SPROCKET
T	F-HNN-10C	1078-	1	HN 5/8-11, NYLOCK	60P IDLER SPROCKET
T	F-FWH-10	1078-	1	FW 5/8 HD	60P IDLER SPROCKET
U	LM-248981	1078-	1	TM BOLT, 80P IDLER	80P IDLER SPROCKET
U	F-HNN-12C	1078-	1	HN 3/4-10, NYLOCK	80P IDLER SPROCKET
U	F-FWH-12	1078-	5	FW 3/4 HD	80P IDLER SPROCKET

Model 2800 Hillco Leveling System

3 CARRIAGE

FRONT VIEW

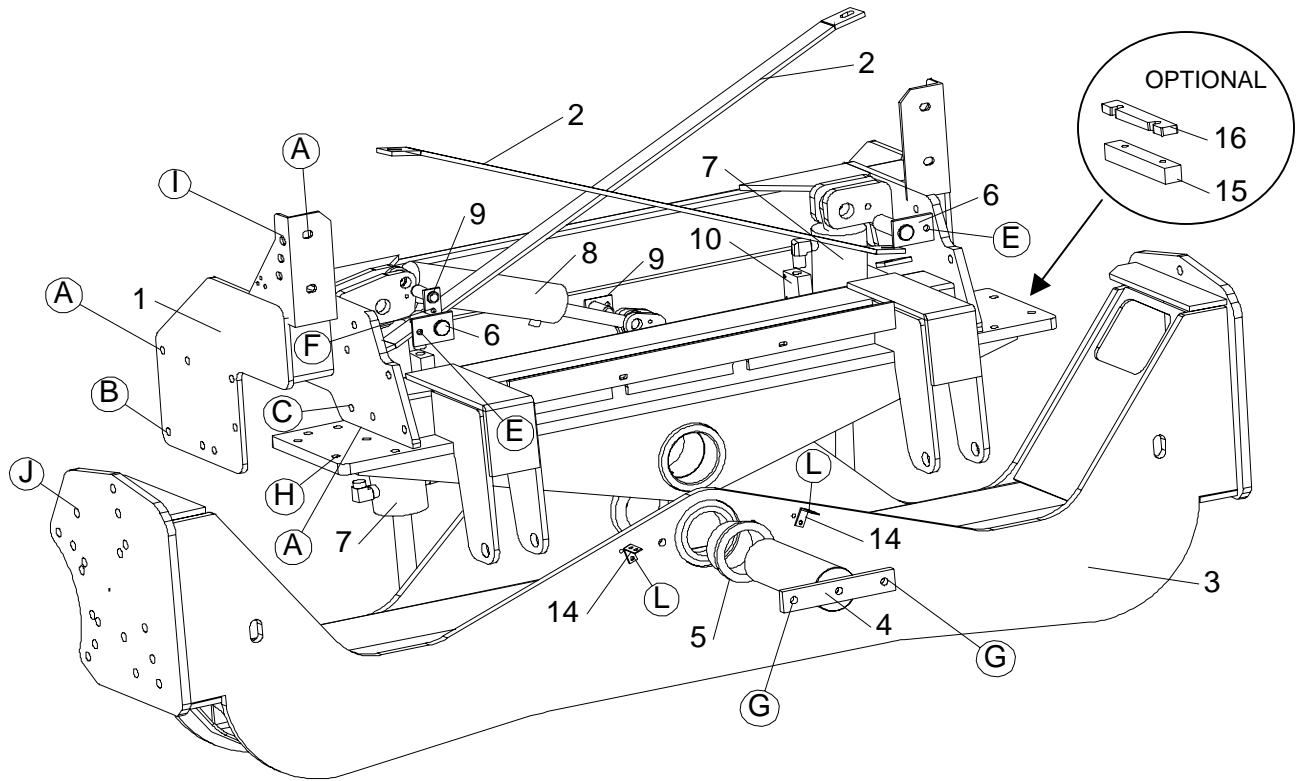

REAR VIEW

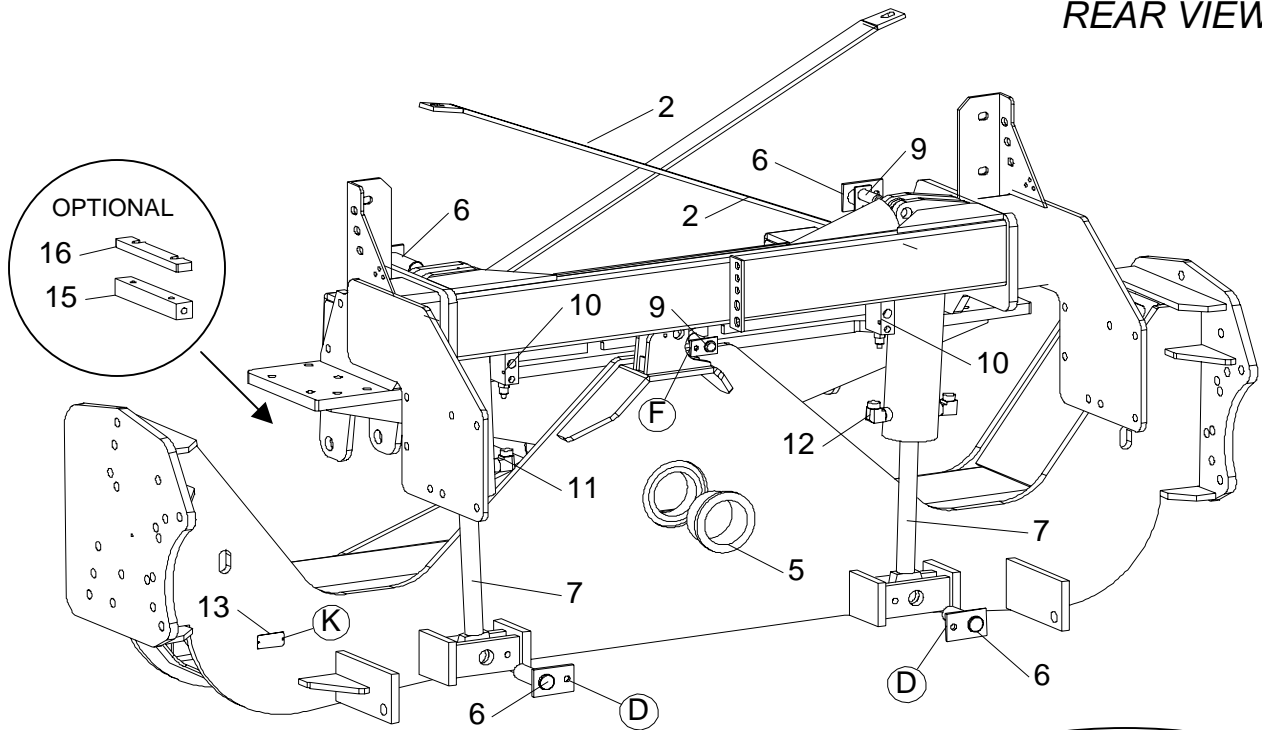

17 AND 18
NOT SHOWN IN
ILLUSTRATION

Model 2800 Hillco Leveling System

CARRIAGE					
REF.	PART NO.	SN	QTY.	PART NAME	DESCRIPTION
1	LA-227242	1010-	1	CO OVERCARRIAGE ASM	2 LIFT CYLINDER
NS	LA-227252	1010-	1	CO OVERCARRIAGE ASM	3 LIFT CYLINDER
	LA-225951	1001-1009	1	CO OVERCARRIAGE ASM	
NS	LM-235481		1	OPTIONAL CM PIN, THIRD LIFT CYLINDER	3 LIFT CYLINDER
2	LM-226631		2	CO STRAP, X BRACE	
3	LA-227261	1002-	1	CU UNDERCARRIAGE ASM	
	LA-225751	1001	1	CU UNDERCARRIAGE ASM	
4	LA-217691		1	CM PIN ASM, MAIN PIVOT	
5	LP-103871		2	CO BUSHING, PIVOT	
6	LA-230551		4	CM PIN ASM, MAIN CYLINDER	
7	HC-103227		2	CYLINDER, MAIN 2800	
8	HC-101842		1	CYLINDER, MASTER	
9	LA-229071		2	TM PIN ASM, TRIM CYLINDER	
10	HC-101265		2	VALVE, COUNTERBALANCE	
11	LM-206841		1	HM ADAPTER, 90 DEGREE WITH PILOT RIGHT	
12	LM-206851		1	HM ADAPTER, 90 DEGREE WITH PILOT LEFT	
13	LL20-100790		1	PLATE, SERIAL NUMBER	
14	LM-226111		2	EM MOUNT, LIMIT SWITCH STOP	
15	LM-227271	1036-1102	2	OPTIONAL CO BAR, LEVEL LIMIT	
16	LP-227281	1036-1102	1	OPTIONAL CO SPACER, LEVEL LIMIT (PAIR)	AS NEEDED
17	MC-137251	1103-	1	COLLAR, 2 PIECE CLAMPING	AS NEEDED
18	MC-137501	1103-	1	WASHER, QUICK REPAIR	AS NEEDED
NS	LA-241131	1010-	1	3RD HEADER LIFT CYLINDER BRACKET	OPTIONAL
CARRIAGE FASTENERS					
REF.	PART NO.	SN	QTY.	PART NAME	WHERE USED
A	F-LW-10A	1001-1009	25	LW HD 5/8	OVERCARRIAGE
A	F-HNS-10C	1001-1009	25	HN8 5/8-11	OVERCARRIAGE
A	F-HNS-10C	1010-	42	HN8 5/8-11 STOVER LOCK	OVERCARRIAGE
A	F-FWH-10	1010-	44	FW HD 5/8	OVERCARRIAGE
B	F-HC8-10C24		14	HC8 5/8-11 x 1-1/2	OC REAR SIDE PLT
C	F-HC8-10C24	1001-1009	1	HC8 5/8-11 x 1-1/2	OC FRONT SIDE PLT
C	F-HNJ-10C	1001-1009	1	HN 5/8-11 JAM	OC FRONT SIDE PLT
C	F-HC8-10C32	1001-1009	7	HC8 5/8-11 x 2	OC FRONT SIDE PLT
C	F-HC8-10C32	1010-	12	HC8 5/8-11 x 2	OC FRONT SIDE PLT
D	F-HC5-08C28		2	HC5 1/2-13 x 1-3/4	LOWER MAIN CYL MNT PIN
D	F-LW-08		2	LW 1/2	LOWER MAIN CYL MNT PIN
D	F-HN5-08C		2	HN5 1/2-13	LOWER MAIN CYL MNT PIN
E	F-LW-08		2	LW 1/2	TOP MAIN CYL MNT PIN
E	F-HN5-08C		2	HN5 1/2-13	TOP MAIN CYL MNT PIN
F	F-HC5-06C16		2	HC5 3/8-16 x 1	MASTER CYL MNT PIN
F	F-LW-06		2	LW 3/8	MASTER CYL MNT PIN
F	F-HN5-06C		2	HN5 3/8-16	MASTER CYL MNT PIN
G	F-HC8-10C36		2	HC8 5/8-11 X 2-1/4	MAIN PVT PIN
G	F-HNS-10C		2	HN8 5/8-11, STOVER	MAIN PVT PIN
G	F-HC5-10F16	1001-1025	1	HC5 5/8-18 X 1	MAIN PVT PIN
G	F-FW-10	1010-	2	FW 5/8	MAIN PVT PIN
H	F-HC8-10C36	1001-1009	6	HC8 5/8-11 x 2-1/4	OC BASE PLT
H	F-HC8-10C36	1010-	8	HC8 5/8-11 x 2-1/4	OC BASE PLT
I	F-HC8-10C32	1010-	10	HC8 5/8-11 x 2	OC UPPER FRAME SUPPORTS
J	F-SHC-20F65E	1041-	6	MM SHCS 10.9- 20 x 2.5 x 60	FINAL MOUNT
J	F-HC-20F65E	1041-	22	MM HC 10.9 - 20 x 2.5 x 60	FINAL MOUNT
J	F-LWH-20M		28	MM LW 20 HD	FINAL MOUNT
J	F-SHC-20F60E	1001-1040	4	MM SHCS 10.9- 20 x 2.5 x 65	FINAL MOUNT
J	F-HC-20F60E	1001-1040	24	MM HC 10.9 - 20 x 2.5 x 65	FINAL MOUNT
K	F-UDS-#7X06		2	SCREW, U-DRIVE # 7 x 3/8	SERIAL NUMBER PLT
L	F-EB-04C20		2	BOLT, ELEVATOR 1/4-20 X1-1/4	LIMIT SWITCH ACTUATOR
L	F-HNF-04C		4	HN 1/4-20, FLNG, SERR	LIMIT SWITCH ACTUATOR
L	F-TCH-06C12		2	THREAD CUTTER, HWH 3/8-16 x 3/4	LIMIT SWITCH ACTUATOR MNT

Model 2800 Hillco Leveling System

4 Y-BRACE

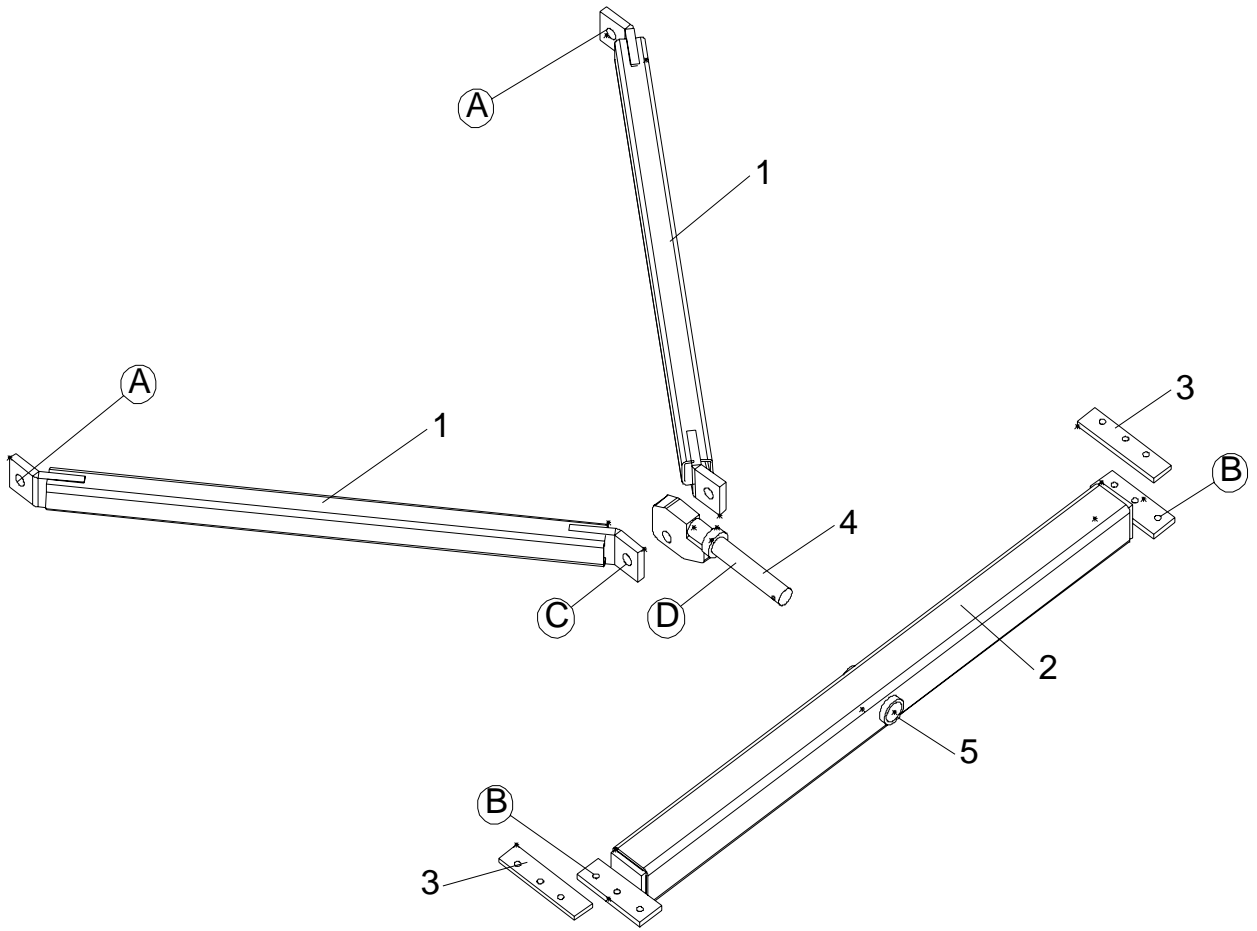

Model 2800 Hillco Leveling System

Y-BRACE					
REF.	PART NO.	SN	QTY.	PART NAME	DESCRIPTION
1	LA-226991		2	YB ARM ASM	
2	LA-226101		1	YB CROSS SUPPORT ASM	
3	LM-226061		2	YB CLAMP, CROSS SUPPORT	
4	LA-228761		1	YB PIN ASM, PIVOT	
5	LM-245431	1078-	2	YB BUSHING, PLANE	
	MC-100758	1001-1077	2	BUSHING, STEP	CAN BE REPLACED WITH LM-245431
Y-BRACE FASTENERS					
REF.	PART NO.	SN	QTY.	PART NAME	WHERE USED
A	F-HC8-16C44		2	HC8 1-8 x 2-3/4	Y-BRACE FRNT MNT
A	F-HNS-16C		2	HN8 1-8, STOVER	Y-BRACE FRNT MNT
B	F-HC8-08C36		6	HC8 1/2-13 x 2-1/4	Y-BRACE FRAME MNT
B	F-HNS-08C		6	HN8 1/2-13, STOVER	Y-BRACE FRAME MNT
C	F-HC8-16C72	1010-	1	HC8 1-8 x 4-1/2	Y-BRACE REAR MNT
C	F-HC8-16C56	1001-1009	1	HC8 1-8 x 3-1/2	Y-BRACE REAR MNT
C	F-HNS-16C		1	HN8 1-8, STOVER	Y-BRACE REAR MNT
D	F-HNC-24F	1001-1009	1	HN 1-1/2-12, CASTELLATED	Y-BRACE PVT PIN
D	F-PCT-05X48	1001-1009	1	PIN, COTTER, 5/16 x 3	Y-BRACE PVT PIN
D	F-HC8-08C48		1	HC8 1/2-13 x 3	Y-BRACE PVT PIN
D	F-HNS-08C		1	HN8 1/2-13, STOVER	Y-BRACE PVT PIN
D	F-MB-18NR24		10	BUSHING, MACH 18 GA NR 1-1/2 ID	Y-BRACE PVT PIN

5 DROP AXLE

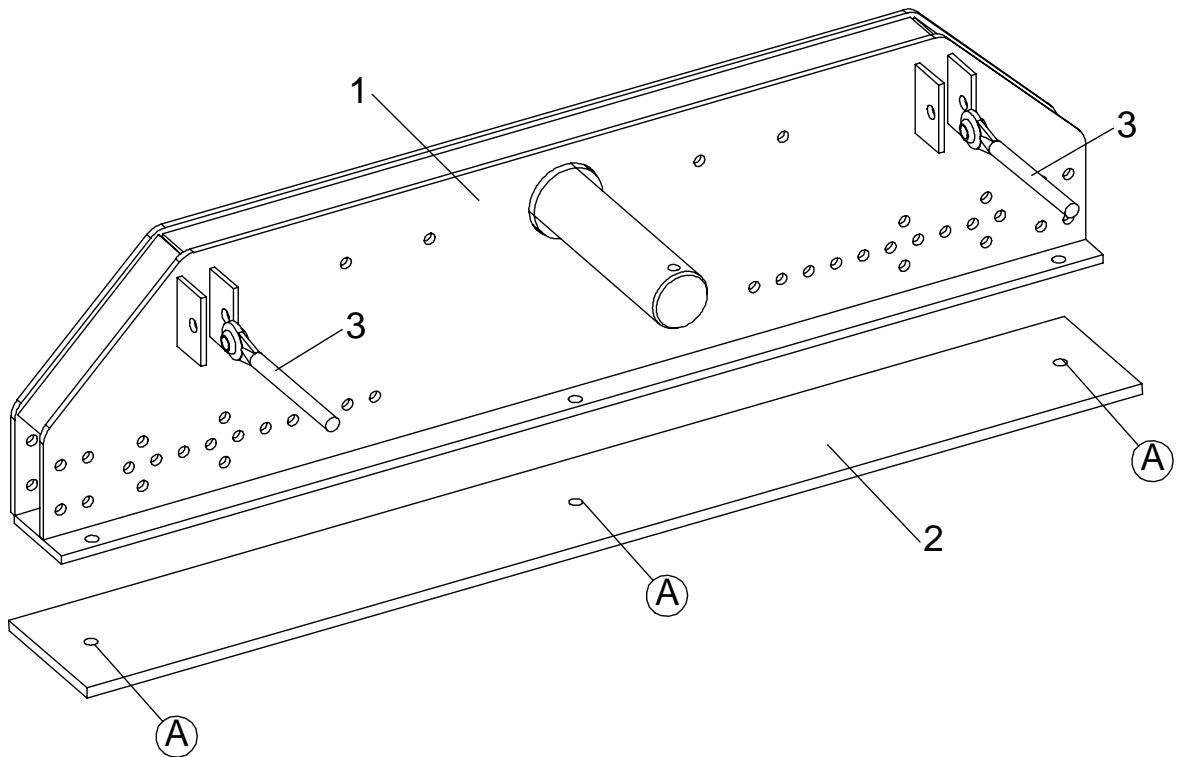

Model 2800 Hillco Leveling System

DROP AXLE					
REF.	PART NO.	SN	QTY.	PART NAME	DESCRIPTION
1	LA-226901		1	DA ASM	
2	LM-212561		1-13	DA WEIGHT, 160 LB.	
3	MC-133711	1026-	2	LINK, BALL JOINT DRAG	
NS	MC-100700	1001-1025	2	JOINT, BALL, 2.50 O.D. x .87 BORE	REPLACED BY MC-133711
DROP AXLE FASTENERS					
REF.	PART NO.	SN	QTY.	PART NAME	WHERE USED
NS	F-HC8-12C96		6	HC8 3/4-10 x 6	STEERING CYL MNT
A	F-HC8-12C56		3	HC8 3/4-10 x 3-1/2	1 WEIGHT BOLT PACKAGE
A	F-HC8-12C56		3	HC8 3/4-10 x 3-1/2	2 WEIGHT BOLT PACKAGE
A	F-HC8-12C72		3	HC8 3/4-10 x 4-1/2	3 WEIGHT BOLT PACKAGE
A	F-HC8-12C88		3	HC8 3/4-10 x 5-1/2	4 WEIGHT BOLT PACKAGE
A	F-HC8-12C96		3	HC8 3/4-10 x 6	5 WEIGHT BOLT PACKAGE
A	F-HC8-12C112		3	HC8 3/4-10 x 7	6 WEIGHT BOLT PACKAGE
A	F-HC8-12C120		3	HC8 3/4-10 x 7-1/2	7 WEIGHT BOLT PACKAGE
A	F-HC8-12C136		3	HC8 3/4-10 x 8-1/2	8 WEIGHT BOLT PACKAGE
A	F-HC8-12C144		3	HC8 3/4-10 x 9	9 WEIGHT BOLT PACKAGE
A	F-HC8-12C160		3	HC8 3/4-10 x 10	10 WEIGHT BOLT PACKAGE
A	F-HC8-12C168		3	HC8 3/4-10 x 10-1/2	11 WEIGHT BOLT PACKAGE
A	F-HC8-12C184		3	HC8 3/4-10 x 11-1/2	12 WEIGHT BOLT PACKAGE
A	F-HC8-12C192		3	HC8 3/4-10 x 12	13 WEIGHT BOLT PACKAGE
A	F-HN8-12C		3	HN8 3/4-10	ALL WEIGHT BOLT PACKAGE
A	F-LW-12A		3	LW 3/4 HD	ALL WEIGHT BOLT PACKAGE
A	F-FWH-12		3	FW 3/4 HD	ALL WEIGHT BOLT PACKAGE
NS	F-HC5-12C88		4	OPTIONAL HC5 3/4-10 X 5-1/2	4WD ASM MOUNT
NS	F-FW-12		4	OPTIONAL FW 3/4	4WD ASM MOUNT
NS	F-HNF-12C		4	OPTIONAL HN 3/4-10, FLNG., SERR.	4WD ASM MOUNT

6 LADDERS

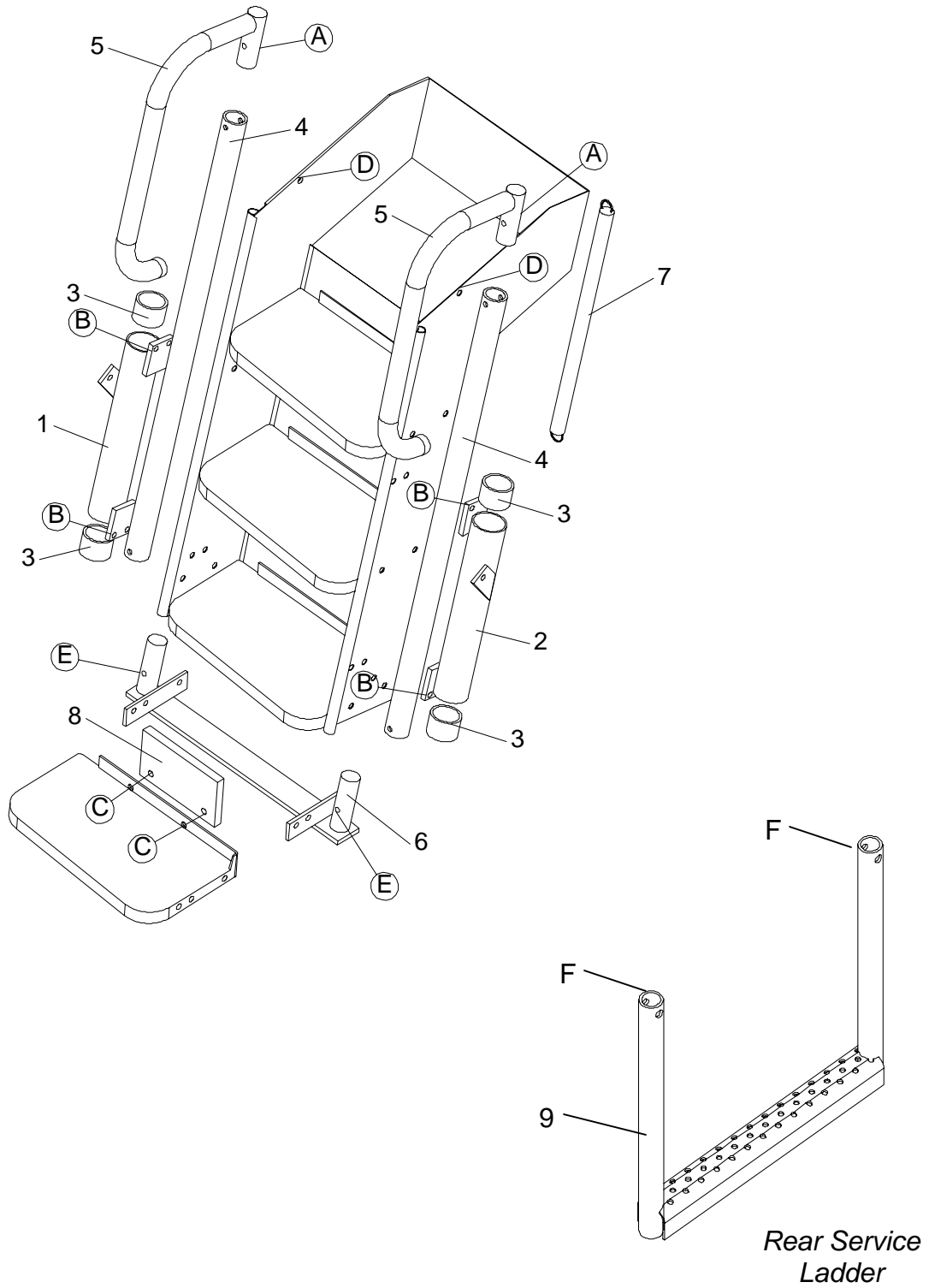

Model 2800 Hillco Leveling System

LADDERS					
REF.	PART NO.	SN	QTY.	PART NAME	DESCRIPTION
1	LA-214931		1	LM BUSHING ASM, SLIDE TUBE LH	
2	LA-219511		1	LM BUSHING ASM, SLIDE TUBE RH	
3	LM-214941		4	LM BUSHING, SLIDE	
4	LM-214951		2	LM TUBE, SLIDE	
5	LA-227001	1010-	2	LM HANDLE ASM, LADDER	
NS	LA-214981	1001-1009	2	LM HANDLE ASM, SLIDE TUBE	REPLACED BY LA-227001
6	LA-226971		1	LM STEP ASM, SLIDE 21-2300	
7	MC-100710		2	SPRING, EXTENSION, ZINC PLATED	
8	LP-117921		1	LM BUMPER, STEP	
9	LA-238131	1057-	1	LM STEP ASM, REAR SERVICE LDR	
LADDER FASTENERS					
REF.	PART NO.	SN	QTY.	PART NAME	WHERE USED
A	F-PR-06X40		2	PIN, ROLL, 3/8 x 2-1/2	SECURES HANDLE ASM TO SLIDE TUBE
B	F-THMS-06C16	1001-1009	10	THMS 3/8-16 x 1, SLT, SERR	SECURES TUBE ASM TO LADDER CHANNEL
B	F-THMS-06C16	1010-	16	THMS 3/8-16 x 1, SLT, SERR	SECURES TUBE ASM TO LADDER CHANNEL
C	F-THMS-06C24	1001-1009	2	THMS 3/8-16 x 1-1/2, SLT, SERR	BUMPER MNT
C	F-FW-06	1010-	2	FW 3/8	BUMPER MNT
D	F-PHMS-06C40		2	PHMS 3/8-16 x 2-1/2, SLT	TOP SPRING MNT
D	LM-230821		2	CHAIN, 2/0 STR. LINK, PLATED - 5 LINKS	TOP SPRING MNT
E	F-PHMS-06C56		2	PHMS 3/8-16 x 3-1/2, SLT	STEP AND BOTTOM SPRING MOUNT
E	F-HNF-06C	1001-1009	20	HN 3/8-16, FLNG, SERR	STEP AND BOTTOM SPRING MOUNT
E	F-HNF-06C	1010-	30	HN 3/8-16, FLNG, SERR	STEP AND BOTTOM SPRING MOUNT
E	LM-230811		2	CHAIN, 2/0 STR. LINK, PLATED - 1 LINK	BOTTOM SPRING MNT
F	F-PHMS-06C32	1057-	2	PHMS 3/8-16 X 2, SLT	RIGHT REAR SERVICE LADDER EXT STEP
F	F-HNF-06C	1057-	2	HN 3/8-16, FLNG SERR	RIGHT REAR SERVICE LADDER EXT STEP
NS	F-THMS-06C16	1057-	2	THMS 3/8-16 X 1, SLT SERR	RIGHT REAR SERVICE LADDER HANDLE
NS	F-HNF-06C	1057-	2	HN 3/8-16, FLNG SERR	RIGHT REAR SERVICE LADDER HANDLE

7 ELECTRICAL COMPONENTS

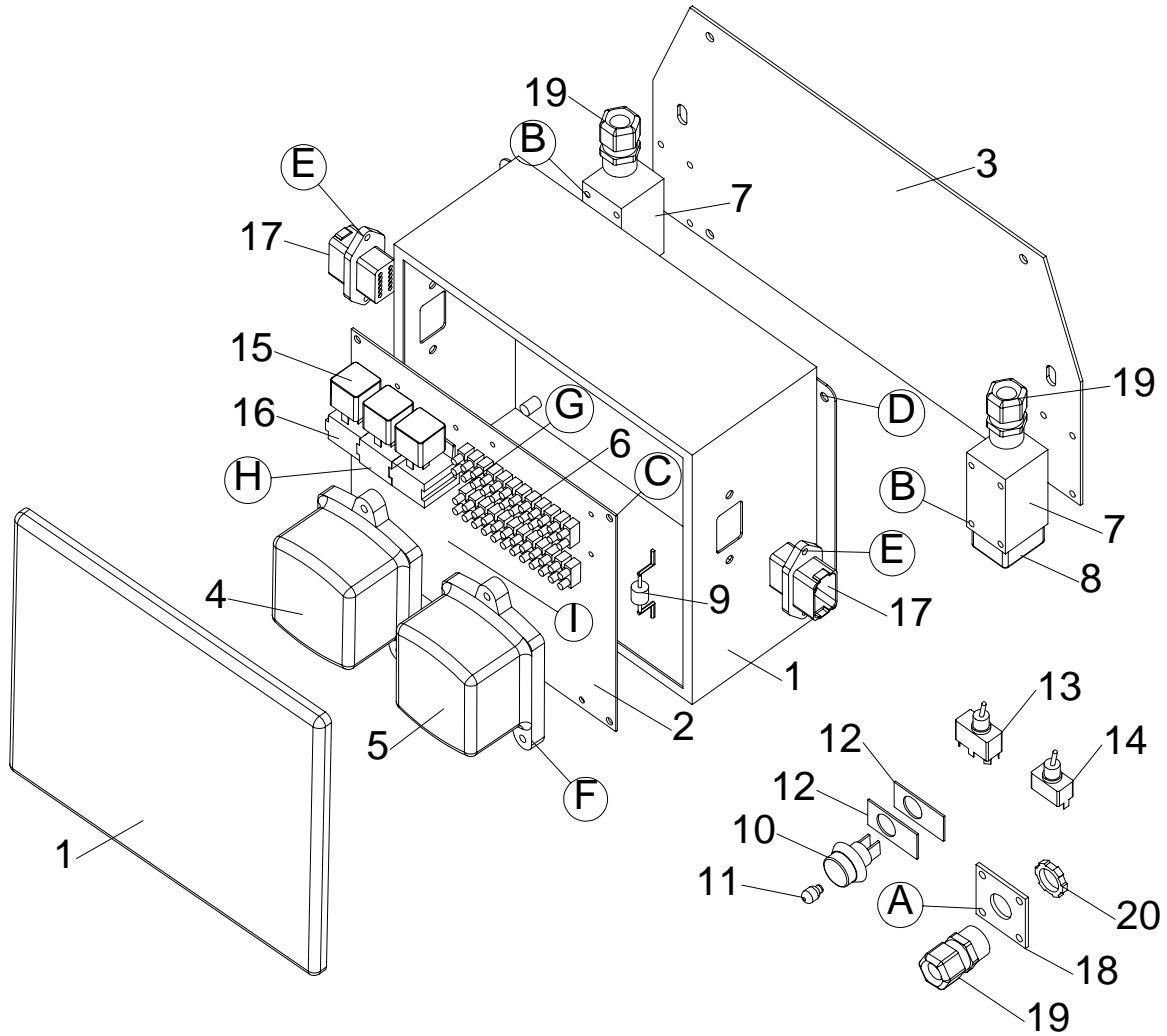

Model 2800 Hillco Leveling System

ELECTRICAL					
REF.	PART NO.	SN	QTY.	PART NAME	DESCRIPTION
1	LM-230501		1	EM BOX, CONTROL	
2	LM-229501		1	EM PLATE, CONTROLER MOUNT	
3	LM-229491		1	EM PLATE, CONTROL BOX MOUNT	
4	LA-206021		1	LOW SPEED LEVELING CONTROLLER ASM	
5	LA-206031		1	HIGH SPEED LEVELING CONTROLLER ASM	
6	EC-100012		2	STRIP, TERMINAL	
7	EC-100557		2	BODY, LIMIT SWITCH	
8	EC-100692		2	HEAD, LIMIT SWITCH STRAIGHT PLUNGER	
9	EC-133281		8	DIODE, 6 AMP, 50 PIV, SILICON	
10	EC-101876		1	LAMP, INDICATOR	
11	EC-101877		1	BULB, INDICATOR LAMP	
12	LM-219501		2	EM MOUNT, OUT OF LEVEL LAMP	
NS	LL20-101869		1	PLATE, MAXIMUM LEVEL	
13	EC-101874		1	SWITCH, TOGGLE, DP ON-OFF-ON, 3 POS.	
14	EC-100177		1	SWITCH, TOGGLE, SP MO-OFF-MO, 3 POS.	
NS	LL20-101868		1	PLATE, CONSOLE SWITCH	
15	EC-100010		3	RELAY, AUTOMOTIVE	
16	EC-100009		3	BASE, RELAY, AUTOMOTIVE	
17	EC-100555		2	RECEPTACE, 12 PIN MOUNT FLANGE	
NS	EC-100008		14	TERMINAL, RELAY, AUTOMOTIVE	
18	LM-207631		1	LM MOUNT, CAB STRAIN RELIEF	
19	EC-100186		3	STRAIN RELIEF, PLASTIC, 1/2	
20	EC-100187		1	NUT, SEALING LOCK	
NS	EC-100016		6	WIRE TIE, 1/8 X 4	
NS	EC-100018	1001-1016	10	WIRE TIE, HEAVY DUTY	
	EC-100018	1017-	16	WIRE TIE, HEAVY DUTY	
NS	LA-236731		1	AUTO CENTER DISABLE RELAY KIT	WITH FIELD TRACKER
NS	LA-235471		1	LATERAL TILT RELAY KIT	WITHOUT FIELD TRACKER
ELECTRICAL FASTENERS					
REF.	PART NO.	SN	QTY.	PART NAME	WHERE USED
A	F-TCH-#10C08		4	THREAD CUTTER, HWH 10-24 x 1/2	CAB STRAIN RELIEF MNT
B	F-PHM-#10C28		8	PHMS 10-24 x 1-3/4	LIMIT SWITCH MNT
B	F-HNF-#10C		8	HN 10-24, FLNG., SERR.	LIMIT SWITCH MNT
C	F-THM-06C16		2	THMS 3/8-16 x 1, SLT., SERR.	MNT PLT MNT
C	F-HNF-06C		2	HN 3/8-16, FLNG., SERR.	MNT PLT MNT
D	F-THM-04C12		4	THMS 1/4-20 x 3/4, SLT., SERR.	CONTROL BOX MNT
D	F-HNF-04C		4	HN 1/4-20, FLNG., SERR.	CONTROL BOX MNT
E	F-THM-04C12		4	THMS 1/4-20 x 3/4, SLT., SERR.	CONTROL BOX MPC
E	F-HNF-04C		4	HN 1/4-20, FLNG., SERR.	CONTROL BOX MPC
F	F-THM-04C08		6	THMS 1/4-20 x 1/2, SLT., SERR.	CONTROLLER MNT
G	F-PHM-#6C12		4	PHMS #6-32 x 3/4	TERMINAL STRIP MNT
G	F-HNF-#6C		4	HN #6-32, FLNG., SERR.	TERMINAL STRIP MNT
H	F-PHM-#6C12		2	PHMS #6-32 x 3/4	RELAY MNT
H	F-HNF-#6C		2	HN #6-32, FLNG., SERR.	RELAY MNT
H	F-LWE-#6		2	LW #6, EXTERNAL STAR	RELAY MNT
I	F-PHM-#6C12		1	PHMS #6-32 x 3/4	GROUND
I	F-HNF-#6C		2	HN #6-32, FLNG., SERR.	GROUND

Model 2800 Hillco Leveling System

CABLES AND WIRES

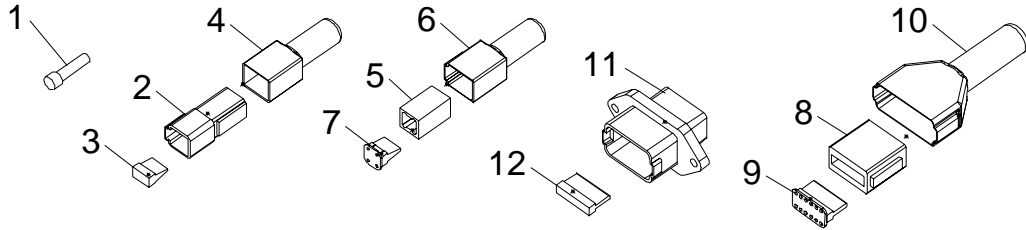

Model 2800 Hillco Leveling System

ELECTRICAL CONNECTORS					
REF.	PART NO.	SN	QTY.	PART NAME	DESCRIPTION
NS	EC-100165		24	SOCKET, ELECTRICAL	
NS	EC-100164		24	PIN, ELECTRICAL	
1	EC-100628		7	PLUG, SEALING, 18 GAUGE	
2	EC-100554		1	RECEPTACLE, 6 PIN	
3	EC-100551		1	WEDGE, 6 PIN	
4	EC-100549		1	BOOT, 6 PIN	
5	EC-100553		1	PLUG, 6 SOCKET	
6	EC-100550		1	BOOT, 6 SOCKET	
7	EC-100552		1	WEDGE, 6 SOCKET	
8	EC-100161		2	PLUG, 12 SOCKET	
9	EC-100163		2	WEDGE, 12 SOCKET	
10	EC-100167		2	BOOT, 12 SOCKET	
11	EC-100555		2	RECEPTACE, 12 PIN MOUNT FLANGE	
12	EC-100162		2	WEDGE, 12 PIN	
NS	EC-102021		2	GASKET, 12 PIN MOUNT FLANGE	
NS	EC-102187		1	CONNECTOR, SPLICE	
WIRES AND CABLES					
NS	LA-235121		1	WIRE KIT, CONTROL BOX	
NS	LA-235471		1	OPTIONAL RELAY KIT, LATERAL TILT	WITHOUT FIELD TRACKER
NS	LA-236731		1	OPTIONAL RELAY KIT, AUTO CENTER DISABLE	WITH FIELD TRACKER
NS	LA-235131		1	CABLE A	CONTROL PANEL TO CONTROL BOX
NS	LA-235141		1	CABLE B	CONTROL BOX TO MANIFOLD
NS	LA-235151		1	CABLE C	LEFT LIMIT SWITCH TO CONTROL BOX
NS	LA-235161		1	CABLE D	RIGHT LIMIT SWITCH TO CONTROL BOX
WIRE AND CABLE FASTENERS					
NS	F-PHM-#10C08		2	OPTIONAL PHMS 10-24 x 1/2	LATERAL TILT RELAY KIT
NS	F-HNF-#10C		2	OPTIONAL HN 10-24, FLNG., SERR.	LATERAL TILT RELAY KIT

8 HYDRAULIC COMPONENTS

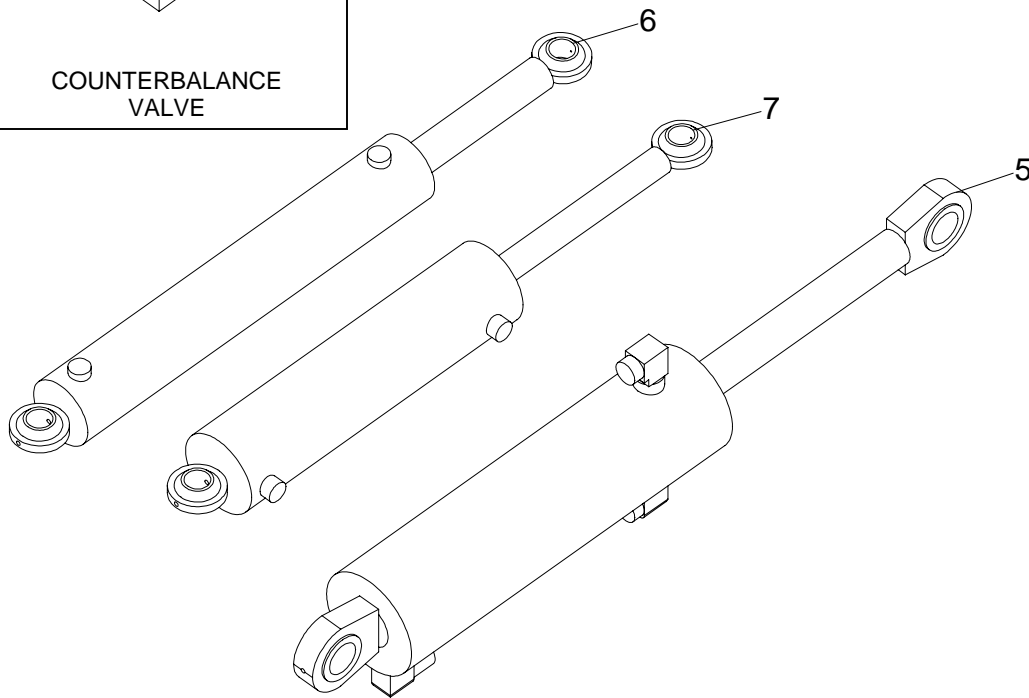
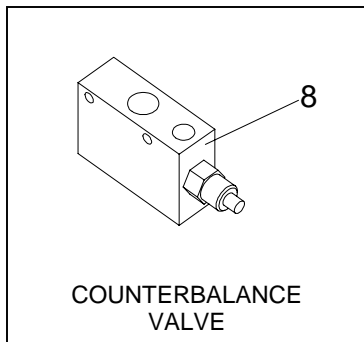
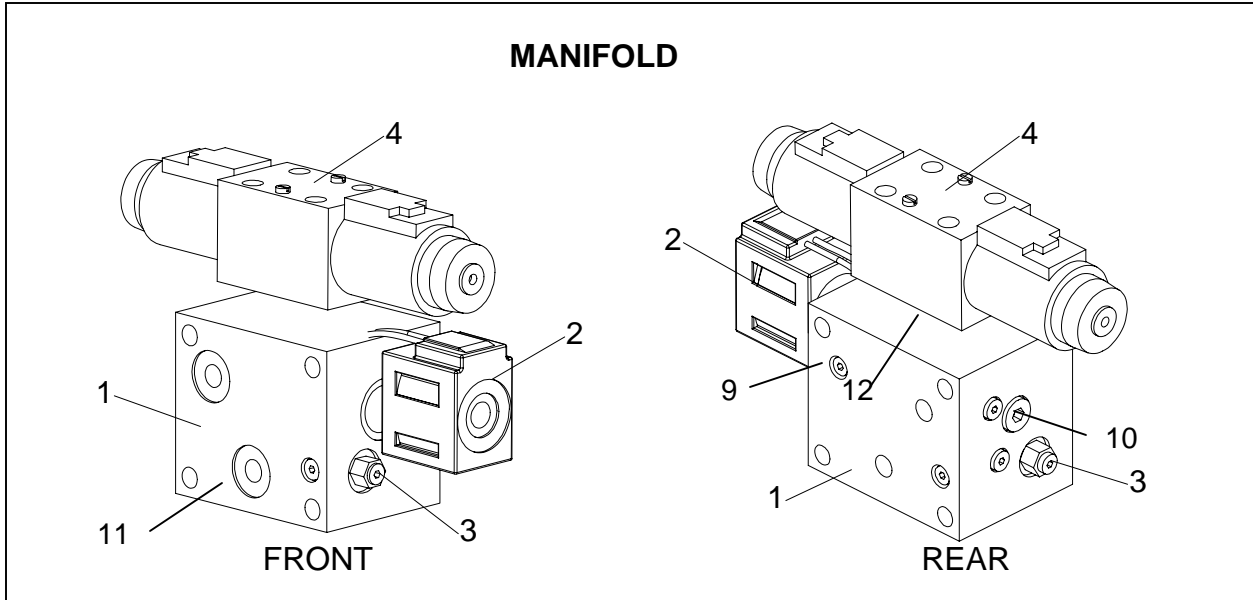

Model 2800 Hillco Leveling System

HYDRAULIC COMPONENTS					
REF.	PART NO.	SN	QTY.	PART NAME	DESCRIPTION
1	HC-103226		1	MANIFOLD ASM, LEVELING	
..	HC-100338		1	SEAL KIT, SUB PLATE O-RING	
NS	F-SHC-10M200E		4	BEFORE JJCO267248 MM SHC 10.9 - 10 X 1.5 X 200	
NS	F-SHC-10M150E		4	JJCO267248 AND AFTER MM SHC 10.9 - 10 X 1.5 X 150	
2	HC-102099		1	CARTRIDGE ASM, HIGH SPEED LEVELING	
..	HC-102090		1	COIL, HIGH SPEED LEVELING	
..	HC-102086		1	CARTRIDGE, HIGH SPEED LEVELING	
..	HC-102088		1	KIT, HIGH SPEED LEVELING CARTRIDGE SEAL KIT	BUNA (STANDARD)
..	HC-102087		1	KIT, HIGH SPEED LEVELING CARTRIDGE SEAL KIT	VITON (PREMIUM)
3	HC-134571		2	CARTRIDGE, LOAD SENSE CHECK	
..	HC-134581		1	O-RING, LOAD SENSE VALVE	
..	HC-134601		1	O-RING, LOAD SENSE VALVE	
..	HC-134611		1	BACK-UP, LOAD SENSE VALVE	
4	HC-103224		1	VALVE, DIRECTIONAL CONTROL, LEFT-RIGHT LEVELING	
..	HC-134591		1	SEAL KIT, DIRECTIONAL CONTROL VALVE	
..	HC-103223		2	COIL, DIRECTIONAL CONTROL VALVE	
NS	HC-134221		1	ORIFICE, HIGH SPEED	
NS	HC-134231		1	ORIFICE, LOW SPEED	
5	HC-103227		2	CYLINDER, MAIN 2800	
..	HC-134251		2	KIT, SEAL, MAIN CYLINDER	
6	HC-100706		1	CYLINDER, SLAVE	
..	HC-134191		1	KIT, SEAL, SLAVE CYLINDER	
7	HC-101842		1	CYLINDER, MASTER	
..	HC-134201		1	KIT, SEAL, MASTER CYLINDER	
8	HC-101265		2	VALVE, COUNTERBALANCE	
..	HC-102125		2	BODY, COUNTERBALANCE VALVE	
..	HC-102068		2	CARTRIDGE, COUNTERBALANCE VALVE	
..	HC-100805		2	KIT, SEAL, COUNTERBALANCE VALVE	BUNA (STANDARD)
..	HC-102025		2	KIT, SEAL, COUNTERBALANCE VALVE	VITON (PREMIUM)
NS	HC-101870	1001-1025	36	TUBE, NYLON	
NS	HC-101878	1001-1025	1	COUPLER, PIPE	
NS	MC-100764	1001-1016	18 in.	LOOM, SPIRAL, BLACK, 3-1/2	
NS	HC-133111	1017-	2	SLEEVE, NYLON ABRASION, 20 IN.	
NS	HC-133121	1017-	2	SLEEVE, NYLON ABRASION, 32 IN.	
9	HA-P-2MO	1018-	1	PLUG, #2 MORB	
10	HA-P-6MO	1018-	1	PLUG, #6 MORB	
11	HC-135021	1018-	1	O-RING, MANIFOLD	13/16 X 1, 3/32 CS
12	HC-100338		1	O-RING KIT, SUBPLATE	2-012 (QTY 4)

Model 2800 Hillco Leveling System

HYDRAULIC HOSES FOR SN 1001-1035

NOTE: BULKHEAD POSITIONS NUMBERED 1 THRU 5. (1 IS TOP, 5 IS BOTTOM)

PART NO.	SN	QTY.	PART NAME	WHERE USED
LEVELING AND TRIM MANIFOLDS TO BULKHEAD				
LA-102639	1001-1016	1	1/4" 100R2 24 IN. #4 FORS X #4 FORS	LOAD SENSE LINES BETWEEN MANIFOLDS
LA-133101	1017-	1	1/4" 100R2 26 IN. #4 FORS X #6 FORS 90	LOAD SENSE LINES BETWEEN MANIFOLDS
LA-102634		1	1/2" 100R2 95 IN. 8FJIC X 8FJIC	TRIM MANIFOLD CLOCKWISE TO #2 BULKHEAD LEFT
				AND TRIM MANIFOLD CCLOCKWISE TO #3 BULKHEAD LEFT
LA-102638		2	1/4" 100R2 92 IN. #4 FJIC X #4 FJIC	LEVELING VALVE TO BULKHEAD #5 FRONT LEFT
LA-102640		1	1/2" 100R2 118 IN. 8FJIC X 8FJIC	BULKHEAD #4 FRONT LEFT TO LEVELING VALVE B PORT
BULKHEAD TO MASTER AND SLAVE CYLINDER				
LA-101797		1	1/4" 100R2 24.5 IN. 4FJIC X 4FJIC	MASTER CYLINDER BASE TO BULKHEAD #2 BACK RIGHT
LA-101798		1	1/4" 100R2 28 IN. 4FJIC X 4FJIC	MASTER CYLINDER ROD TO BULKHEAD #3 BACK RIGHT
LA-101799		1	1/4" 100R2 128 IN. 4FJIC X 4FJIC	BULKHEAD #2 FRONT RIGHT TO SLAVE CYLINDER BASE
LA-101800		1	1/4" 100R2 143 IN. 4FJIC x 4FJIC	BULKHEAD #3 FRONT RIGHT TO SLAVE CYLINDER ROD
BULKHEAD TO MAIN LEVELING CYLINDER				
LA-102669		2	1/4" 100R2 8.375 IN. 4FJIC X 4FJIC	POCV PORT #3 TO MAIN CYLINDER ROD PORT
LA-102633		2	1/4" 100R2 22 IN. 4FJIC X 4FJIC	RIGHT POCV PORT #4 TO BULKHEAD #1 BACK RIGHT
				AND LEFT POCV PORT #4 TO BULKHEAD #1 LEFT
LA-102636		2	1/2" 100R2 19 IN. #8 FJIC X #8 FJIC	LEFT POCV #2 TO BULKHEAD #5 LEFT BACK
				RIGHT POCV #2 TO BULKHEAD #4 RIGHT
LA-102670		2	1/2" 100R2 30 IN. #8 FJIC X #8 FJIC	LEFT ROD TO BULKHEAD #4 BACK LEFT
				RIGHT ROD TO BULKHEAD #5 RIGHT
BRAKE				
LA-101803		1	1/4" 100RS 56 IN. #4 FORS X #4 FORS	FOOT AND INCH VALVE
LA-101804		1	3/8" 100R2 39 IN. #6 FORS 90 X #8 FORS	RIGHT HAND BRAKE
LA-102635		1	3/8" 100R2 58 IN. #6 FORS 90 X #6 FORS	LEFT HAND BRAKE
LA-101808		1	1/4" PUSH-LOCK, 20" LONG	BULKHEAD #1 FRONT RIGHT TO BRAKE VALVE DRAIN PORT
HYDROSTAT				
LA-102097		1	BEFORE JJCO193725 1" 100R15 44 IN. W/ 1" CODE 62 SPLIT FLANGE ENDS	HYDROSTAT
LA-102098		1	BEFORE JJCO193725 1" 100R1 46 IN. W/ #16 FORS X #16 FORS	HYDROSTAT
LA-101809		1	1" 6000 PSI WP 18 IN. W/ 1" CODE 62 SPLIT FLANGE ENDS	HYDROSTAT
GREASE				
LA-133321	1036-	1	3/16" 100R1 48 IN. GREASE HOSE 1/8 MPIPE X 1/8 MPIPE	REMOTE GREASE LINE FROM MASTER ROD TO SIDE
LA-133331	1036-	1	3/16" 100R1 11.5 IN. GREASE HOSE 1/8 MPIPE X 1/8 MPIPE	REMOTE GREASE LINE FROM MASTER BASE TO SIDE
LA-133341	1036-	2	3/16" 100R1 9.5 IN. GREASE HOSE 1/8 MPIPE X 1/8 MPIPE	REMOTE GREASE LINE FROM LEVELING CYLINDER BASE TO SIDE
LA-133351	1036-	1	3/16" 100R1 30 IN. GREASE HOSE 1/8 MPIPE X 1/8 MPIPE	REMOTE GREASE LINE FROM MAIN PIVOT PIN TO SIDE

Model 2800 Hillco Leveling System
HYDRAULIC HOSES FOR SN 1036 THRU 1074

NOTE: BULKHEAD POSITIONS NUMBERED 1 THRU 5. (1 IS TOP, 5 IS BOTTOM)				
PART NO.	SN	QTY.	PART NAME	WHERE USED
LEVELING AND TRIM MANIFOLDS TO BULKHEAD				
LA-133101		1	1/4" 100R2 HOSE 26" #6 FORS 90 X #4 FORS	LOAD SENSE LINE
LA-133441		1	1/2" 100R2 HOSE 95" #8 FORS X #8 FORS	LEVELING VALVE PORT A TO BULKHEAD #5 FRONT LEFT
LA-133451		1	1/2" 100R2 HOSE 92" #8FORS X #8 FORS	LEVELING VALVE PORT B TO BULKHEAD #4 FRONT LEFT
LA-133521		2	1/4" 100R2 HOSE 92" #4 FORS X #4 FORS	BULKHEAD #2 LEFT TO TRIM MAN CW AND BULKHEAD #3 LEFT TO TRIM MAN CCW
BULKHEAD TO MAIN LEVELING CYLINDER				
LA-133371		1	1/4" 100R2 HOSE 26" #4FORS X #4 FORS	POCV PORT #3 (RIGHT)TO BULKHEAD #5 (FRONT RIGHT)
LA-133381		1	1/4" 100R2 HOSE 50" #4FORS X #4 FORS	POCV PORT #3 (LEFT) TO BULKHEAD #4 (FRONT RIGHT)
LA-133391		2	1/4" 100R2 HOSE 20-1/2" #4 FORS X #4 FORS	RIGHT POCV PORT #4 TO BULKHEAD #1 BACK RIGHT AND LEFT POCV PORT #4 TO BULKHEAD #1 LEFT
LA-133491		1	1/2" 100R2 HOSE 18-1/2" #8 FORS X #8 FORS	LEFT POCV #2 TO BULKHEAD #5 BACK LEFT
LA-133761		1	1/2" 100R2 HOSE 19-1/4" #8 FORS X #8 FORS	RIGHT POCV #2 TO BULKHEAD #4 RIGHT
LA-133501		1	1/2" 100R2 HOSE 30" #8 FORS X #8 FORS	LEFT MAIN ROD TO BULKHEAD #4 BACK LEFT
LA-133511		1	1/2" 100R2 HOSE 29-1/2" #8 FORS X #8 FORS	RIGHT MAIN ROD TO BULKHEAD #5 BACK RIGHT
BULKHEAD TO MASTER AND SLAVE CYLINDER				
LA-133421		1	1/4" 100R2 HOSE 128" #4 FORS X #4 FORS	BULKHEAD # 2 FRONT RIGHT TO SLAVE CYLINDER BASE
LA-133431		1	1/4" 100R2 HOSE 143" #4 FORS X #4 FORS	BULKHEAD #3 FRONT RIGHT TO SLAVE CYLINDER ROD
LA-133751		1	1/4" 100R2 HOSE 28-1/2" #4 FORS X #4 FORS	MASTER CYLINDER ROD TO BULKHEAD #3 BACK RIGHT
LA-133401		1	1/4" 100R2 HOSE 24" #4 FORS X #4 FORS	MASTER CYLINDER BASE TO BULKHEAD #2 BACK RIGHT
BRAKE				
LA-133471		1	1/4" 100R2 HOSE 56" #4 FORS X #4 FORS	FOOT-N-INCH VALVE (ATTENUATOR)
LA-133481		1	3/8" 100R2 HOSE 39" #6 FORS 90 X #8 FORS	RIGHT BRAKE HOSE
HC-101808		1	1/4" PUSH-LOK 20" NO ENDS	BULKHEAD # 1 FRONT RIGHT TO BRAKE VALVE DRAIN PORT
LA-133461		1	3/8" 100R2 HOSE 58" #6 FORS 90 X #6 FORS	LEFT BRAKE HOSE (2800)
HYDROSTAT				
LA-102097		1	BEFORE JJCO193725 1" 100R15 HOSE 44" W/ 1" CODE 62 FLANGE ENDS	HYDROSTATIC HOSE
LA-102098		1	BEFORE JJCO193725 1" 100R1 HOSE 46" #16 FORS X #16 FORS	HYDROSTATIC HOSE
LA-101809		1	1" 6000 PSI WP 18 IN W/1 IN CODE 62 SPLIT FLANGE ENDS	HYDROSTATIC FORWARD PROPUSION HOSE EXTENSION
GREASE				
LA-133321		1	3/16 R1 48 IN GREASE HOSE 1/8 MPT X 1/8 MPT	REMOTE GREASE LINE FROM MASTER ROD
LA-133331		1	3/16 R1 12 IN GREASE HOSE 1/8 MPT X 1/8 MPT	REMOTE GREASE FROM MASTER BASE
LA-133341		2	3/16 R1 9-1/2 IN GREASE HOSE 1/8 MPT X 1/8 MPT	REMOTE GREASE LINE FROM LEVELING CYLINDER BASES TO SIDE
LA-133351		1	3/16 R1 31-1/2 IN GREASE HOSE 1/8 MPT X 1/8 MPT	REMOTE GREASE LINE FROM MAIN PIVOT PIN TO SIDE

Model 2800 Hillco Leveling System

HYDRAULIC HOSES FOR SN 1075 AND AFTER

NOTE: BULKHEAD POSITIONS NUMBERED 1 THRU 5. (1 IS TOP, 5 IS BOTTOM)

PART NO.	SN	QTY.	PART NAME	WHERE USED
LEVELING AND TRIM MANIFOLDS TO BULKHEAD				
LA-133101		1	1/4" 100R2 HOSE 26" #6 FORS 90 X #4 FORS	LOAD SENSE LINE
LA-133441		1	1/2" 100R2 HOSE 95" #8 FORS X #8 FORS	LEVELING VALVE PORT A TO BULKHEAD #1 TOP LEFT
LA-133451		1	1/2" 100R2 HOSE 92" #8FORS X #8 FORS	LEVELING VALVE PORT B TO BULKHEAD #2 TOP LEFT
LA-133521		2	1/4" 100R2 HOSE 92" #4 FORS X #4 FORS	BULKHEAD #2 LEFT TO TRIM MAN CW AND BULKHEAD #3 LEFT TO TRIM MAN CCW
BULKHEAD TO MAIN LEVELING CYLINDER				
LA-133372		1	1/4" 100R2 HOSE 25" #4FORS X #4 FORS, 90	POCV PORT #3 (RIGHT) TO BULKHEAD #1 (TOP RIGHT)
LA-133382		1	1/4" 100R2 HOSE 66" #4FORS X #4 FORS	POCV PORT #3 (LEFT) TO BULKHEAD #2 (TOP RIGHT)
LA-133392		1	1/4" 100R2 HOSE 22" #4 FORS X #4 FORS	RIGHT POCV PORT #4 TO BULKHEAD #5 RIGHT
LA-133392		1	1/4" 100R2 HOSE 22" #4 FORS X #4 FORS	LEFT POCV PORT #4 TO BULKHEAD #5 LFT
LA-133492		1	1/2" 100R2 HOSE 18" #8 FORS X #8 FORS	LEFT POCV #2 TO BULKHEAD #1 BOTTOM LEFT
LA-133762		1	1/2" 100R2 HOSE 18-1/2" #8 FORS X #8 FORS	RIGHT POCV #2 TO BULKHEAD #2 BOTTOM RIGHT
LA-133502		1	1/2" 100R2 HOSE 27" #8 FORS X #8 FORS	LEFT MAIN ROD TO BULKHEAD #2 BOTTOM LEFT
LA-133512		1	1/2" 100R2 HOSE 28" #8 FORS X #8 FORS	RIGHT MAIN ROD TO BULKHEAD #1 BOTTOM RIGHT
BULKHEAD TO MASTER AND SLAVE CYLINDER				
LA-133421		1	1/4" 100R2 HOSE 128" #4 FORS X #4 FORS	BULKHEAD # 2 FRONT RIGHT TO SLAVE CYLINDER BASE
LA-133431		1	1/4" 100R2 HOSE 143" #4 FORS X #4 FORS	BULKHEAD #3 FRONT RIGHT TO SLAVE CYLINDER ROD
LA-133752		1	1/4" 100R2 HOSE 29" #4 FORS X #4 FORS	MASTER CYLINDER ROD TO BULKHEAD #3 BOTTOM RIGHT
LA-133402		1	1/4" 100R2 HOSE 23-1/2" #4 FORS X #4 FORS	MASTER CYLINDER BASE TO BULKHEAD #4 BOTTOM RIGHT
BRAKE				
LA-133471		1	1/4" 100R2 HOSE 56" #4 FORS X #4 FORS	FOOT-N-INCH VALVE (ATTENUATOR)
LA-133481		1	3/8" 100R2 HOSE 39" #6 FORS 90 X #8 FORS	RIGHT BRAKE HOSE
HC-101808		1	1/4" PUSH-LOK 20" NO ENDS	BULKHEAD # 1 FRONT RIGHT TO BRAKE VALVE DRAIN PORT
LA-133461		1	3/8" 100R2 HOSE 58" #6 FORS 90 X #6 FORS	LEFT BRAKE HOSE (2800)
HYDROSTAT				
LA-102097		1	BEFORE JJCO193725 1" 100R15 HOSE 44" W/ 1" CODE 62 FLANGE ENDS	HYDROSTATIC HOSE
LA-102098		1	BEFORE JJCO193725 1" 100R1 HOSE 46" #16 FORS X #16 FORS	HYDROSTATIC HOSE
LA-101809		1	1" 6000 PSI WP 18 IN W/1 IN CODE 62 FLANGE ENDS	HYDROSTATIC FORWARD PROPUSION HOSE EXTENSION
GREASE				
LA-133322	1078-	1	3/16 R1 55 IN GREASE HOSE 1/8 MPT X 1/8 MPT	REMOTE GREASE LINE FROM MASTER ROD
LA-133331		1	3/16 R1 11-1/2 IN GREASE HOSE 1/8 MPT X 1/8 MPT	REMOTE GREASE FROM MASTER BASE
LA-133341		2	3/16 R1 9-1/2 IN GREASE HOSE 1/8 MPT X 1/8 MPT	REMOTE GREASE LINE FROM LEVELING CYLINDER BASES TO SIDE
LA-133351		1	3/16 R1 31-1/2 IN GREASE HOSE 1/8 MPT X 1/8 MPT	REMOTE GREASE LINE FROM MAIN PIVOT PIN TO SIDE

Model 2800 Hillco Leveling System

HYDRAULIC ADAPTERS FOR SN 1001-1035

HYDRAULIC ADAPTERS FOR SN 1001-1035				
PART NO.	SN	QTY.	PART NAME	WHERE USED
BULKHEAD MOUNT				
HA-J-8MJ8MJ		1	#8 MJIC BULKHEAD RUN TEE	BULKHEAD MOUNT #5 BOTTOM
HA-L-8FJ8MJ		1	#8 FJIC X #8 MJIC, 90	BULKHEAD MOUNT #5 BOTTOM
HA-J-8MJ8MJ		1	#8 MJIC BULKHEAD RUN TEE	BULKHEAD MOUNT #4
HA-L-8FJ8MJ		1	#8 FJIC X #8 MJIC, 90	BULKHEAD MOUNT #4
HA-J-4MJ4MJ		1	#4 MJIC BULKHEAD RUN TEE	BULKHEAD MOUNT #5 TOP
HA-L-4FJ4MJ		1	#4 FJIC X #4 MJIC, 90	BULKHEAD MOUNT #5 TOP RIGHT
HA-J-4MJ4MJ		1	#4 MJIC BULKHEAD RUN TEE	BULKHEAD MOUNT #2
HA-L-4FJ4MJ		1	#4 FJIC X #4 MJIC, 90	BULKHEAD MOUNT #2
HA-J-4MJ4MJ		1	#4 MJIC BULKHEAD RUN TEE	BULKHEAD MOUNT #3
HA-L-4FJ4MJ		1	#4 FJIC X #4 MJIC, 90	BULKHEAD MOUNT #2
HA-L-8MJ8MO		1	#8 MJIC X #8 MORB, 90	BULKHEAD MOUNT #3
MAIN CYLINDER AND PILOT OPERATED CHECK VALVE				
HA-L-8MO8MO		1	#8 MORB X #8 MORB, 90	LEFT PILOT OP CHECK VALVE #1
HA-L-8MJ8MO		1	#8 MJIC X #8 MORB, 90	LEFT PILOT OP CHECK VALVE #2
HA-L-4MJ8MO		1	#4 MJIC X #8 MORB, 90	LEFT PILOT OP CHECK VALVE #3
HA-L-4MJ6MO		1	#4 MJIC X #6 MORB, 90	LEFT PILOT OP CHECK VALVE #4
LM-206851		1	#8 MJIC X #8 MORB, 90, DRILLED 1/8 NPT LEFT	RIGHT MAIN CYLINDER ROD
HA-L-2MP4MJ		1	#2 MPIPE X #4 MJIC, 90	LEFT MAIN CYLINDER ROD
HA-L-8MO8MO		1	#8 MORB X #8 MORB, 90	RIGHT PILOT OP CHECK VALVE #1
HA-L-8MJ8MO		1	#8 MJIC X #8 MORB, 90	RIGHT PILOT OP CHECK VALVE #2
HA-L-4MJ8MO		1	#4 MJIC X #8 MORB, 90	RIGHT PILOT OP CHECK VALVE #3
HA-L-4MJ6MO		1	#4 MJIC X #6 MORB, 90	RIGHT PILOT OP CHECK VALVE #4
LM-206841		1	#8 MJIC X #8 MORB, 90, DRILLED 1/8 NPT RIGHT	RIGHT MAIN CYLINDER ROD
HA-L-2MP4MJ		1	#2 MPIPE X #4 MJIC, 90	RIGHT MAIN CYLINDER ROD
HFS-0404FJPL		2	#4 X 1/4 FJIC PUSHLOCK STR.	PILOT OPERATED CHECK VALVE VENT
HFS-0606FJPL		1	#6 X 3/8 FJIC PUSHLOCK, STR.	PILOT OPERATED CHECK VALVE VENT
HA-S-6FO8MO		1	#6 FORB X #8 MORB, STR.	PILOT OPERATED CHECK VALVE VENT
HA-T-6MJ6MO		1	#6 MORB STRAIGHT THREAD RUN TEE	PILOT OPERATED CHECK VALVE VENT
HA-S-4MJ6FJ		1	#4 MJIC X #6 FJIC, STR.	PILOT OPERATED CHECK VALVE VENT
MASTER AND SLAVE CYLINDER				
HA-L-4MJ6MO		1	#4 MJIC X #6 MORB, 90	TRIM MASTER BUTT PORT
HA-L-4MJ6MO		1	#4 MJIC X #6 MORB, 90	TRIM MASTER ROD PORT
HA-L-4MJ6MO		1	#4 MJIC X #6 MORB, 90	TRIM SLAVE BUTT PORT
HA-L-4MJ6MO		1	#4 MJIC X #6 MORB, 90	TRIM SLAVE ROD PORT
LEVELING AND TRIM MANIFOLDS				
HA-D-8MJ8MO		1	#8 MJIC X #8 MORB, 90 LONG DROP	LEVELING MANIFOLD LEFT
HA-L-4MJ6MO		4	#4 MJIC x #6 MORB, 90	FIELD TRACKER MANIFOLD CLOCKWISE
HA-M-4MF4FF	1001-1016	1	#4 FORS SWIVEL NUT RUN TEE	LOAD SENSE PORT ON CASE-IH MANIFOLD
HA-M-6MF6FF	1017-	1	#6 FORS SWIVEL NUT RUN TEE	LOAD SENSE PORT ON CASE-IH MANIFOLD
HA-L-4MF6MO		1	#4 MORS X #6 MORB, 90	LOAD SENSE PORT (LS) ON HILLCO LEV. MAN
HYDROSTAT				
HC-101843		1	KIT, HOSE COUPLER, CODE 62	
HC-101843		1	BEFORE JJCO193725 KIT, HOSE COUPLER, CODE 62	
GREASE				
HC-101942	1001-1025	1	BRASS COMPRESSION, 90	REMOTE GREASE ZERK
HC-101941	1001-1025	1	BRASS COMPRESSION, STR.	REMOTE GREASE ZERK
HA-L-2FP2MP	1036-	2	1/8 MPIPE X 1/8 FPIPE, 90	MASTER CYLINDER BASE AND MAIN PIVOT PIN
HA-F-2FP2MP	1036-	2	1/8 MPIPE X 1/8 FPIPE, 45	LEVELING CYLINDER BASE
F-PZS-04F	1036-	5	1/4-28 STRAIGHT ZERK	ALL GREASE LINES
HA-S-2MN2FP	1036-	5	1/8" NPSM X 1/8" FPT BULKHEAD CONNECTOR	BULKHEAD CONNECTORS
HA-NJ-2FN	1036-	5	1/8 NPSM BULKHEAD LOCKNUT	BULKHEAD CONNECTORS

Model 2800 Hillco Leveling System
HYDRAULIC ADAPTERS FOR SN 1036 AND AFTER

HYDRAULIC ADAPTERS FOR SN 1036 AND AFTER				
PART NO.	SN	QTY.	PART NAME	WHERE USED
BULKHEAD MOUNT				
HA-J-8MF8MF		1	#8MORS X #8MORS X #8MORS BULKHEAD RUN TEE	BULKHEAD MNT #5 (BOTTOM)
HA-S-8FF4MF		1	#8FORS X #4MORS REDUCER	BULKHEAD MNT # 5
HA-N-8FF		1	#8 ORS NUT	BULKHEAD MNT # 5
HA-NB-8FF		1	#8 ORS BULKHEAD NUT	BULKHEAD MNT # 5
HA-K-8MF8FF		1	#8FORS X #8MORS X #8MORS SWIVEL NUT BRANCH TEE	BULKHEAD MNT # 5
HA-J-8MF8MF		1	#8MORS X #8MORS X #8MORS BULKHEAD RUN TEE	BULKHEAD MNT # 4
HA-S-8FF4MF		1	#8FORS X #4MORS REDUCER	BULKHEAD MNT # 4
HA-N-8FF		1	#8 ORS NUT	BULKHEAD MNT # 5
HA-NB-8FF		1	#8 ORS BULKHEAD NUT	BULKHEAD MNT # 4
HA-K-8MF8FF		1	#8FORS X #8MORS X #8MORS SWIVEL NUT BRANCH TEE	BULKHEAD MNT # 4
HA-J-4MF4MF		1	#4MORS X #4MORS X #4MORS BULKHEAD RUN TEE	BULKHEAD MNT #3
HA-NB-4FF		1	#4 ORS BULKHEAD NUT	BULKHEAD MNT #3
HA-L-4FF4MF		1	#4 FORS X #4 MORS 90 DEG	BULKHEAD MNT #3
HA-J-4MF4MF		1	#4MORS X #4MORS X #4MORS BULKHEAD RUN TEE	BULKHEAD MNT # 2
HA-NB-4FF		1	#4 ORS BULKHEAD NUT	BULKHEAD MNT #3
HA-L-4FF4MF		1	#4 FORS X #4 MORS 90 DEG	BULKHEAD MNT # 2
HA-J-4MF4MF		1	#4MORS X #4MORS X #4MORS BULKHEAD RUN TEE	BULKHEAD MNT # 1
HA-NB-4FF		1	#4 ORS BULKHEAD NUT	BULKHEAD MNT #3
HA-L-4FF4MF		1	#4 FORS X #4 MORS 90 DEG	BULKHEAD MNT # 1 (TOP)
MAIN CYLINDER AND PILOT OPERATED CHECK VALVE				
HA-L-8MF8MO		2	#8MORS X #8MORB 90 DEG	MAIN CYLINDER ROD (LEFT & RIGHT)
HA-F-8MF8MO		2	#8 MORS X #8 MORB 45 DEG	LEFT AND RIGHT PILOT OP CHECK VALVE #2
HA-F-4MF6MO		2	#4 MORS X #6 MORB 45 DEG	LEFT AND RIGHT PILOT OP CHECK VALVE #4
HA-L-8MO8MO		2	# 8 MORB X #8 MORB 90 DEG	LEFT AND RIGHT PILOT OP CHECK VALVE #1
HA-L-4MF8MO		2	#4 MORS X #8 MORB 90 DEG	LEFT AND RIGHT PILOT OP CHECK VALVE #3
HA-S-6FO8MO		1	#6 FORB X #8 MORB REDUCER	PILOT OPERATED CHECK VALVE VENT
HA-S-4FF4MJ		1	#4 MJIC X #4 FORS	PILOT OPERATED CHECK VALVE VENT
HA-T-6MJ6MO		1	#6 MORB STRAIGHT THREAD RUN TEE	PILOT OPERATED CHECK VALVE VENT
HA-S-4MJ6FJ		1	#4 MJIC X #6 FJIC REDUCER	PILOT OPERATED CHECK VALVE VENT
HFS-0404FJPL		2	#4 X 1/4 FJIC PUSHLOCK	PILOT OPERATED CHECK VALVE VENT
HFS-0606FJPL		1	#6 X 3/8 FJIC PUSHLOCK	PILOT OPERATED CHECK VALVE VENT
MASTER AND SLAVE CYLINDER				
HA-F-4MF6MO		1	#4 MORS X #6 MORB 45 DEG	TRIM MASTER BUTT PORT
HA-L-4MF6MO		1	#4 MORS X #6 MORB 90 DEG	TRIM MASTER ROD PORT
HA-L-4MF6MO		1	#4 MORS X #6 MORB 90 DEG	TRIM SLAVE BUTT PORT
HA-L-4MF6MO		1	#4 MORS X #6 MORB 90 DEG	TRIM SLAVE ROD PORT
LEVELING AND TRIM MANIFOLDS				
HA-L-8MF8MO		1	#8 MORS X #8 MORB 90 DEG	LEVELING VALVE PORT A
HA-S-8MF8MO		1	#8MORS X #8MORB STRAIGHT	LEVELING VALVE PORT B
HA-L-8FF8MF		1	#8 FORS X #8 MORS 90 DEG	LEVELING VALVE PORT B
HA-L-4MF6MO		2	#4 MORS X #6 MORB 90 DEG	FIELD TRACKER VALVE CW AND CCW PORTS
HA-M-6MF6FF		1	#6 FORS SWIVEL NUT RUN TEE	LOAD SENSE LINE TO CASE LOAD SENSE LINE
HA-L-4MF6MO		1	#4 MORS X #6 MORB 90 DEG	LOAD SENSE PORT (LS) ON HILLCO LEV MAN
HYDROSTAT				
HC-101843		1	KIT, HOSE COUPLER, CODE 62	
HC-101843		1	BEFORE JJCO193725 KIT, HOSE COUPLER, CODE 62	
GREASE				
HA-L-2FP2MP	1078-	1	1/8 MPT 90 STREET EL	MAIN PIVOT PIN
HC-135771	1078-	1	1/4-28 MALE X 1/8 FPT 90 DEG	MASTER CYLINDER BASE
HA-L-2FP2MP	1036-1077	2	1/8 MPT 90 STREET EL	MASTER CYLINDER BASE AND MAIN PIVOT PIN
HC-135881	1078-	1	1/4-28 MALE X 1/8 FPT STR.	MASTER CYLINDER ROD
HC-135761	1078-	2	1/4-28 MALE X 1/8 FPT 45 DEG	LEVELING CYLINDERS BASE
HA-F-2FP2MP	1036-1077	2	1/8 MPT X 1/8 FPT 45 DEG	LEVELING CYLINDERS BASE
F-PZS-04F	1036-	5	1/4-28 STRAIGHT ZERK	ALL GREASE LINES
HA-S-2MN2FP	1036-	5	1/8 NPSM X 1/8 FPT BULKHEAD CONNECTOR	BULKHEAD CONNECTORS
HA-NJ-2FN	1036-	5	1/8 NPSM BULKHEAD LOCKNUT	BULKHEAD CONNECTORS

Model 2800 Hillco Leveling System

9 MISCELLANEOUS

LABELS, LITERATURE, AND HOSE CLAMPS				
PART NO.	SN	QTY.	PART NAME	DESCRIPTION
DECALS AND LITERATURE				
LL20-100773		2	DECAL, GRAY	HILLCO 2000 LEVELING SYSTEM
LL20-100782		1	LABEL, SAFETY	CAUTION LEVELING SYSTEM CAB
LL20-100783		6	LABEL, SAFETY	DANGER CRUSHING HAZARD
LL20-100784		2	LABEL, SAFETY	DANGER PINCH POINT
LL20-100785		1	LABEL, SAFETY	CAUTION MOVING STEP
LL20-100786		1	LABEL, SAFETY	WARNING ELECTRONIC CRUSHING HAZARD
LL20-100787		2	LABEL, SAFETY	CAUTION LEVELING SYSTEM HAZARD
LL20-100788		3	LABEL, SAFETY	DANGER HYDRAULIC HAZARD
LL-133731	1010-	1	LABEL, GREASE 10 HRS	REAR AXLE
LL-133731	1010-	2	LABEL, GREASE 10 HRS	RH OVERCARRIAGE
LL-133741	1010-	1	LABEL, GREASE 50 HRS	RH OVERCARRIAGE
LL-133731	1010-	1	LABEL, GREASE 10 HRS	LH OVERCARRIAGE
LL-133741	1010-	1	LABEL, GREASE 50 HRS	RH TRANS SIDE PLT
LL-133741	1010-	1	LABEL, GREASE 50 HRS	HDR LIFT CYL MNT (MAIN PVT PIN)
LL-133731	1010-	2	LABEL, GREASE 10 HRS	MAIN LEV CYL BOTTOM RH AND LH
D-010223DJC01		1	MANUAL, OPERATOR'S	
D-010310DJC08		1	MANUAL, INSTALLATION	
D010413MDH01 REV 2		1	MANUAL, PARTS	
HOSE CLAMPS AND FASTENERS				
MC-100168	1001-1009	1	CLAMP R/C 1/4H 1-1/4T	TRANSITION RIGHT UP-RIGHT
F-HNF-06C	1001-1009	1	HN 3/8-16, FLNG, SERR	HOSE CLAMP
F-HC5-06C16	1001-1009	1	HC5 3/8-16 X 1	HOSE CLAMP
F-HNF-04C	1010-	1	HN 1/4-20, FLNG, SERR	HOSE CLAMP
F-HC5-04C16	1010-	1	HC5 1/4-20 x 1	HOSE CLAMP
MC-101342	1010-	1	CLAMP R/C 1/4H 1-1/2T	TRANSITION RIGHT UP-RIGHT
MC-100168	1001-1009	2	CLAMP R/C 1/4H 1-1/4T	AXLE FRONT CORNER GUSSET
MC-101342	1010-	2	CLAMP R/C 1/4H 1-1/2T	AXLE FRONT CORNER GUSSET
MC-101343		1	CLAMP R/C 1/4H 2-7/16T	LEFT SIDE OVERCARRIAGE
F-HC5-04C12		3	HC5 1/4-20 x 3/4	HOSE CLAMP
F-HNF-04C		3	HN 1/4-20, FLNG., SERR.	HOSE CLAMP
MC-100768	1026-	2	CLAMP R/C 1/4H 1/2T	REMOTE GREASE HOSE
F-THC-04C12	1026-	1	THREAD CUTTER, HWH 1/4-20 X 3/4	REMOTE GREASE HOSE

Model 2800 Hillco Leveling System

10 PART NUMBER INDEX

Part Number	Page	Part Number	Page	Part Number	Page	Part Number	Page
D-010223DJC01	9-2	F-HC5-10F16	3-2	F-PHM-#10C08	7-4	HA-S-8FF4MF	8-6
D-010310DJC08	9-2	F-HC5-12C88	5-2	F-PHM-#10C28	7-2	HA-S-8MF8MO	8-6
D-010501MDH01	9-2	F-HC8-06C40	2-8	F-PHM-#6C12	7-2	HA-T-6MJ6MO	8-5, 8-6
EC-100008	7-2	F-HC8-08C36	4-2	F-PHMS-06C32	6-2	HC-100338	8-2
EC-100009	7-2	F-HC8-08C48	4-2	F-PHMS-06C40	6-2	HC-100706	2-2, 8-2
EC-100010	7-2	F-HC8-10C24	3-2	F-PHMS-06C56	6-2	HC-100805	8-2
EC-100012	7-2	F-HC8-10C32	2-8, 3-2	F-PR-06X40	6-2	HC-101265	3-2, 8-2
EC-100016	7-2	F-HC8-10C36	3-2	F-PZS-02	2-8	HC-101808	8-4
EC-100018	7-2	F-HC8-10C88	2-8	F-PZS-04F	8-5, 8-6	HC-101842	3-2, 8-2
EC-100161	7-4	F-HC8-12C112	5-2	F-SHC-10M150E	8-2	HC-101843	8-5, 8-6
EC-100162	7-4	F-HC8-12C120	5-2	F-SHC-10M200E	8-2	HC-101870	8-2
EC-100163	7-4	F-HC8-12C136	5-2	F-SHC-20F60E	3-2	HC-101878	8-2
EC-100164	7-4	F-HC8-12C144	5-2	F-SS-06C08	2-8	HC-101941	8-5
EC-100165	7-4	F-HC8-12C160	5-2	F-SSS-06C08	2-8	HC-101942	8-5
EC-100167	7-4	F-HC8-12C168	5-2	F-TCH-#10C08	7-2	HC-102025	8-2
EC-100177	7-2	F-HC8-12C184	5-2	F-TCH-06C12	3-2	HC-102086	8-2
EC-100186	7-2	F-HC8-12C192	5-2	F-THC-04C12	9-2	HC-102087	8-2
EC-100187	7-2	F-HC8-12C56	5-2	F-THM-04C08	7-2	HC-102088	8-2
EC-100549	7-4	F-HC8-12C72	5-2	F-THM-04C12	7-2	HC-102090	8-2
EC-100550	7-4	F-HC8-12C88	5-2	F-THM-06C16	2-8, 7-2	HC-102099	8-2
EC-100551	7-4	F-HC8-12C96	5-2	F-THM-06C96	2-8	HC-102125	8-2
EC-100552	7-4	F-HC8-16C44	4-2	F-THMS-06C16	6-2	HC-103223	8-2
EC-100553	7-4	F-HC8-16C56	4-2	F-THMS-06C24	6-2	HC-103224	8-2
EC-100554	7-4	F-HC8-16C72	4-2	F-UDS-#7X06	3-2	HC-103226	8-2
EC-100555	7-2, 7-4	F-HC8-20C	2-6	HA-D-8MJ8MO	8-5	HC-103227	3-2, 8-2
EC-100557	7-2	F-HC8-20C36	2-6	HA-F-2FP2MP	8-5, 8-6	HC-133111	8-2
EC-100628	7-4	F-HN5-06C	2-8, 3-2	HA-F-4MF6MO	8-6	HC-133121	8-2
EC-100692	7-2	F-HN5-08C	2-8, 3-2	HA-F-8MF8MO	8-6	HC-134191	8-2
EC-101874	7-2	F-HN8-06C	2-8	HA-J-4MF4MF	8-6	HC-134201	8-2
EC-101876	7-2	F-HN8-10C	2-8	HA-J-4MJ4MJ	8-5	HC-134221	8-2
EC-101877	7-2	F-HN8-12C	5-2	HA-J-8MF8MF	8-6	HC-134231	8-2
EC-102021	7-4	F-HNC-24F	4-2	HA-J-8MJ8MJ	8-5	HC-134251	8-2
EC-102187	7-4	F-HNF-#10C	7-2, 7-4	HA-K-8MF8FF	8-6	HC-134571	8-2
EC-133281	7-2	F-HNF-#6C	7-2	HA-L-2FP2MP	8-5, 8-6	HC-134581	8-2
F-CB-06C20	2-8	F-HNF-04C	2-8, 3-2, 7-2, 9-2	HA-L-2MP4MJ	8-5	HC-134591	8-2
F-CB-08C28	2-8	F-HNF-06C	2-8, 6-2, 7-2, 9-2	HA-L-4FF4MF	8-6	HC-134601	8-2
F-EB-04C20	2-8, 3-2	F-HNF-12C	5-2	HA-L-4FJ4MJ	8-5	HC-134611	8-2
F-FHS-05F10	2-8	F-HNJ-08C	2-8	HA-L-4MF6MO	8-5, 8-6	HC-135021	8-2
F-FHS-05F20	2-8	F-HNJ-10C	3-2	HA-L-4MF8MO	8-6	HFS-0404FJPL	8-5, 8-6
F-FW-06	6-2	F-HNJ-40	2-8	HA-L-4MJ6MO	8-5	HFS-0606FJPL	8-5, 8-6
F-FW-10	3-2	F-HNS-05F	2-8	HA-L-4MJ8MO	8-5	LA-101797	8-3
F-FW-12	5-2	F-HNS-06C	2-8	HA-L-8FF8MF	8-6	LA-101798	8-3
F-FWH-06	2-8	F-HNS-08C	2-6, 4-2	HA-L-8FJ8MJ	8-5	LA-101799	8-3
F-FWH-08	2-8	F-HNS-10C	2-8	HA-L-8FJ8MJ	8-5	LA-101800	8-3
F-FWH-10	3-2	F-HNS-10C	3-2	HA-L-8MF8MO	8-6	LA-101803	8-3
F-FWH-12	5-2	F-HNS-16C	4-2	HA-L-8MJ8MO	8-5	LA-101804	8-3
F-HC-12M065E	2-8	F-LW-06	2-8, 3-2	HA-L-8MO8MO	8-5, 8-6	LA-101808	8-3
F-HC-20F60E	3-2	F-LW-06A	2-8	HA-M-4MF4FF	8-5	LA-101809	8-3, 8-4
F-HCT-08C54	2-9	F-LW-08	2-8, 3-2	HA-M-6MF6FF	8-5, 8-6	LA-102097	8-3, 8-4
F-HC5-04C12	9-2	F-LW-10A	2-8, 3-2	HA-N-8FF	8-6	LA-102098	8-3, 8-4
F-HC5-04C16	9-2	F-LW-12A	5-2	HA-NB-4FF	8-6	LA-102633	8-3
F-HC5-06C12	2-8	F-LW-20A	2-6	HA-NB-8FF	8-6	LA-102634	8-3
F-HC5-06C14	2-8	F-LWE-#6	7-2	HA-NJ-2FN	8-5, 8-6	LA-102635	8-3
F-HC5-06C16	3-2	F-LWH-20M	3-2	HA-P-2MO	8-2	LA-102636	8-3
F-HC5-06C16	9-2	F-MB-14NR40	2-8	HA-P-6MO	8-2	LA-102638	8-3
F-HC5-06C20	2-8	F-MB-18NR24	4-2	HA-S-2MN2FP	8-5, 8-6	LA-102639	8-3
F-HC5-08C104	2-6	F-PCL-10X24	2-8	HA-S-4FF4MJ	8-6	LA-102640	8-3
F-HC5-08C28	3-2	F-PCT-02X16	2-8	HA-S-4MJ6FJ	8-5, 8-6	LA-102669	8-3
F-HC5-08C32	2-8	F-PCT-05X48	2-6, 4-2	HA-S-6FO8MO	8-5, 8-6	LA-102670	8-3

Model 2800 Hillco Leveling System
PART NUMBER INDEX (CONTINUED)

Part Number	Page	Part Number	Page	Part Number	Page
LA-133101	8-3, 8-4	LA-235471	7-4	LM-234231	2-2, 2-4
LA-133321	8-3, 8-4	LA-236731	7-2	LM-235481	3-2
LA-133331	8-3, 8-4	LA-238131	6-2	LP-103871	3-2
LA-133341	8-3, 8-4	LL-133731	9-2	LP-104791	2-2
LA-133351	8-3, 8-4	LL-133741	9-2	LP-117921	6-2
LA-133371	8-4	LL20-100773	9-2	LP-213301	2-2
LA-133381	8-4	LL20-100782	9-2	LP-227281	3-2
LA-133391	8-4	LL20-100783	9-2	MC-100168	9-2
LA-133401	8-4	LL20-100784	9-2	MC-100237	2-2, 2-4
LA-133421	8-4	LL20-100785	9-2	MC-100239	2-2, 2-4
LA-133431	8-4	LL20-100786	9-2	MC-100240	2-2, 2-4
LA-133441	8-4	LL20-100787	9-2	MC-100546	2-2, 2-4
LA-133451	8-4	LL20-100788	9-2	MC-100548	2-2, 2-4
LA-133461	8-4	LL20-100790	3-2	MC-100636	2-6
LA-133471	8-4	LL20-101868	7-2	MC-100637	2-6
LA-133481	8-4	LL20-101869	7-2	MC-100638	2-6
LA-133491	8-4	LM-206841	3-2, 8-5	MC-100639	2-6
LA-133501	8-4	LM-206851	3-2, 8-5	MC-100640	2-6
LA-133511	8-4	LM-207011	2-2, 2-4	MC-100700	5-2
LA-133521	8-4	LM-207631	7-2	MC-100710	6-2
LA-133751	8-4	LM-207801	2-2	MC-100758	4-2
LA-133761	8-4	LM-212561	5-2	MC-100760	2-2, 2-4
LA-206021	7-2	LM-212661	2-2	MC-100762	2-2, 2-4
LA-206031	7-2	LM-212701	2-2, 2-4	MC-100764	8-2
LA-212901	2-2, 2-4	LM-213202	2-2	MC-100768	9-2
LA-214931	6-2	LM-213241	2-2, 2-4	MC-101332	2-2, 2-4
LA-214981	6-2	LM-213251	2-2, 2-4	MC-101333	2-2, 2-4
LA-217691	3-2	LM-213261	2-2	MC-101336	2-2, 2-4
LA-217741	2-2, 2-4	LM-213291	2-2	MC-101339	2-2, 2-4
LA-219511	6-2	LM-214941	6-2	MC-101342	9-2
LA-220631	2-6	LM-214951	6-2	MC-101343	9-2
LA-220641	2-6	LM-218371	2-2	MC-101838	2-2, 2-4
LA-220651	2-6	LM-218501	2-6	MC-102152	2-2, 2-4
LA-220661	2-6	LM-219501	7-2	MC-102153	2-2, 2-4, 2-6
LA-225401	2-2	LM-219801	2-2, 2-4	MC-133711	5-2
LA-225411	2-2	LM-221591	2-2, 2-4		
LA-225551	2-2	LM-221602	2-2		
LA-225751	3-2	LM-225311	2-2		
LA-225951	3-2	LM-225321	2-2		
LA-226101	4-2	LM-225521	2-2		
LA-226851	2-2	LM-225531	2-2		
LA-226901	5-2	LM-225541	2-2		
LA-226971	6-2	LM-226061	4-2		
LA-226991	4-2	LM-226111	3-2		
LA-227001	6-2	LM-226531	2-2, 2-4, 2-6		
LA-227101	2-2	LM-226631	3-2		
LA-227242	3-2	LM-226831	2-2		
LA-227252	3-2	LM-226841	2-2		
LA-227262	3-2	LM-226961	2-6		
LA-228761	4-2	LM-227271	3-2		
LA-229071	2-2, 3-2	LM-229491	7-2		
LA-230551	3-2	LM-229501	7-2		
LA-234191	2-2, 2-4	LM-230501	7-2		
LA-234251	2-2, 2-4	LM-230811	6-2		
LA-235121	7-4	LM-230821	6-2		
LA-235131	7-4	LM-232161	2-2, 2-4		
LA-235141	7-4	LM-234151	2-2, 2-4		
LA-235151	7-4	LM-234161	2-2, 2-4		
LA-235161	7-4	LM-234221	2-2, 2-4		

Model 2800 Hillco Leveling System
PART NUMBER CROSS REFERENCE

MODEL 2800 PART NUMBER CROSS REFERENCE							
OLD PN	NEW PN		OLD PN	NEW PN		OLD PN	NEW PN
L20A-101290	LA-212901		L26A-102700	LA-227001		MFL20-101792	LP-117921
L20A-101348	LA-213481		L28A-102595	LA-225951		MFL20-102159	LM-221591
L20A-101493	LA-214931		L28A-102610	LA-226101		MFL20-102160	LM-221601
L20A-101498	LA-214981		L28A-102633	LA-102633		MFL26-101845	LM-229501
L20A-101775	LA-217751		L28A-102634	LA-102634		MFL26-101847	LM-229491
L20A-101951	LA-219511		L28A-102635	LA-102635		MFL26-101850	LM-218501
L20A-102697	LA-226971		L28A-102636	LA-102636		MFL26-101850	LM-218501
L26A-101768	LA-217681		L28A-102638	LA-102638		MFL26-101950	LM-219501
L26A-101769	LA-217691		L28A-102639	LA-102639		MFL26-102531	LM-225311
L26A-101774	LA-217741		L28A-102640	LA-102640		MFL26-102532	LM-225321
L26A-101797	LA-101797		L28A-102660	LA-226601		MFL26-102552	LM-225521
L26A-101798	LA-101798		L28A-102669	LA-102669		MFL26-102553	LM-225531
L26A-101799	LA-101799		L28A-102670	LA-102670		MFL26-102554	LM-225541
L26A-101800	LA-101800		L28A-102709	LA-230551		MFL26-102606	LM-226061
L26A-101803	LA-101803		L28A-102710	LA-227101		MFL26-102611	LM-226111
L26A-101804	LA-101804		L28A-102712	LA-229071		MFL26-102653	LM-226531
L26A-101808	LA-101808		L28A-102716	LA-227161		MFL26-102683	LM-226831
L26A-101809	LA-101809		L28A-102724	LA-227241		MFL26-102684	LM-226841
L26A-102063	LA-220631		L28A-102725	LA-227251		MFL26-102688	LM-234101
L26A-102064	LA-220641		L28A-102726	LA-227261		MFL26-102696	LM-226961
L26A-102064	LA-220641		L28A-102738	LA-227381		MFL26-102696	LM-226961
L26A-102065	LA-220651		L28A-102739	LA-227391		MFL28-102663	LM-226631
L26A-102065	LA-220651		LM-10305001	LM-230501		MFL28-102736	LM-227361
L26A-102066	LA-220661		MFCC-100684	LM-206841		MFLCC-100387	LP-103871
L26A-102540	LA-225401		MFCC-100685	LM-206851		MFLCC-100479	LP-104791
L26A-102541	LA-225411		MFL20-100701	LM-207011		MFLCC-101266	LM-212661
L26A-102555	LA-225551		MFL20-100763	LM-207631		MFLCC-101270	LM-212701
L26A-102558	LA-225581		MFL20-100780	LM-207801		MFLCC-101494	LP-214941
L26A-102575	LA-225751		MFL20-101256	LM-212561		MFLCC-101837	LM-218371
L26A-102602	LA-226021		MFL20-101320	LM-213201		MFLCC-101980	LM-219801
L26A-102609	LA-226091		MFL20-101324	LM-213241			
L26A-102685	LA-226851		MFL20-101325	LM-213251			
L26A-102687	LA-228761		MFL20-101326	LM-213261			
L26A-102690	LA-226901		MFL20-101329	LM-213291			
L26A-102699	LA-226991		MFL20-101495	LM-214951			