

Model 2960
Hillside Leveling System
Parts Manual
SN 2960-1201 thru 2960-1299
D-070522ADL01A





HILLCO
TECHNOLOGIES

2960 Hillside Leveling System
for 9600, 9610, and 9650 John Deere Combines

TABLE OF CONTENTS

1 GENERAL INFORMATION	1-3
Serial Number Location.....	1-3
Text Format and Illustrations.....	1-3
Abbreviations.....	1-3
Right and Left Identification.....	1-3
Parts Orders.....	1-3
2 TRANSITION	2-1
Transition Fasteners.....	2-3
Radial Pin Slip Clutch.....	2-5
3 CARRIAGE	3-1
Carriage Fasteners.....	3-3
4 Y-BRACE	4-1
5 DROP AXLE	5-1
6 LADDER	6-1
7 ELECTRICAL COMPONENTS	7-1
Electrical Connectors.....	7-3
Electrical Cables.....	7-5
8 HYDRAULICS	8-1
Hydraulic Manifold.....	8-3
Hydraulic Pump.....	8-5
Header Tilt Valve.....	8-7
Hydraulic Hoses.....	8-9
Hydraulic Hoses (Continued).....	8-10
Hydraulic Adapters.....	8-11
9 MISCELLANEOUS	9-1
10 PART NUMBER INDEX	10-1
Part Number Index (Continued).....	10-2

Model 2960 Hillco Leveling System
For Serial Number 2960-1201 thru 2960-1299

Hillco Technologies, Inc.
107 1st Avenue
Nezperce Id. 83543

Fax	208.937.2280
Phone	208.937.2461
Toll Free	800.937.2461

www.hillcotechnologies.com

1 GENERAL INFORMATION

SERIAL NUMBER LOCATION

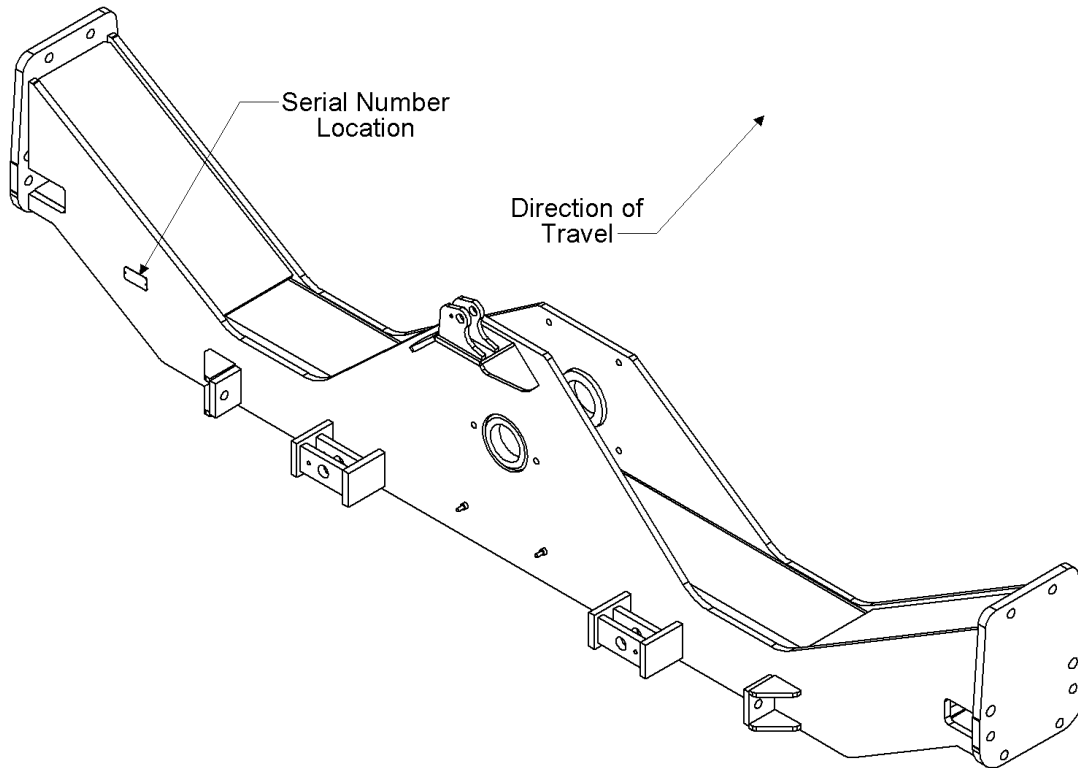

TEXT FORMAT AND ILLUSTRATIONS

The arrangement of this parts catalog is for easy identification of parts. All parts are illustrated in exploded views in proper relation to each other. Some diagrams refer to other pages for further information. Reference numbers used in the illustrations refer to line numbers in the part lists. The part lists appear to the right of all diagrams and correspond with those diagrams. Included in the part lists, along with the reference numbers are part numbers, part descriptions and the quantity of the part required per leveling system.

ABBREVIATIONS

SN "Serial Number" refers to the serial number given to each leveling system (by Hillco Technologies), as well as the serial number given to the combine (by the specific combine manufacturer) the leveling system is installed upon. This abbreviation is used interchangeably in both instances. Each model 2960 Leveling System uses the following serial number format: 2960-XXXX (sequential numbers).

ASM "Assembly" refers to a whole grouping of parts (usually shown in the diagram corresponding with the page where "ASM" is shown unless otherwise noted). Some assemblies have parts that are sold separately, however some must be purchased as a single unit. Hillco Product Specialists will be able to assist you with any questions.

NS "Not Shown" refers to a part that is not depicted in the illustration.

RIGHT AND LEFT IDENTIFICATION

The reference to right-hand and left-hand in this catalog is identified by the operator sitting in the operator's seat, looking toward the front of the machine (in normal forward travel).

PARTS ORDERS

Orders must specify product model, serial number, correct part number, complete description, quantity required, method of shipment, shipping address, and billing address.

2 TRANSITION

SEE PAGE 2-3 FOR
TRANSITION FASTENERS

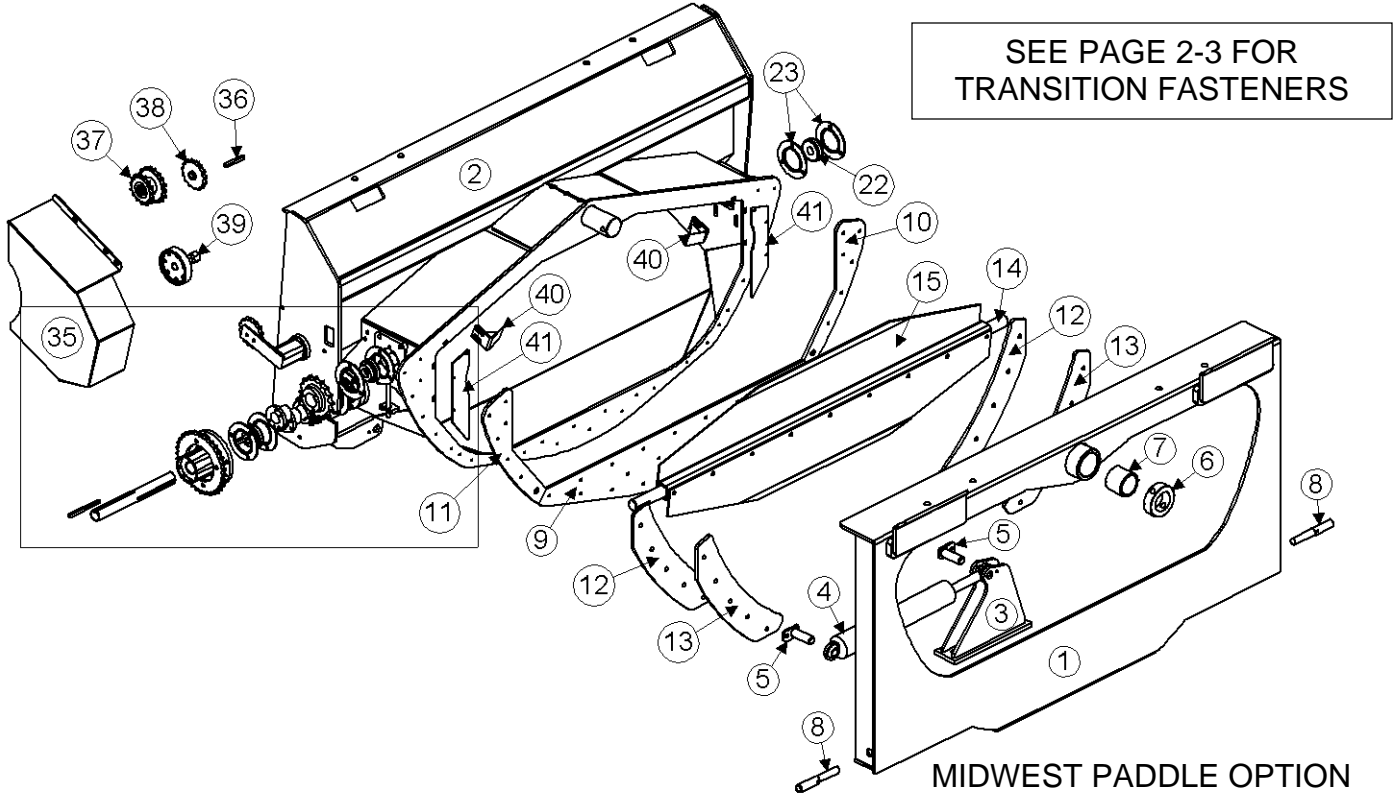

MIDWEST PADDLE OPTION

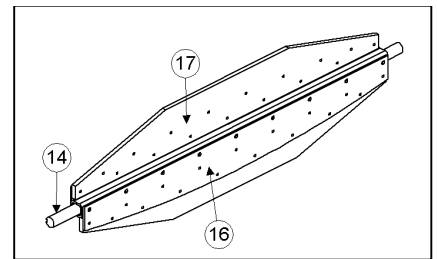

TRANSITION DRIVE COMPONENT DETAIL

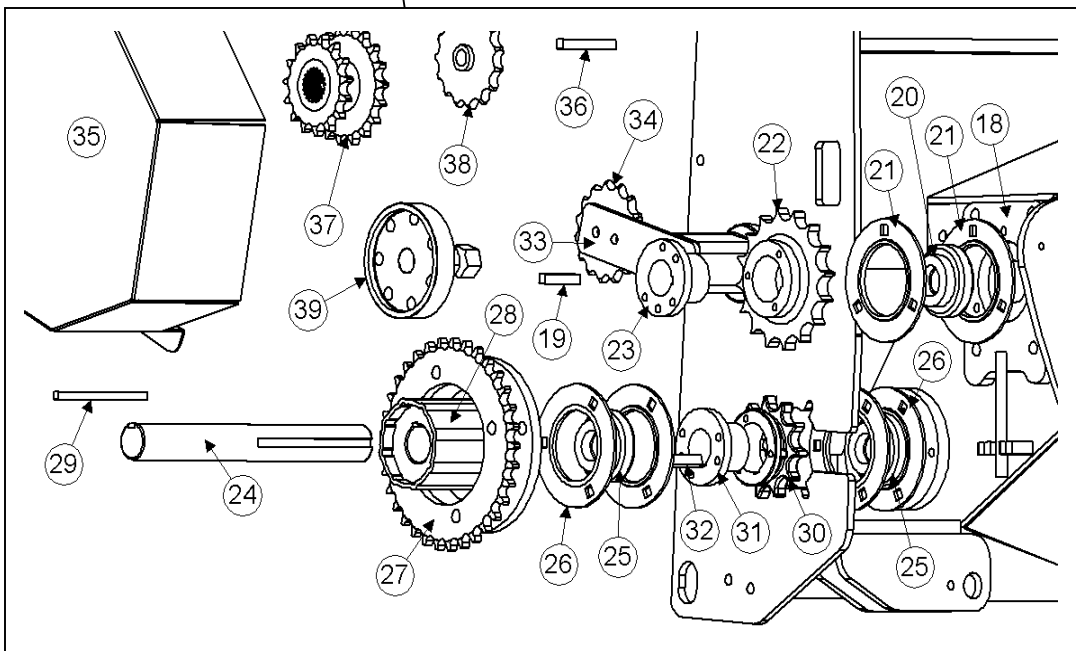

Model 2960 Hillco Leveling System
For Serial Number 2960-1201 thru 2960-1299

TRANSITION				
REF.	PART NO.	QTY.	PART NAME	NOTES
1	LA-228893	1	TA ADAPTER ASM	
2	LA-234952	1	TT THROAT ASM	
3	LA-229022	1	TM MOUNT ASM, ROD	
4	HC-100706	1	CYLINDER, SLAVE	SEE HYDRAULICS PAGE
NS	HC-134191	1	SEAL KIT, SLAVE CYLINDER	
5	LA-229071	2	TM PIN ASM, TRIM CYLINDER	
6	LM-226841	1	TM COLLAR, PIVOT	
7	LTP-241721	1	BUSHING, GRAPHITE	
8	LM-229192	2	TM ROD, LOCK	
NS	MC-135531	2	SPRING, COMPRESSION	
9	LM-229152	1	TM PLATE, WEAR BOTTOM	
10	LM-229161	1	TM PLATE, WEAR LH	
11	LM-229171	1	TM PLATE, WEAR RH	
12	LM-249861	2	TM PLT, BACKING	
13	LP-249871	2	TM UHMW, BACKING	
BEATER SHAFT				
14	LA-249611	1	TB ASM, SHAFT	
15	LM-238341	2	TB PADDLE, METAL	
16	LM-228442	2	TB PLATE, PADDLE BACKING	OPTIONAL
17	LP-228881	2	TB PADDLE, RUBBER	OPTIONAL
18	LA-229051	2	TM MOUNT ASM, BEATER	
19	LS-212701	1	TM KEY, BEATER DRIVE	
20	MC-100548	2	BEARING INSERT, 1-7/16, NON-RELUBE	
21	MC-101339	2	FLANGETTES, RND BEARING (PAIR)	
22	MC-135501	1	SPROCKET, 16T 80P TAPER BORE HRD	
23	MC-135511	1	HUB, SPLIT TAPER 1-7/16	
NS	LP-232162	1	TM CHAIN, 28 PIN 80P	
NS	MC-139341	1	LINK, CONNECTING, 80P	
NS	MC-139351	1	LINK, OFFSET, 80P	
TRANSITION THROAT JACK SHAFT				
24	LM-229142	1	TM SHAFT, JACK	
25	MC-100548	2	BEARING INSERT, 1-7/16, NON-RELUBE	
26	MC-101339	2	FLANGETTES, RND BEARING (PAIR)	
27	LM-226532	1	TM SPROCKET, RADIAL SLIP CLUTCH	SEE RADIAL PIN SLIP CLUTCH PAGE
28	MC-136921	1	RADIAL PIN SLIP CLUTCH	
29	LS-244471	1	TM KEY, RADIAL PIN SLIP CLUTCH	
30	MC-135491	1	SPROCKET, 11T 80P TAPER BORE HRD	
31	MC-135511	1	HUB, SPLIT TAPER 1-7/16	
32	LS-212701	1	TM KEY, BEATER DRIVE	
NS	LP-255131	1	TM CHAIN, 72 PIN 60P	
NS	MC-139361	1	LINK, CONNECTING, 60P	
NS	MC-139371	1	LINK, OFFSET, 60P	
TENSIONER				
33	MC-100546	1	TENSIONER	
34	MC-100237	1	SPROCKET, IDLER, 15T60P5/8B	
NS	MC-139241	1	TENSIONER HARDWARE KIT	
FEEDER HOUSE BEATER DRIVE				
35	LM-236232	1	TM SHIELD, DRIVE	
NS	LP-232162	1	TM ROLLER CHAIN, 28 PIN 80P	
36	LS-234241	1	TM KEY, FEEDER SHAFT	
NS	LM-254781	1	LM FLAT, CM BAR	
FOR 9650 & 9660 COMBINES				
37	LA-263171	1	TM ASM, DRIVE SPROCKET	
FOR 9600 & 9610 COMBINES				
38	MC-103113	2	SPROCKET, 15T 60P 1-1/2B HRD3/8K	
39	LTA-242191	1	LTM ASM, HEX DRIVE ADAPTOR	
NS	MC-142001	2	1PC SPLIT COLLAR WITH 1-3/8 BORE	
OPTIONAL - FOR COMBINES HARVESTING LEGUMES (PEAS, LENTILS, GARBONZO BEANS, FLAX)				
40	LA-260051	2	TM ASM, ANTI-WRAP	
41	LM-260041	2	TM PLATE, NARROWING	
NS	LA-243121	1	TRANSITION THROAT NARROWING KIT	

Model 2960 Hillco Leveling System
For Serial Number 2960-1201 thru 2960-1299

TRANSITION FASTENERS

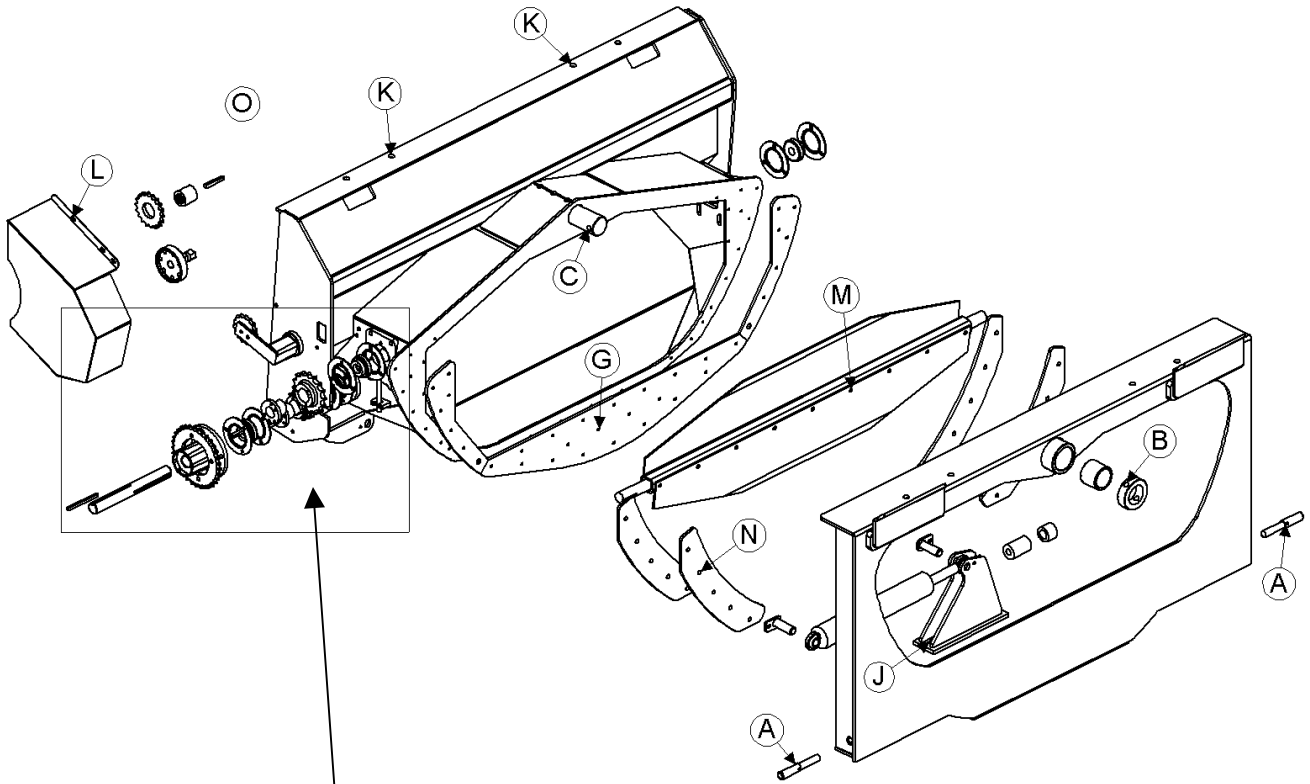

MIDWEST PADDLE OPTION

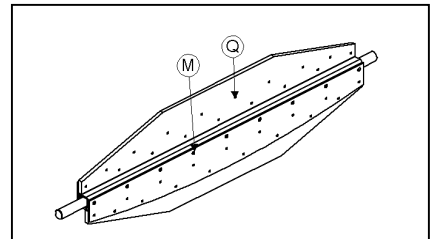

TRANSITION FASTENERS DRIVE COMPONENT DETAIL

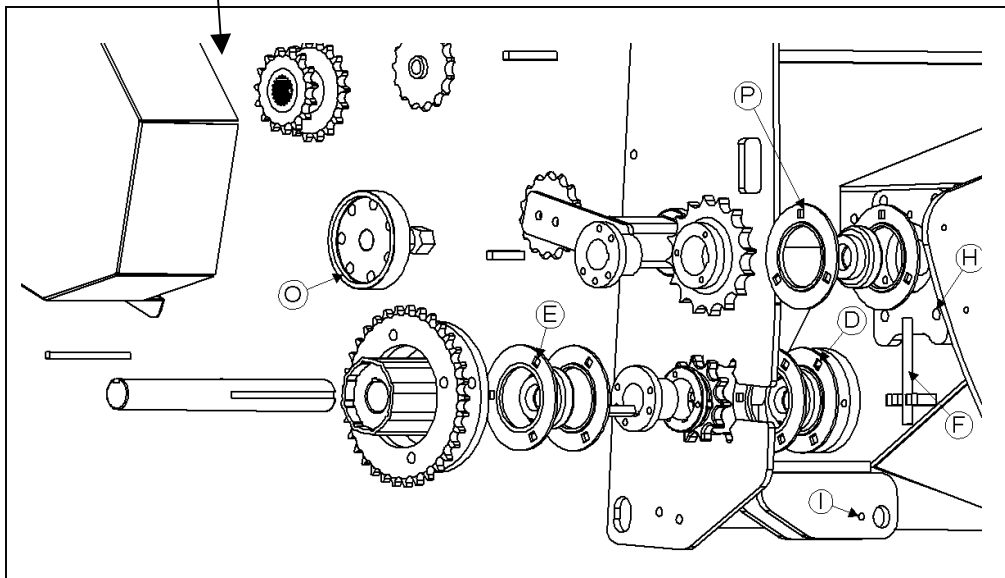

Model 2960 Hillco Leveling System
For Serial Number 2960-1201 thru 2960-1299

TRANSITION FASTENERS				
ASM	PART NO.	QTY.	PART NAME	WHERE USED
A	F-SHC-10M070F	2	SHCS-8.8 M10 X 1.50 X 70	THA HEADER LOCK
B	F-HC-16M120E	1	HC-10.9 M16 X 2.00 X 120	MAIN PIVOT PIN COLLAR
B	F-HNS-16ME	1	HN-10.9 M16 X 2.00 STV	MAIN PIVOT PIN COLLAR
C	F-MB-14NR40	3	MACH BUSH 14 GA NR 2-1/2" ID	MAIN PIVOT PIN
D	F-HCF-10M020E	3	FLHC-10.9 M10 X 1.50 X 20	INNER 3-BOLT JS BEARING
E	F-CB-10M030F	3	CARR-8.8 M10 X 1.50 X 30	OUTER 3-BOLT JS BEARING
E	F-HNF-10MF	3	FLHN-8.8 M10 X 1.50	OUTER 3-BOLT JS BEARING
F	F-FWH-08	4	FW 1/2 HD YELLOW	BEATER BRNG TAKE-UP BLT
F	F-HNJ-12MF	4	HN-8.8 M12 X 1.75 JAM	BEATER BRNG TAKE-UP BLT
G	F-FHS-8M015E	29	FHSC-10.9 M8 X 1.25 X 15	TT FACE PLATE
H	F-CB-12M040F	8	CARR-8.8 M12 X 1.75 X 40	TT BEATER BRNG MNT PLT
H	F-HNF-12MF	8	FLHN-8.8 M12 X 1.75	TT BEATER BRNG MNT PLT
I	F-HCF-10M020F	2	FLHC-8.8 M10 X 1.50 X 20	SLAVE CYL MNT PIN
J	F-HC-16M050E	3	HC-10.9 M16 X 2.00 X 50	ROD MNT
J	F-HNS-16ME	3	HN-10.9 M16 X 2.00 STV	ROD MNT
K	F-HCF-12M040E	4	FLHC-10.9 M12 X 1.75 X 40	TRANSITION MNT
K	F-HCF-16M040E	4	FLHC-10.9 M16 X 2.00 X 40	TRANSITION MNT
L	F-HNF-10MF	2	FLHN-8.8 M10 X 1.50	TM DRIVE SHIELD
L	F-HCF-10M020F	2	FLHC-8.8 M10 X 1.50 X 20	TM DRIVE SHIELD
M	F-HNSF-12ME	9	FLHN-10.9 M12 X 1.75 FLNG, STV	BEATER PADDLES
M	F-HCF-12M080E	9	FLHC-10.9 M12 X 1.75 X 80	BEATER PADDLES
N	F-HCF-12M040E	10	FLHC-10.9 M12 X 1.75 X 40	BACKING PLATES
O	F-HC-12M050E	7	HC-10.9 M12 X 1.75 X 50	FEEDER HOUSE HEX DRIVE SHAFT
O	F-HNS-12ME	7	HN-10.9 M12 X 1.75 STV	FEEDER HOUSE HEX DRIVE SHAFT
O	F-FWH-08	7	FW 1/2 HD	FEEDER HOUSE HEX DRIVE SHAFT
P	F-HCF-10M020F	6	FLHC-8.8 M10 X 1.50 X 20	TT BEATER BRNG MNT PLT
OPTIONAL FOR MIDWEST COMBINES				
Q	F-EB-04C20	34	BOLT, ELEVATOR, 1/4-20 x 1-1/4 ZINC	PB PADDLES
Q	F-HNF-04C	34	FLHN 1/4-20 ZINC, SERR	PB PADDLES
R	F-HCF-10M025E	4	FLHC- 10.9 M10 X 1.50 X 25	ANTI-WRAP ASSEMBLIES
R	F-HNF-10ME	4	FLHN- 10.9 M10 X 1.50	ANTI-WRAP ASSEMBLIES
S	F-HC-06M020F	6	HC- 8.8 M6 X 1.0 X 20	THROAT NARROWING PLATES
S	F-HNF-06MF	6	FLHN- 8.8 M6 X 1.0	THROAT NARROWING PLATES

Model 2960 Hillco Leveling System
For Serial Number 2960-1201 thru 2960-1299
RADIAL PIN SLIP CLUTCH

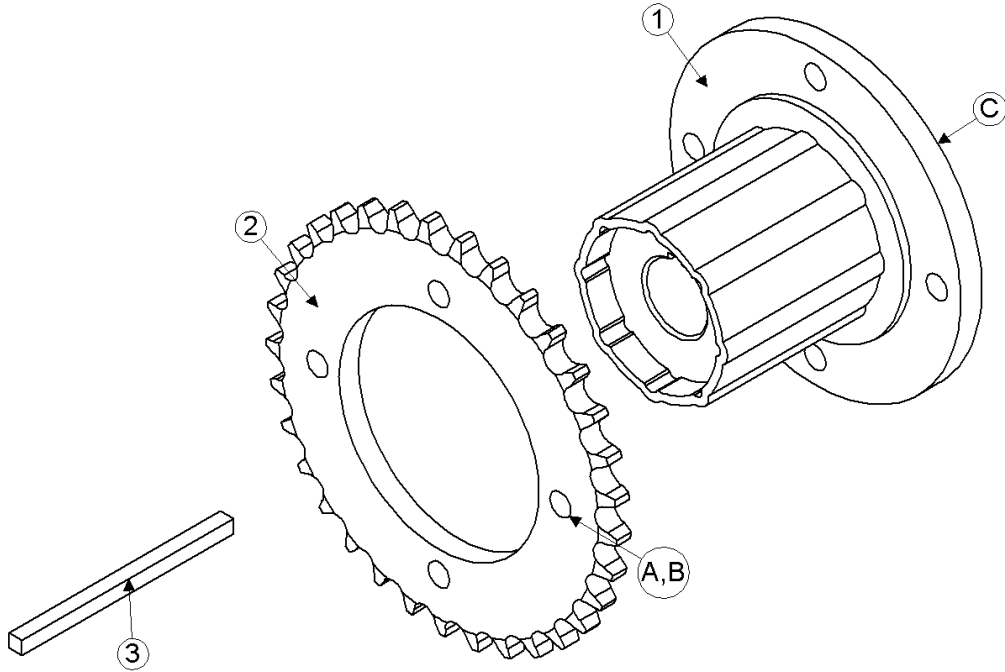

Model 2960 Hillco Leveling System
For Serial Number 2960-1201 thru 2960-1299

RADIAL PIN SLIP CLUTCH COMPONENTS				
REF.	PART NO.	QTY.	PART NAME	NOTES
1	LM-226532	1	TM SPROCKET, RADIAL SLIP CLUTCH	
2	MC-136921	1	RADIAL PIN SLIP CLUTCH	
3	LS-244471	1	TM KEY, RADIAL PIN SLIP CLUTCH	
RADIAL PIN SLIP CLUTCH FASTENERS				
REF.	PART NO.	QTY.	PART NAME	WHERE USED
A	F-HC8-08F20	4	HC8 1/2-20 X 1-1/4	
B	F-LW-08A	4	LW 1/2 HD	
C	F-SSS-06C08	2	SCREW, SOCKET SET 3/8-16 X 1/2	

3 CARRIAGE

SEE PAGE 3-3 FOR
CARRIAGE FASTENERS

FRONT VIEW

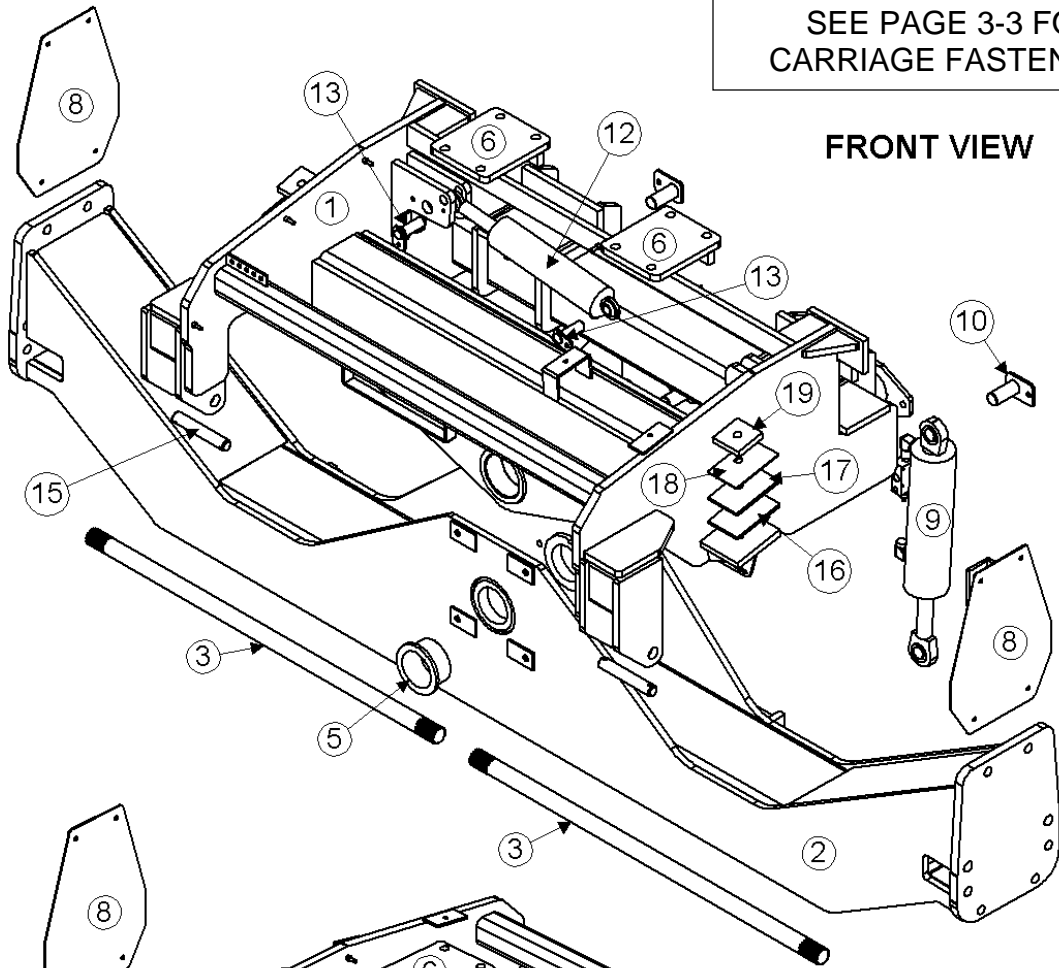

REAR VIEW

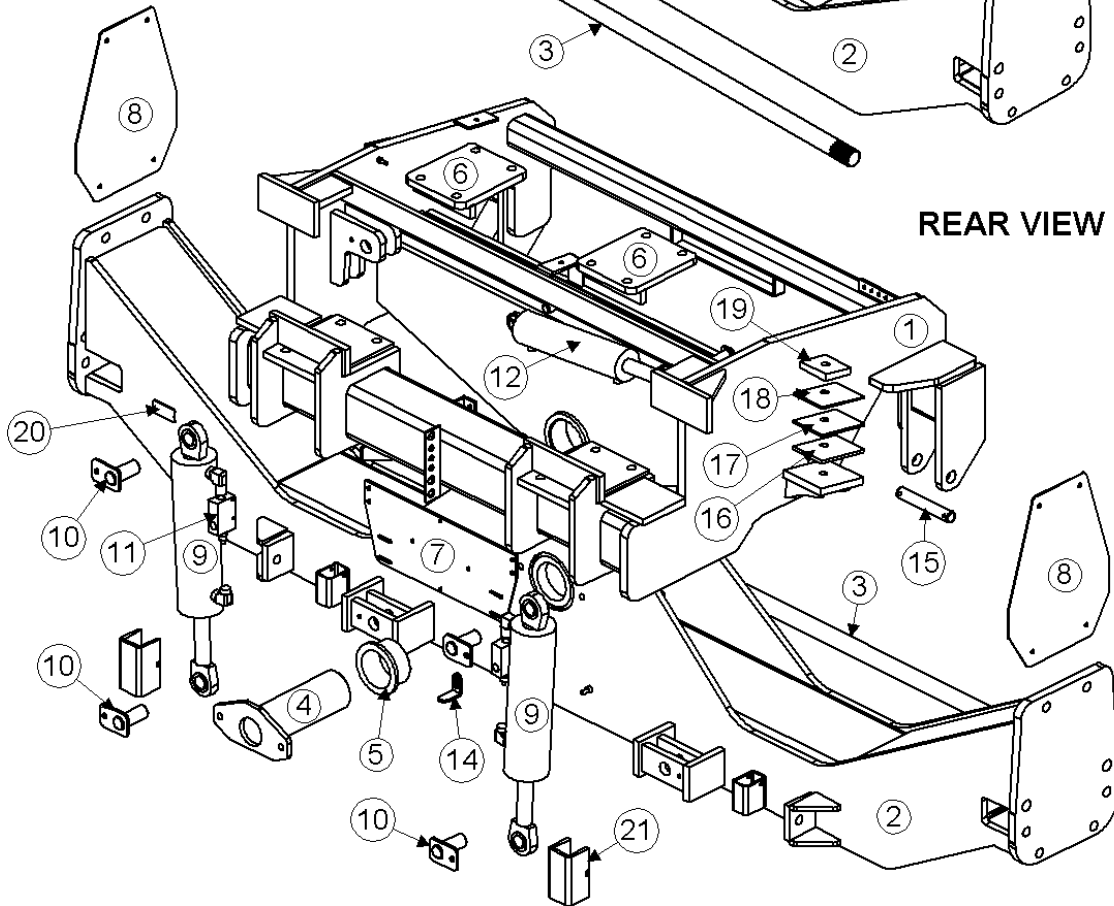

Model 2960 Hillco Leveling System
For Serial Number 2960-1201 thru 2960-1299

CARRIAGE COMPONENTS				
REF.	PART NO.	QTY.	PART NAME	NOTES
1	LA-228453	1	CO OVERCARRIAGE ASM	
2	LA-238271	1	CU ASM, 131.875	
3	MC-133081	2	COUNTER SHAFT, 1209 MM	
4	LA-229251	1	CM PIN ASM, MAIN PIVOT	
5	LP-103871	2	CO BUSHING, PIVOT	
6	LA-228681	2	CM PLATE ASM, AXLE BOLT	
7	LM-236473	1	EM PLATE, CONTROL BOX MOUNT	
8	LP-230241	2	CM CAP, AXLE	
9	HC-103228	2	CYLINDER, MAIN LEVELING	<i>SEE HYDRAULIC PAGE</i>
10	LA-230551	4	CM PIN ASM, MAIN CYLINDER	
11	HC-139151	2	VALVE, 3-PORT COUNTERBALANCE	<i>SEE HYDRAULIC PAGE</i>
12	HC-101842	1	CYLINDER, MASTER	<i>SEE HYDRAULIC PAGE</i>
13	LA-229071	2	TM PIN ASM, TRIM CYLINDER	
14	LP-234572	2	EM MOUNT, LIMIT SWITCH ACTUATOR	
15	LM-229483	2	CM PIN, HEADER LIFT	
16	LM-230621	2	CM SPACER, CO MOUNT 3/8	
17	LM-230611	2	CM SPACER, CO MOUNT 1/4	
18	LM-230641	2	CM SPACER, CO MOUNT 3/16	
19	LM-230631	2	CM PAD, CO MOUNT TOP	
20	LL20-100790	1	SERIAL NUMBER PLATE	
21	LP-249321	1	CM SPACER, SHIPPING	

Model 2960 Hillco Leveling System
For Serial Number 2960-1201 thru 2960-1299

CARRIAGE FASTENERS

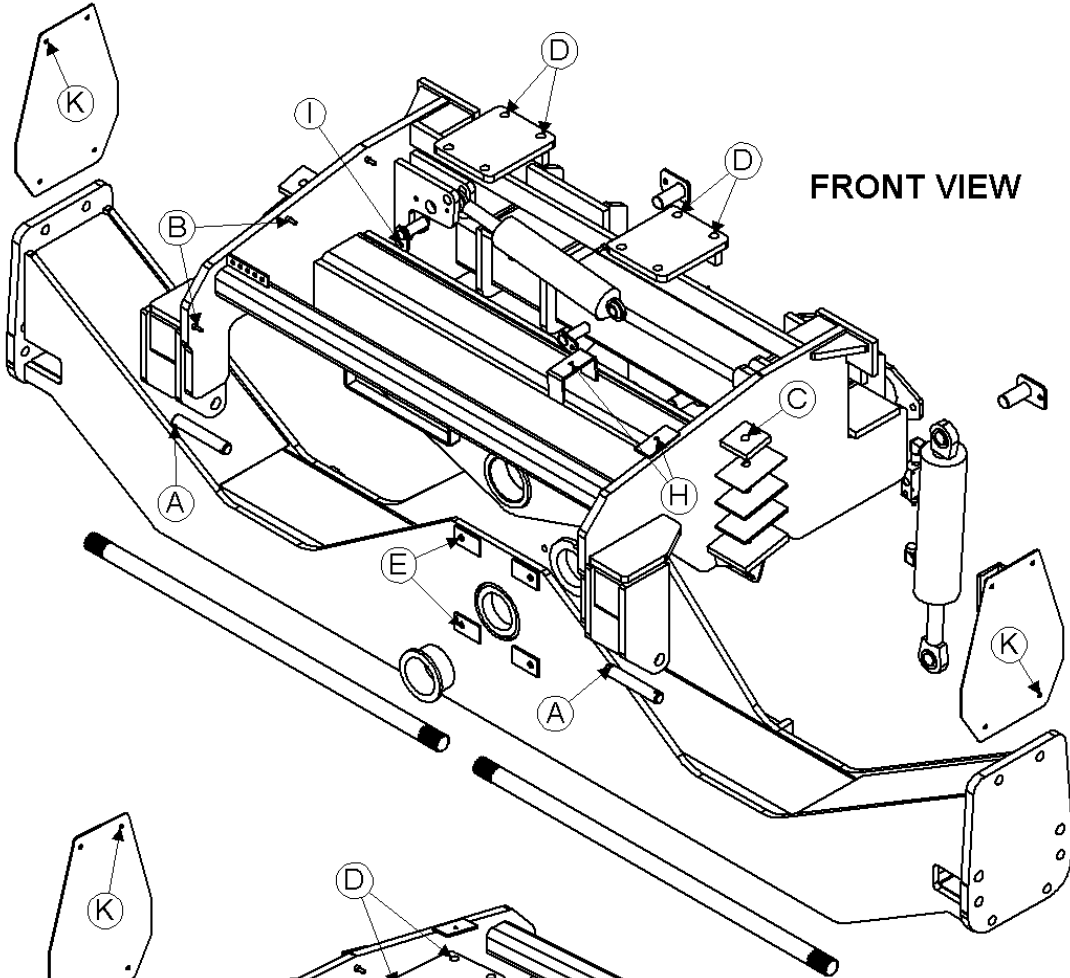

FRONT VIEW

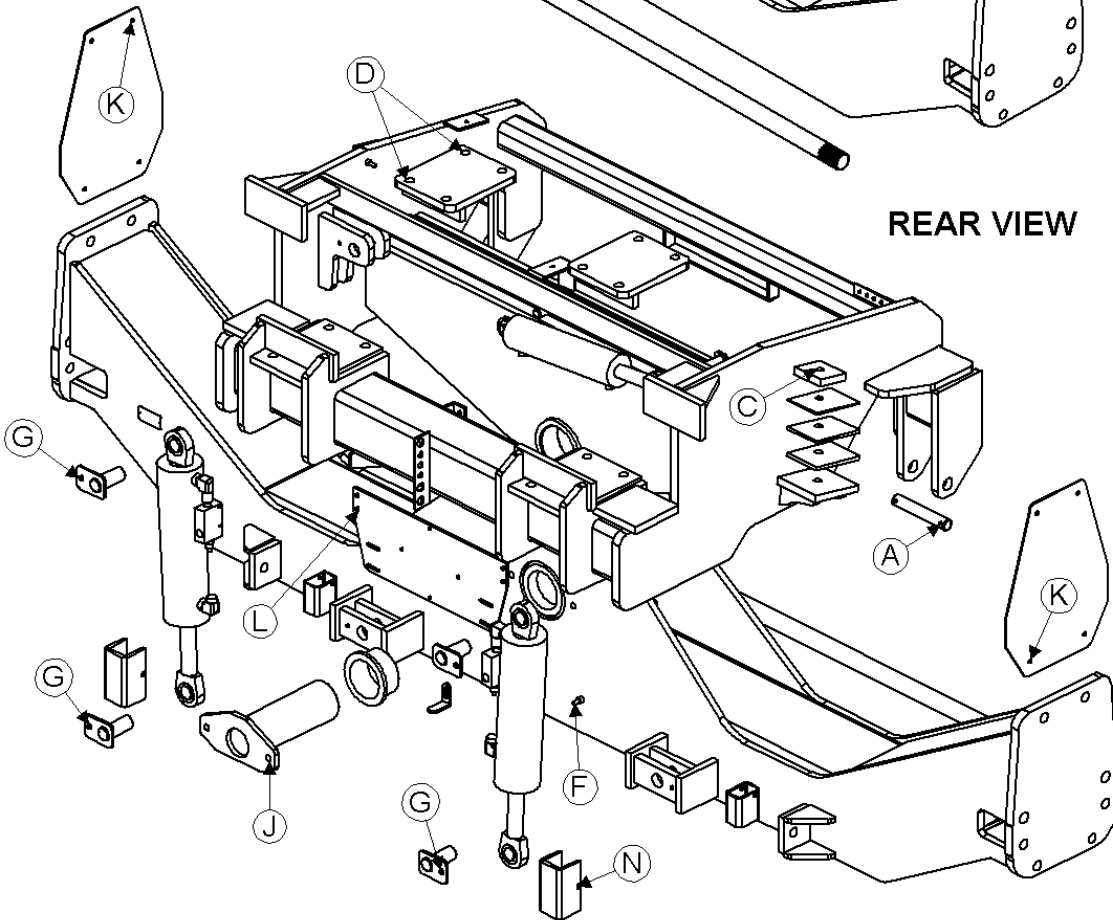

REAR VIEW

Model 2960 Hillco Leveling System
For Serial Number 2960-1201 thru 2960-1299

CARRIAGE FASTENERS				
REF.	PART NO.	QTY.	PART NAME	WHERE USED
A	F-PCT-05X48	4	COTTER PIN 5/16 X 3	BUTT END HEADER LIFT CYLINDER
A	F-MB-10NR20	4	MACH BUSH, 10 GA NR 1-1/4	BUTT END HEADER LIFT CYLINDER
B	F-HNF-08MF	7	FLHN-8.8 M8 X 1.25	HOSE CLAMPES
C	F-HC-16M180E	2	HC-10.9 M16 X 2.00 X 180	FRONT OVERCARRIAGE MOUNT
C	F-FWH-10	4	FW 5/8 HD	FRONT OVERCARRIAGE MOUNT
C	F-HNS-16ME	2	HN-10.9 M16 X 2.00 STV	FRONT OVERCARRIAGE MOUNT
D	F-HNS-12C	8	HN8 3/4-10 STV	REAR OVERCARRIAGE MOUNT
D	F-HC8-12C240	8	HC8 3/4-10 X 15	REAR OVERCARRIAGE MOUNT
E	F-HCF-16M080E	4	FLHC-10.9 M16 X 2.00 X 80	TRANSMISSION
F	F-HNF-10ME	2	FLHN-10.9 M10 X 1.50	LIMIT SWITCH ACTUATOR
G	F-HCF-12M025F	4	FLHC-8.8 M12 X 1.75 X 25	LEVELING CYL MNT PIN
H	F-HC-08M090F	2	HC-8.8 M8 X 1.25 X 90	BEHRINGER CLAMPS FOR HYDRO HOSES
H	F-HNF-08MF	2	FLHN-8.8 M8 X 1.25	BEHRINGER CLAMPS FOR HYDRO HOSES
I	F-HCF-10M020E	2	FLHC-10.9 M10 X 1.50 X 20	MASTER CYL MNT PIN
J	F-HC-16M060E	2	HC-10.9 M16 X 2.00 X 60	MAIN PVT PIN
J	F-HNS-16ME	2	HN-10.9 M16 X 2.00 STOVER	MAIN PVT PIN
K	F-HC-10M040F	8	HC-8.8 M10 X 1.50 X 40	ORIGINAL AXLE COVER
K	F-FWF-06020	8	3/8 FW FENDER X 1-1/4	ORIGINAL AXLE COVER
K	F-HNF-10MF	8	FLHN-8.8 M10 X 1.50	ORIGINAL AXLE COVER
L	F-HC-10M025F	4	HC-8.8 M10 X 1.50 X 25	CONTROL BOX MOUNT BRACKET
L	F-HNF-10MF	4	FLHN-8.8 M10 X 1.50	CONTROL BOX MOUNT BRACKET
M	F-UDS-#7X06	2	#7 X 3/8 U-DRIVE SCREW	SERIAL NUMBER PLATE
N	F-PSL-04X48	2	SNAP LOCK PIN 1/4 X 3	SAFETY STOPS

Model 2960 Hillco Leveling System
For Serial Number 2960-1201 thru 2960-1299

4 Y-BRACE

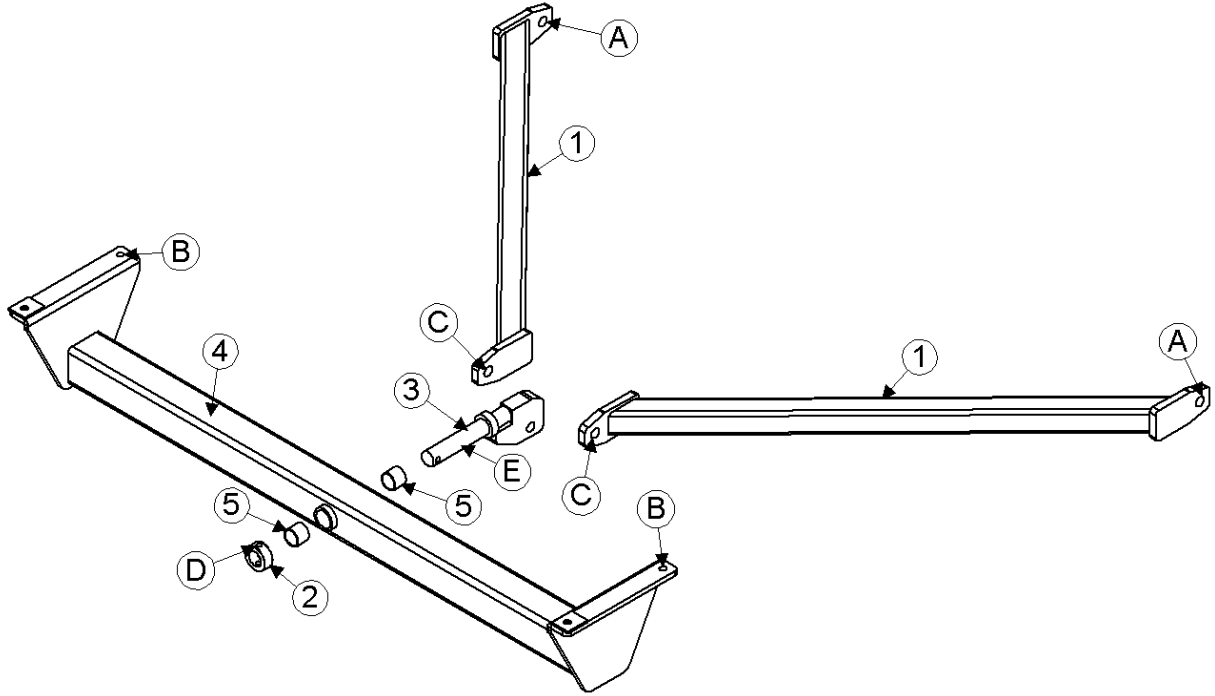

Model 2960 Hillco Leveling System
For Serial Number 2960-1201 thru 2960-1299

Y-BRACE COMPONENTS				
REF.	PART NO.	QTY.	PART NAME	NOTES
1	LA-228702	2	YB ARM ASM	
2	LM-234101	1	YB COLLAR, PIVOT PIN	
3	LA-228762	1	YB PIN ASM, PIVOT	
4	LA-228721	1	YB SUPPORT ASM, CROSS	
5	MC-135431	2	BUSHING, PLANE	
Y-BRACE FASTENERS				
REF.	PART NO.	QTY.	PART NAME	WHERE USED
A	F-HC-24M070E	2	HC-10.9 M24 X 3.00 X 70	Y-BRACE FRNT MNT
A	F-HNS-24ME	2	HN-10.9 M24 X 3.00 STOVER	Y-BRACE FRNT MNT
B	F-HC-16M140E	4	HC-10.9 M16 X 2.00 X 140	Y-BRACE FRAME MNT
B	F-HNS-16ME	4	HN-10.9 M16 X 2.00 STOVER	Y-BRACE FRAME MNT
B	F-FWH-10	8	FW 5/8 HD	Y-BRACE FRAME MNT
C	F-HC-24M110E	1	HC-10.9 M24 X 3.00 X 110	Y-BRACE REAR MNT
C	F-HNS-24ME	1	HN-10.9 M24 X 3.00 STOVER	Y-BRACE REAR MNT
D	F-HC-12M080E	1	HC-10.9 M12 X 1.75 X 80	Y-BRACE PVT PIN COLLAR
D	F-HNS-12ME	1	HN-10.9 M12 X 1.75 STOVER	Y-BRACE PVT PIN COLLAR
E	F-MB-18NR24	20	MACH BUSH 18 GA NR 1-1/2" ID	Y-BRACE PVT PIN

Model 2960 Hillco Leveling System
For Serial Number 2960-1201 thru 2960-1299

5 DROP AXLE

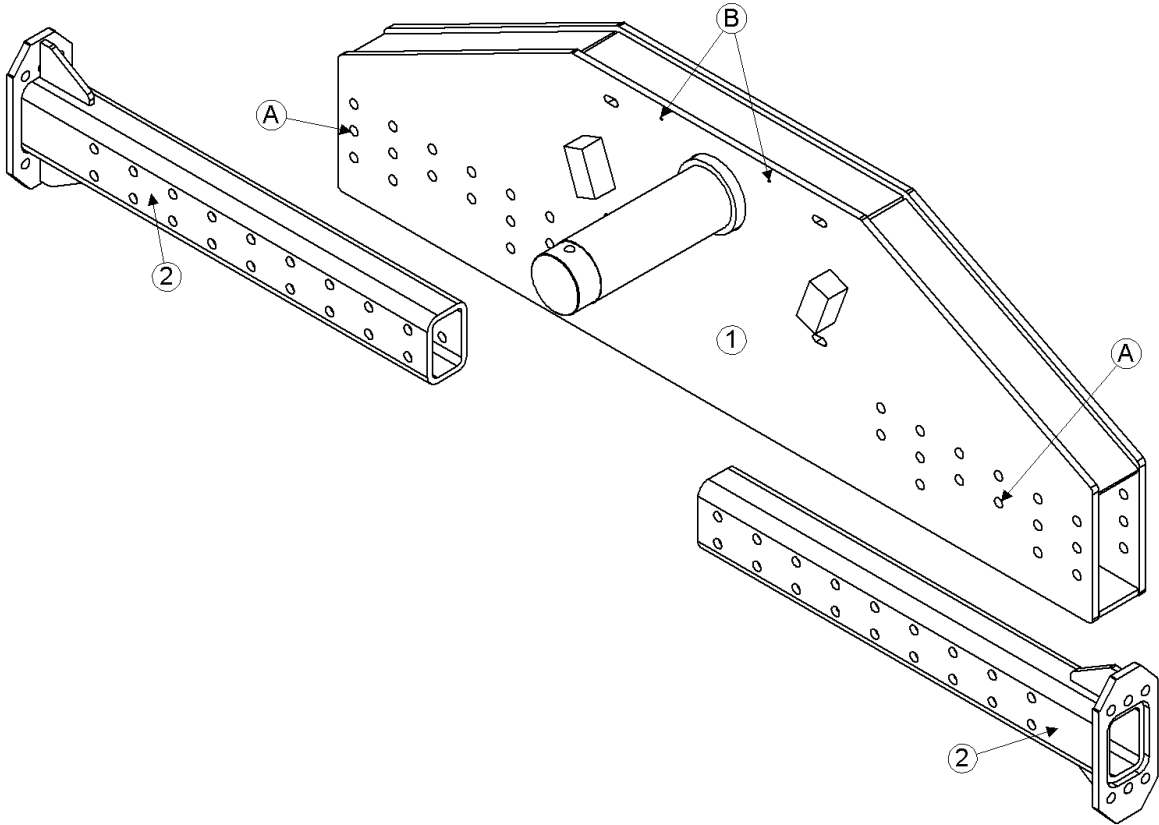

Model 2960 Hillco Leveling System
For Serial Number 2960-1201 thru 2960-1299

DROP AXLE COMPONENTS				
REF.	PART NO.	QTY.	PART NAME	NOTES
1	LA-228811	1	DA AXLE ASM, DROP	
2	LA-238881	2	DA ASM, EXTENSION	<i>OPTIONAL- IF COMBINE DIDN'T HAVE ADJUSTABLE REAR AXLE</i>
DROP AXLE FASTENERS				
REF.	PART NO.	QTY.	PART NAME	WHERE USED
A	F-HC-20M160E	8	HC-10.9 M20 X 2.50 X 160	
A	F-HC-20M210E	4	HC-10.9 M20 X 2.50 X 210	STEERING CYLINDER MOUNT
A	F-HNS-20ME	12	HN-10.9 M20 X 2.50 STV	
B	F-HCF-06M045F	2	FLHC-8.8 M6 X 1.00 X 45	

6 LADDER

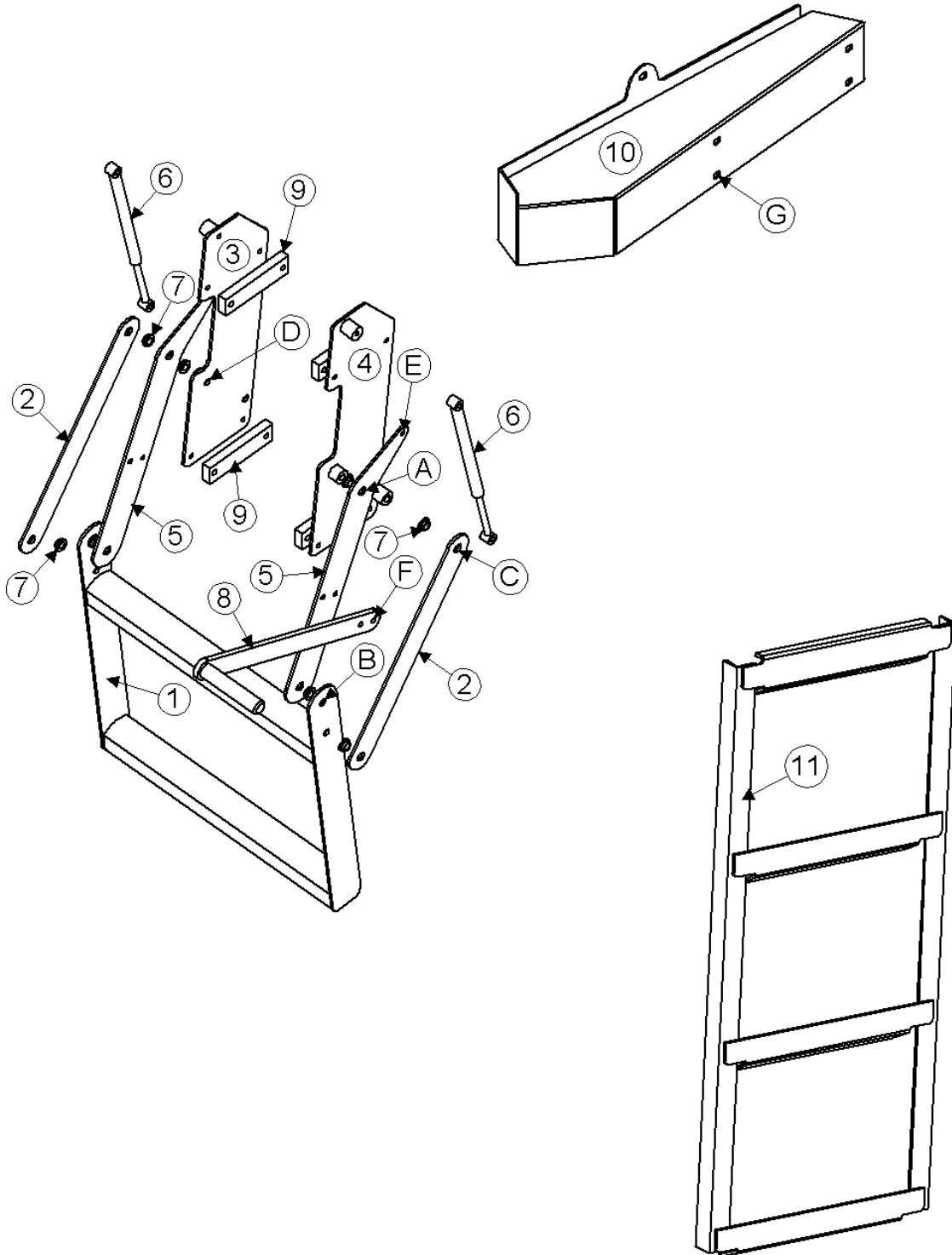

Model 2960 Hillco Leveling System
For Serial Number 2960-1201 thru 2960-1299

LADDER COMPONENTS				
REF.	PART NO.	QTY.	PART NAME	DESCRIPTION
1	LA-236563	1	LM ASM, LOWER STEP ASM	
2	LM-236053	2	LM PLT, MID ARM (FOLDING LADDER LINK)	
3	LA-236542	1	LM PLT ASM, LFT SIDE FOLDING LADDER	
4	LA-236552	1	LM PLT ASM, RHT SIDE FOLDING LADDER	
5	LM-236632	2	LM PLT, UPPER ARM	
6	MC-134921	2	LIFT SUPPORT, GAS CHARGED	
NS	MC-134931	2	BRACKETS, LIFT SUPPORT (PAIR)	
7	MC-134941	8	BUSHING, FLANGED OILITE	
8	LA-238761	1	LM ASM, LADDER HANDLE	
9	LM-241271	4	LM FLT, LADDER SPACER	
10	LA-240161	1	LM ASM, LDR WEDGE	
11	LA-238691	1	LM ASM, REAR LADDER	
LADDER FASTENERS				
REF.	PART NO.	QTY.	PART NAME	WHERE USED
A	F-HC-12M050E	2	HC-8.8 M12 X 1.75 X 50	TOP SIDE PLATE PIVOT
A	F-HNS-12ME	2	HN-10.9 M12 X 1.75 STV	PIVOTS
B	F-HC-12M030F	4	HC-8.8 M12 X 1.75 X 30	MIDDLE PIVOTS
B	F-HNS-12ME	4	HN-10.9 M12 X 1.75 STV	PIVOTS
C	F-HC-12M065F	2	HC-8.8 M12 X 1.75 X 65	BOTTOM SIDE PLT PIVOTS
C	F-HNS-12ME	2	HN-10.9 M12 X 1.75 STV	PIVOTS
D	F-HC-08M035F	8	HC-8.8 M8 X 1.25 X 35	SIDE PLATE MOUNTS
D	F-HNF-08MF	8	FLHN 8.8 M8 X 1.25	SIDE PLATE MOUNTS
E	F-HNJ-05C	2	HN5 5/16-18 JAM NUT	BALL STUD
E	F-LW-05	4	LW 5/16	BALL STUD
F	F-HC-08M025F	2	HC-8.8 M8 X 1.25 X 25	HANDLE
F	F-HNF-08MF	2	FLHN 8.8 M8 X 1.25	HANDLE
G	F-HCF-10M025F	4	FLHC-8.8 M10 X 1.50 X 25	WEDGE
G	F-HNF-10MF	4	FLHN-8.8 M10 X 1.50	WEDGE

7 ELECTRICAL COMPONENTS

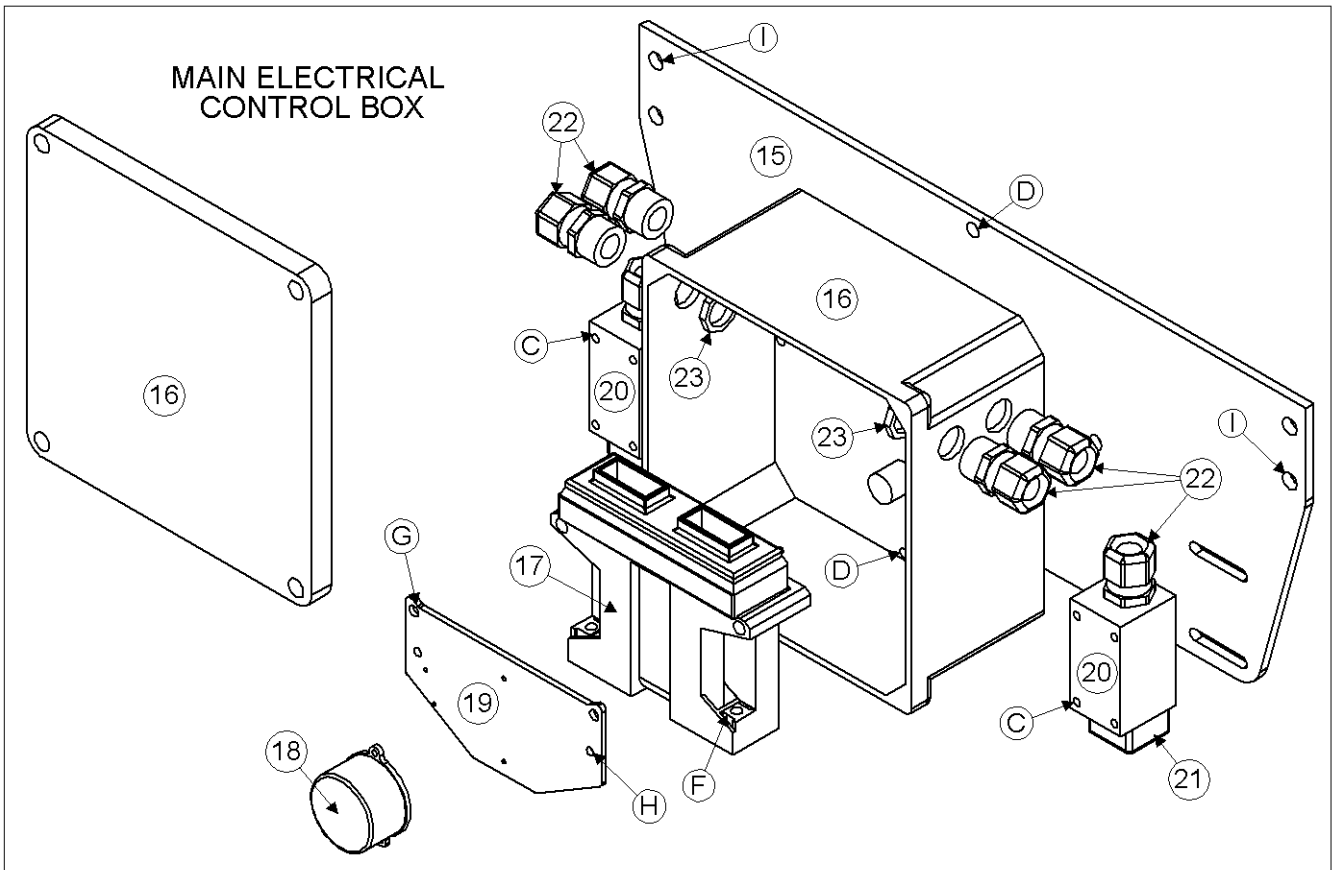
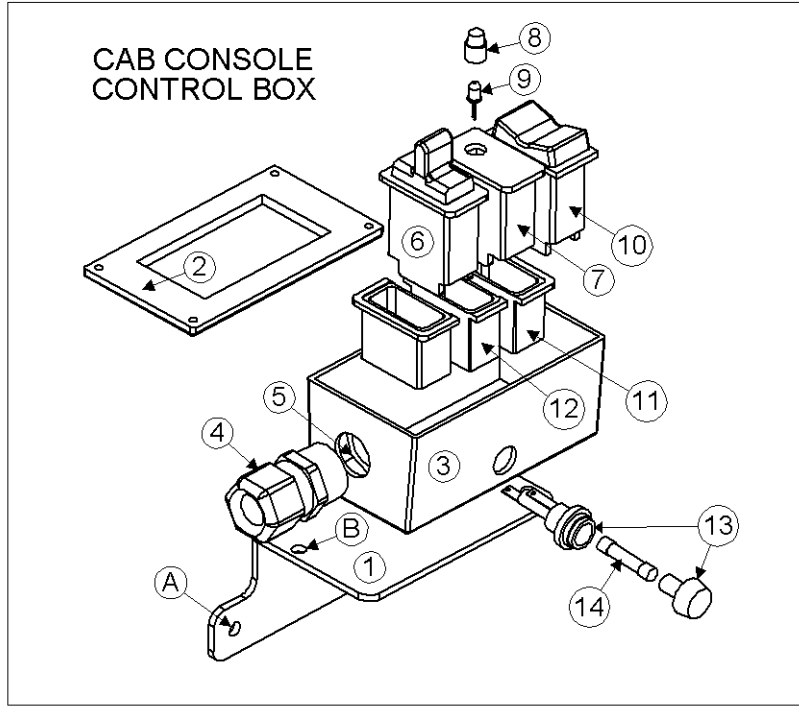

Model 2960 Hillco Leveling System
For Serial Number 2960-1201 thru 2960-1299

CAB CONSOLE CONTROL BOX COMPONENTS				
9600 AND 9610 COMBINES ONLY				
REF.	PART NO.	QTY.	PART NAME	NOTES
ASM	LA-257351	1	EM ASM, CAB CONTROL BOX	
1	LM-241101	1	EM PLT, CAB CONTROL BOX MNT	
2	LM-252611	1	EM LID, CAB CONTROL BOX	
3	LM-241122	1	EM, CAB CONTROL BOX	
4	EC-138791	1	STRAIN RELIEF, NYLON, BLK, PG 13.5	
5	EC-138801	1	STRAIN RELIEF NUT, NYLON, BLK, PG 13.5	
6	LA-259671	1	SWITCH ASM, LEFT-RIGHT	
7	LM-252621	1	EM MOUNT, MAX LEVEL LAMP	
8	EC-140761	1	LENSE, YELLOW	
9	EC-140871	1	LED	
10	LA-259661	1	SWITCH ASM, AUTO-OFF-MAN	
11	EC-140751	2	GANG MOUNT	
12	EC-140771	1	BEZEL, CENTER	
13	EC-136211	1	3AG FUSE HOLDER	
14	EC-136221	1	AGC-6A FUSE	
CAB CONSOLE CONTROL BOX FASTENERS				
REF.	PART NO.	QTY.	PART NAME	WHERE USED
A	MC-139941	2	#14 X 3/4 HEX CAP METAL SCREW	CAB CONTROL BOX
B	F-PHM-#6C12	2	PHMS 6-32 X 3/4	CAB CONTROL BOX
B	F-HNF-#6C	2	FLHN 6-32	CAB CONTROL BOX
MAIN ELECTRICAL BOX COMPONENTS				
REF.	PART NO.	QTY.	PART NAME	DESCRIPTION
ASM	LA-257371	1	EM ASM, CONTROLLER	
15	LM-236473	1	EM PLATE, CONTROL BOX MOUNT	
16	LM-255341	1	EM BOX, CONTROLLER MOUNT	
17	EC-141831	1	CONTROLLER	
18	LA-255821	1	EM ASM, CLINOMETER	
19	LM-255331	1	EM SHT, CLINOMETER MOUNT	
20	EC-100557	2	BODY, LIMIT SWITCH	
21	EC-100692	2	HEAD, LIMIT SWITCH STRAIGHT PLUNGER	
22	EC-138781	6	STRAIN RELIEF, NYLON, BLK, 1/2 NPT	
23	EC-142121	4	STRAIN RELIEF NUT, 1/2" NYLON, BLK	
MAIN ELECTRICAL BOX FASTENERS				
REF.	PART NO.	QTY.	PART NAME	WHERE USED
C	F-PHM-#10C28	4	PHMS 10-24 X 1-3/4	LIMIT SWITCH MNT
C	F-HNF-#10C	4	HN 10-24, FLNG SERR	LIMIT SWITCH MNT
D	F-HC5-04C12	3	HC5 1/4-20 X 3/4	PVC BOX TO BRACKET
D	F-LW-04	3	LW 1/4	PVC BOX TO BRACKET
E	F-PHM-#6C06	2	PHMS #6-32 X 3/8	CLINOMETER MOUNT
F	F-PHM-04C24	2	PHMS 1/4-20 X 1-1/2	CONTROLLER TO PVC BOX
F	F-HNF-04C	2	FLHN 1/4-20 SERR.	CONTROLLER TO PVC BOX
G	F-PHM-04C36	2	PHMS 1/4-20 X 2-1/4	GROUNDING PLATE MOUNTING
G	F-HNF-04C	2	FLHN 1/4-20 SERR.	GROUNDING PLATE MOUNTING
H	F-PHM-#10C16	2	PHMS 10-24 X 3/4	GROUND
H	F-HNF-#10C	2	HN5 10-24, FLNG SERR	GROUND
H	F-HN-#10C	2	HN5 10-24	GROUND
I	F-HC-10M025F	4	HC- 8.8 M10 X 1.50 X 25	
I	F-HNF-10MF	4	FLHN 8.8 M10 X 150	

Model 2960 Hillco Leveling System
For Serial Number 2960-1201 thru 2960-1299

ELECTRICAL CONNECTORS

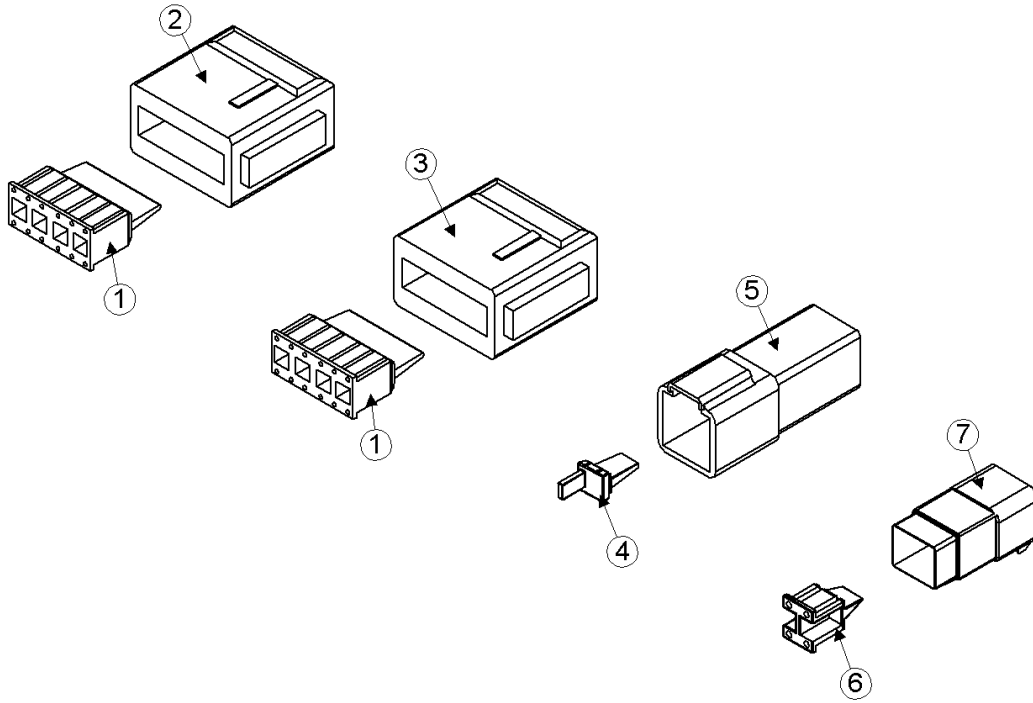

Model 2960 Hillco Leveling System
For Serial Number 2960-1201 thru 2960-1299

ELECTRICAL CONNECTORS				
REF.	PART NO.	QTY.	PART NAME	NOTES
1	EC-141741	2	DTM SERIES 12-SOCKET WEDGE	
2	EC-141751	1	DTM SERIES 12-SOCKET PLUG W/ A-KEY	
3	EC-141761	1	DTM SERIES 12-SOCKET PLUG W/ B-KEY	
4	EC-141821	1	DTM SERIES 4-PIN WEDGE	
5	EC-141811	1	DTM SERIES 4-PIN RECEPTACLE	
6	EC-141801	1	DTM SERIES 4-SOCKET WEDGE	
7	EC-141791	1	DTM SERIES 4-SOCKET PLUG	
NS	EC-141771	10	DTM SERIES SOCKET CONTACT, STAMPED	
NS	EC-141781	4	DTM SERIES PIN CONTACT, STAMPED	
NS	ET-ST-20#10	6	TERMINAL, RING, #10, 20 GA., NON-INSULATED	
NS	ET-ST-2004	1	TERMINAL, RING, NON-INS, 1/4, 20 GA	
NS	EC-136651	1	WP CONN. ASM. 1M	
NS	EC-136661	4	WP PIN TERM	
NS	EC-136681	1	WP CONN. ASM.4F	
NS	EC-136621	1	WP FM SLEEVE TERM	
NS	EC-136631	2	WP CABLE SEAL	
NS	EC-133281	2	DIODE, 6 AMP, 50 PIV, SILICON	
NS	EC-136711	1	AMP SOCKET	
NS	EC-136741	1	AMP CPC CABLE CLAMP	
NS	EC-136731	1	AMP STD. SEX PLUG	
NS	ET-ST-2005	2	5/16 STUD TERMINAL	
NS	EC-139631	1	CONNECTOR, PARALLEL 12-10 GA	
NS	EC-139641	2	CONNECTOR, PARALLEL 16-14 GA	
NS	EC-140891	8	SPADE, FEMALE, INSULATED, 16-22 GA	

Model 2960 Hillco Leveling System
For Serial Number 2960-1201 thru 2960-1299

ELECTRICAL CABLES



#1 LA-255631
EM CABLE ASM, LIMIT
SWITCH



#2 LA-257231
EM CABLE ASM, BOX TO VALVE



#3 LA-255821
EM ASM, CLINOMETER



#4 LA-249062
EM CABLE ASM, LEVELING VALVE



#5 LTA-242271
LTM CABLE MAIN WITH DIODES



#6 LA-257331
EM CABLE ASM, CAB TO BOX



#7 LTA-242291
LTM CABLE FOR OLDER JD COMBINES



#8 LTA-242281
LTM CABLE FOR DUMP VALVE



#9 LTA-243931
AUTO LATERAL TILT CABLE
ASSEMBLY

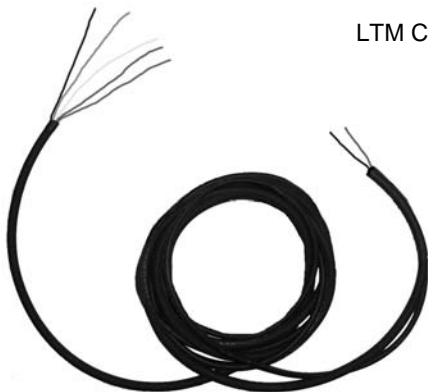

#10 LA-257361
EM ALL CABLE ASM, CAB TO BOX,
EARLY



#11 LA-257311
EM ALL CABLE ASM, CAB TO BOX,
LATE

Model 2960 Hillco Leveling System
For Serial Number 2960-1201 thru 2960-1299

ELECTRICAL CABLES				
REF.	PART NO.	QTY.	PART NAME	NOTES
FOR ALL COMBINES				
1	LA-255631	2	EM CABLE ASM, LIMIT SWITCH	
2	LA-257231	1	EM CABLE ASM, BOX TO VALVE	
3	LA-255821	1	EM ASM, CLINOMETER	
4	LA-249062	1	EM CABLE ASM, LEVELING VALVE	
5	LTA-242271	1	LTM CABLE MAIN W/ DIODES	
FOR COMBINES WITH SERIAL NUMBERS: 9600 (-660300)				
6	LA-257331	1	EM CABLE ASM, CAB TO BOX	
7	LTA-242291	1	LTM CABLE FOR OLDER JD COMBINES	FOR MANUAL HEADER TILT
8	LTA-242281	1	LTM CABLE FOR DUMP VALVE	
9	LTA-243931	1	AUTO LATERAL TILT CABLE ASSEMBLY	FOR AUTOMATIC HEADER TILT
..	LTA-248901	1	CABLE A (FEEDER HOUSE CABLE)	INCLUDED IN LA-243931
..	LTA-248911	1	CABLE B (VALVE CABLE)	INCLUDED IN LA-243931
..	LTA-248921	1	CABLE C (CAB CABLE)	INCLUDED IN LA-243931
FOR COMBINES WITH SERIAL NUMBERS: 9600 & 9610 (660301-)				
6	LA-257331	1	EM CABLE ASM, CAB TO BOX	
8	LTA- 242281	1	LTM CABLE FOR DUMP VALVE	FOR HEADER TILT
FOR EARLY 50 SERIES COMBINES WITH SERIAL NUMBERS: 9650 (-695300)				
10	LA-257361	1	EM ALL CABLE ASM, CAB TO BOX, EARLY	
..	LA-257321	1	EM CABLE ASM, CAB TO BOX	INCLUDED IN LA-257361
..	LA-252462	1	EM CABLE ASM, MAX LEVEL LIGHT	INCLUDED IN LA-257361
FOR LATE 50 SERIES COMBINES WITH SERIAL NUMBERS: 9650 (695301-)				
11	LA-257311	1	EM ALL CABLE ASM, CAB TO BOX, LATE	
..	LA-255621	1	EM CABLE ASM, RESISTOR	INCLUDED IN LA-257311
..	LA-257301	1	EM CABLE ASM, CAB TO BOX	INCLUDED IN LA-257311
..	LA-252462	1	EM CABLE ASM, MAX LEVEL LIGHT	INCLUDED IN LA-257311

8 HYDRAULICS

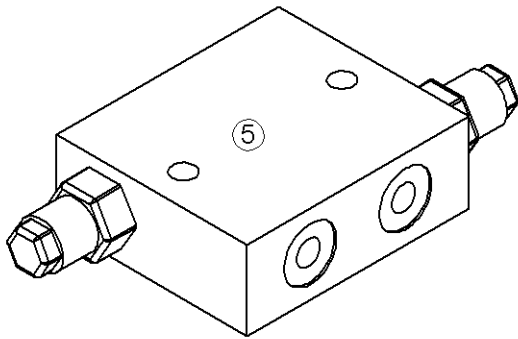
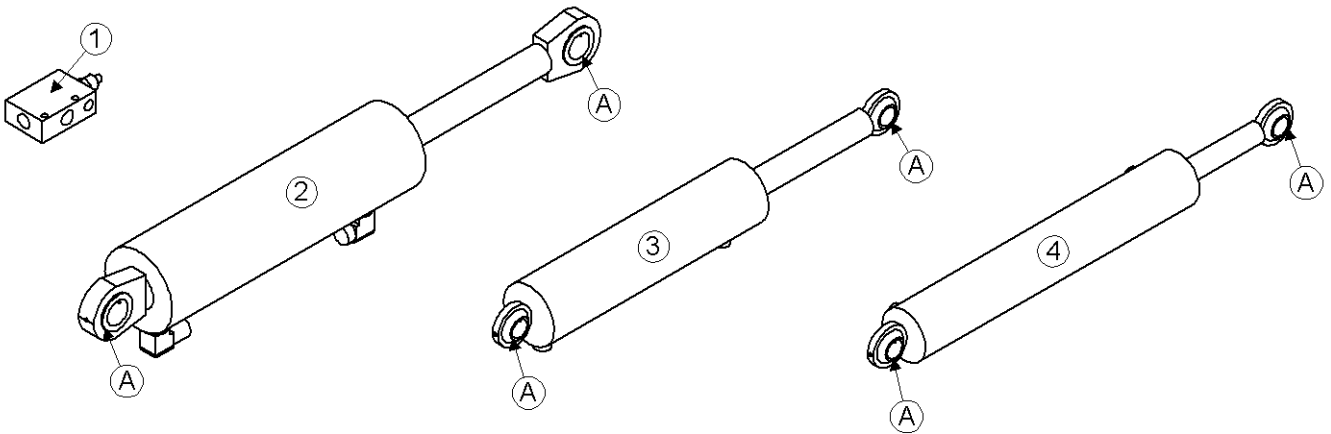

MANIFOLD, RELIEF VALVE

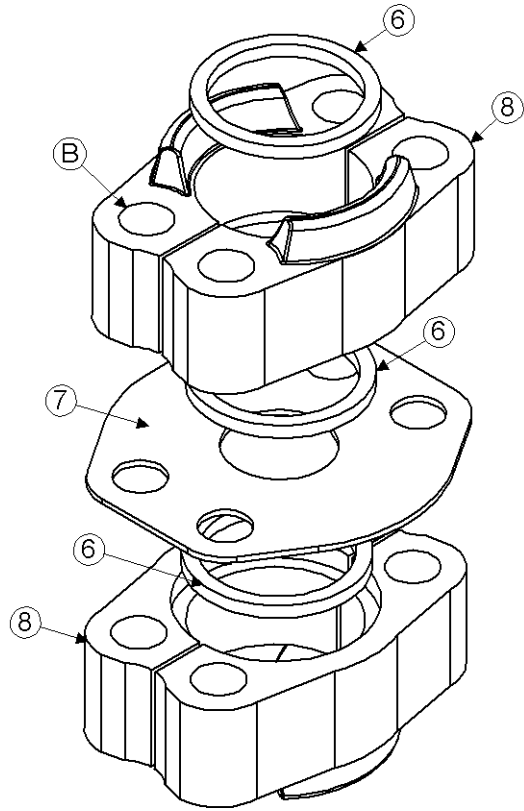

CODE 62 SPLIT FLANGE
CONNECTOR KIT
ASSEMBLY WITH O-RINGS

Model 2960 Hillco Leveling System
For Serial Number 2960-1201 thru 2960-1299

HYDRAULIC COMPONENTS & FASTENERS				
REF.	PART NO.	QTY.	PART NAME	DESCRIPTION
1	HC-139151	2	VALVE, 3-PORT COUNTERBALANCE	
..	HC-139181	2	BODY, COUNTERBALANCE VALVE	
..	HC-139161	2	CARTRIDGE, COUNTERBALANCE VALVE	
NS	HC-140361	2	SEAL KIT, COUNTERBALANCE VALVE	
2	HC-103228	2	CYLINDER, MAIN LEVELING	
NS	HC-134251	2	SEAL KIT, MAIN LEVELING CYLINDER	
3	HC-101842	1	CYLINDER, MASTER	
NS	HC-134201	1	SEAL KIT, MASTER CYLINDER	
4	HC-100706	1	CYLINDER, SLAVE	
NS	HC-134191	1	SEAL KIT, SLAVE CYLINDER	
5	HC-138691	1	MANIFOLD, RELIEF VALVE	
NS	HC-141351	2	CARTRIDGE, RELIEF VALVE	
NS	HC-141361	1	SEAL KIT, RELIEF VALVE	
A	F-SSS-04F04	6	SET SCREW, SOCKET 1/4-28 X 1/4, GRADE 8	MASTER AND MAIN CYLINDERS
CODE 62 SPLIT FLANGE CONNECTOR KIT ASSEMBLY				
ASM	HC-101843	2	CODE 62 SPLIT FLANGE CONNECTOR KIT WITH O-RINGS	FWD AND REAR PROPULSION HOSE
ONE HC-101843 KIT INCLUDES				
6	HC-134911	3	O-RINGS, CODE 62 CONNECTOR	
7	HC-137891	1	PLATE, CODE 62	
8	HC-137901	2	CODE 62, #16 SPLIT FLANGE KIT	
B	F-HC8-07C44	4	HC8 7/16 X 2-3/4	
B	F-HN8-07C	4	HN8 7/16-14	

Model 2960 Hillco Leveling System
For Serial Number 2960-1201 thru 2960-1299
HYDRAULIC MANIFOLD

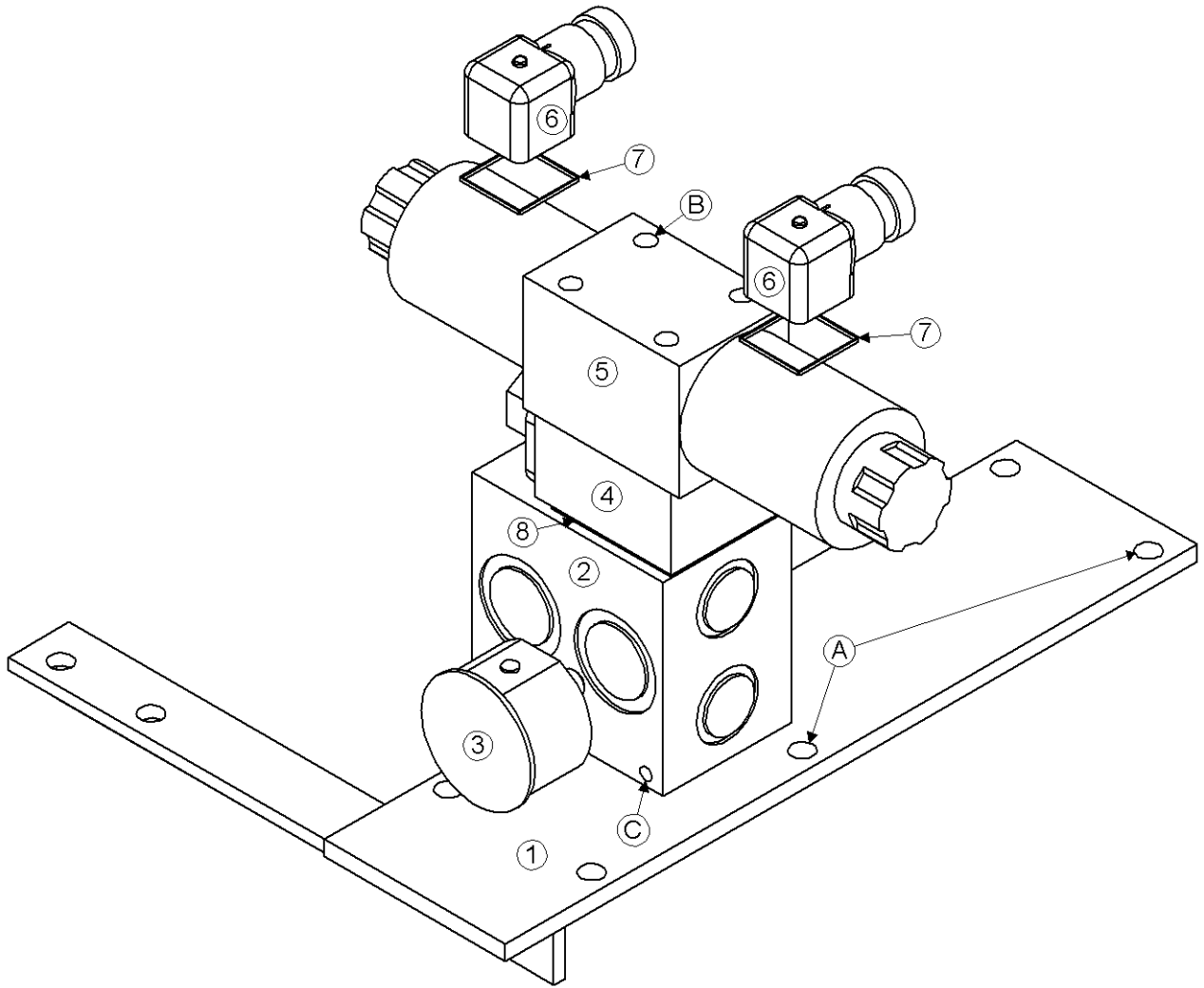

Model 2960 Hillco Leveling System
For Serial Number 2960-1201 thru 2960-1299

MANIFOLD COMPONENTS				
REF.	PART NO.	QTY.	PART NAME	NOTES
ASM	LA-257291	1	MANIFOLD ASM, SINGLE STATION	
1	LA-229292	1	HM MOUNT ASM, MANIFOLD	
2	HC-138861	1	MANIFOLD, SINGLE STATION	
3	HC-101019	1	3000 PSI PRESSURE GUAGE W/ 1/4" MPT	
4	HC-101264	1	LOAD SENSE SHUTTLE ASM	
..	HC-101021	1	CARTRIDGE, LOAD SENSE VALVE	
..	HC-101022	1	BODY, LOAD SENSE VALVE	
NS	HC-102082	1	SEAL KIT, LOAD SENSE SHUTTLE ASM	
5	HC-140411	1	VALVE, DIRECT CONTROL, PROPORTIONAL	
NS	HC-142731	1	SEAL KIT, DIRECTIONAL CONTROL VALVE	
6	HC-140291	2	PLUG, DIN LIGHTED	
7	HC-142971	3	GASKET, DIN CONNECTOR	COILS ON DIR CONTROL VALVE
8	HC-142761	1	SUBPLATE	
NS	HC-143971	8	O-RINGS DO3 SUBPLATE	JD P/N A3917R
MANIFOLD FASTENERS				
REF.	PART NO.	QTY.	PART NAME	WHERE USED
A	F-HC-08M020F	8	HC-8.8 M8 X 1.25 X 20	MANIFOLD BRACKET
A	F-HNF-08MF	8	FLHN-8.8 M8 X 1.25	MANIFOLD BRACKET
B	F-SHC-#10C52	4	SHCS 10-24 X 3-1/4	LEVELING STATION OF MANIFOLD
B	F-LW-#10	4	LW #10	LEVELING STATION OF MANIFOLD
C	F-HCF-05C08	4	HC5 5/16 X 1/2 FLNG	MANIFOLD TO BRACKET

Model 2960 Hillco Leveling System
For Serial Number 2960-1201 thru 2960-1299

HYDRAULIC PUMP

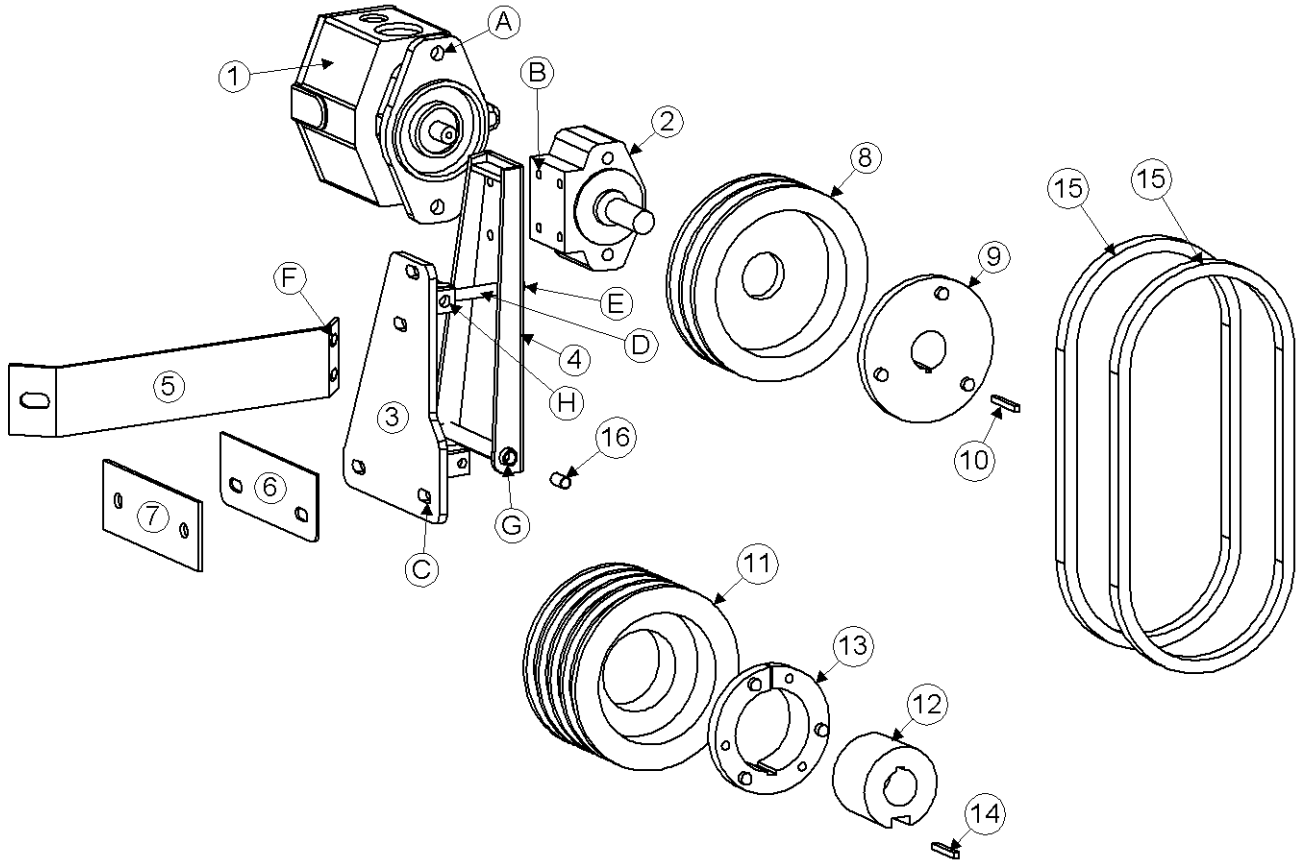

Model 2960 Hillco Leveling System
For Serial Number 2960-1201 thru 2960-1299

PUMP COMPONENTS				
REF.	PART NO.	QTY.	PART NAME	DESCRIPTION
1	HC-133151	1	PUMP, HYDRAULIC PFC-116	
..	HC-135231	1	SEAL KIT, PUMP	
..	HC-135241	1	SEAK, PUMP MAIN SHAFT	
..	HC-135251	2	SEAL, PINTLE SHAFT	
..	HC-103099	1	COMPENSATOR #2	
..	HC-137061	1	KEY, HYDRAULIC PUMP SHAFT	
2	HC-141531	1	ADAPTER, OVER-HUNG LOAD (300 SERIES)	
NS	LA-259551	1	REBUILD KIT, 300 OHLA	
3	LA-235371	1	HM PUMP DR, ASM MNT	
4	LA-235381	1	HM PUMP DR, PUMP MNT ASM	
5	LM-235821	1	HM PUMP DR, GUSSET	
6	LP-235311	1	HM PUMP DR, SPACER PLT	
7	LM-235831	1	HM PUMP DR,STIFFENER PLT	
8	MC-134331	1	SHIEVE, 2 GROOVE, 8.5"	
9	MC-134341	1	BUSHING, SF 1	
10	LS-235291	1	HM KEY, OHLA	
11	MC-134321	1	SHIEVE, 4 GROOVE, 8"	
12	LM-235281	1	HM PUMP DR, HUB	
13	MC-134351	1	BUSHING, 3-1/2 TAPER LOCK	
14	LM-236611	1	KEY 3-1/2 QD HUB	
15	MC-134361	2	BELT, V C46	
16	MC-136251	2	BUSHING, PLANE OILLITE BRONZE	PUMP DRIVE PIVOT BUSHING
NS	LA-262131	1	KIT, LUBRICATION 2960 OHLA	
PUMP FASTENERS				
REF.	PART NO.	QTY.	PART NAME	WHERE USED
A	F-HC-10M110E	2	HC-10.9 M10 X 1.50 X 110	PUMP TO ADAPTER MOUNT
A	F-HNF-10ME	2	FLHN-10.9 M10 X 1.50	PUMP TO ADAPTER MOUNT
B	F-HC8-06C20	4	HC8 3/8-16 X 1-1/4	OHLA MOUNT
B	F-LW-06A	4	LW 3/8 HD	OHLA MOUNT
C	F-HC-12M040E	4	HC-10.9 M12 X 1.75 X 40	PUMP MNT TO GRAIN TANK
C	F-HNS-12ME	4	HN-10.9 M12 X 1.75 STV	PUMP MNT TO GRAIN TANK
C	F-FWH-08	8	FW 1/2 HD	PUMP MNT TO GRAIN TANK
D	F-EYB-12M100F	1	EYE BOLT-8.8 M12 X 1.75 X 100	BELT TIGHTENER
E	F-HNN-12MF	1	HN-8.8 M12 X 1.75 NYLOCK	BELT TIGHTENER
E	F-FWH-08	1	FW 1/2 HD	BELT TIGHTENER
F	F-HCF-10M040E	1	FLHC-10.9 M10 X 1.50 X 40	GRAINTANK GUSSET
F	F-HNF-10ME	1	FLHN-10.9 M10 X 1.50	GRAINTANK GUSSET
G	F-HC-10M200E	1	HC-10.9 M10 X 1.5 X 200	PUMP MNT SWING BOLT
G	F-HNN-10MF	1	HN-8.8 M10 X 1.5 NYLOCK	PUMP MNT SWING BOLT
H	F-HC-12M060F	1	HC-8.8 M12 X 1.75 X 60	BELT TIGHTENER PIVOT BOLT
H	F-HNN-12MF	1	HN-8.8 M12 X 1.75 NYLOCK	BELT TIGHTENER PIVOT BOLT

Model 2960 Hillco Leveling System
For Serial Number 2960-1201 thru 2960-1299

HEADER TILT VALVE

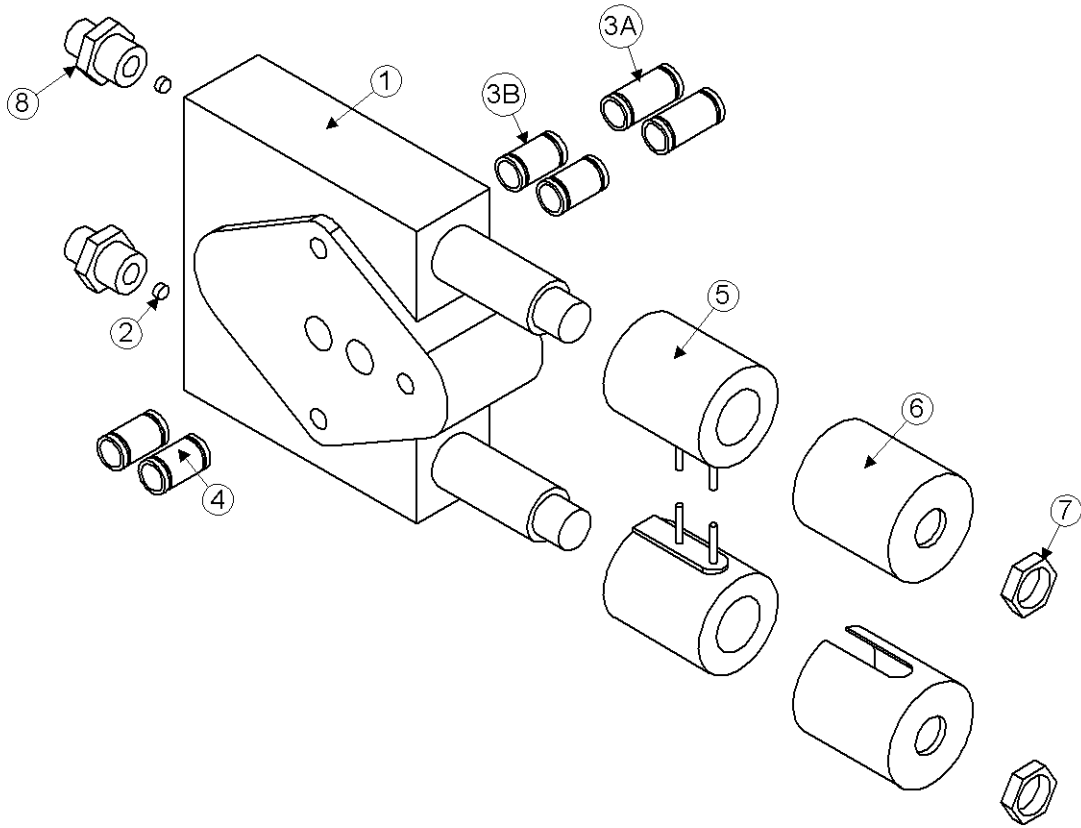

Model 2960 Hillco Leveling System
For Serial Number 2960-1201 thru 2960-1299

HEADER TILT VALVE COMPONENTS				
REF.	PART NO.	QTY.	PART NAME	NOTES
FOR COMBINES WITHOUT CONTOUR MASTER:				
ASM	LA-256321	1	HM VALVE ASM, LATERAL TILT 2960H	
1	HC-136511	1	LATERAL TILT VALVE	
2	LM-254541	2	ORIFICE (DRILLED TO .040)	
3A	HC-136541	2	LONG THROUGH TUBES	
3B	HC-136551	2	SHORT THROUGH TUBES	9650
4	HC-136551	2	SHORT THROUGH TUBES	
5	HC-136561	2	COILS	
6	HC-136571	2	COIL COVERS	
7	HC-136581	2	COIL COVER NUTS	
8	HA-S-8MO4MF	2	#8 MORB X #4 MORS STR	
NS	HC-136591	1	COVER	
MISCELLANEOUS HEADER TILT VALVE COMPONENTS				
NS	LA-130343	1	1/4 100R2 22" #4 FORS BOTH ENDS	CM VALVE REAR PORT TO RELIEF VALVE PORT #1
NS	LA-130343	1	1/4 100R2 22" #4 FORS BOTH ENDS	CM VALVE FRONT PORT TO RELIEF VAVLE PORT #2
NS	LA-142351	1	1/4 100R2 160" #4 FORS BOTH ENDS	RELIEF VALVE PORT #1 TO MASTER ROD
NS	LA-142351	1	1/4 100R2 160" #4 FORS BOTH ENDS	RELIEF VALVE PORT #2 TO MASTER BASE
NS	LA-142361	1	1/4 100R2 321" #4 FORS 90° X #6 FORS STR	RELIEF VALVE PORT #1 TO SLAVE ROD
NS	LA-142361	1	1/4 100R2 321" #4 FORS 90° X #6 FORS STR	RELIEF VALVE PORT #2 TO SLAVE BASE
NS	HA-S-4MF4MO	2	#4MORB X #4MORS STR	LATERAL TILT RELIEF VALVE
NS	HA-T-4MF4MO	2	#4 MORB X #4 MORS STR THREAD RUN TEE	LATERAL TILT RELIEF VALVE

Model 2960 Hillco Leveling System
For Serial Number 2960-1201 thru 2960-1299

HYDRAULIC HOSES

REF.	PART NO.	QTY.	PART NAME	DESCRIPTION
GREASE				
FOR ALL COMBINES				
NS	LA-133672	1	3/16 100R7 70" 1/8 MP X 1/8 MP	LEFT LEV CYL BASE TO GREASE BULKHEAD #1
NS	LA-133672	1	3/16 100R7 70" 1/8 MP X 1/8 MP	MASTER ROD TO GREASE BULKHEAD #2
NS	LA-133692	1	3/16 100R7 29.25" 1/8 MP X 1/8 MP	MASTER BASE TO GREASE BULKHEAD #3
NS	LA-133692	1	3/16 100R7 29.25" 1/8 MP X 1/8 MP	RIGHT LEV CYL BASE TO GREASE BULKHEAD #4
NS	LA-135611	1	3/16 100R7 57" 1/8 MP X 1/8 MP	MAIN PIVOT PIN TO BULKHEAD #5
NS	HC-138011	5	1/4-28 STRAIGHT ZERK	ALL GREASE LINES
NS	HA-S-2MN2FP	5	1/8 NPSM X 1/8 FPT BULKHEAD CONNECTOR	BULKHEAD CONNECTOR
NS	HA-NJ-2FN	5	1/8 NPSM BULKHEAD LOCKNUT	BULKHEAD CONNECTOR
NS	HA-L-2FP2MP	1	1/8 MPT 90 STREET EL	MAIN PIVOT PIN
NS	HC-135761	2	1/4-28 MALE X 1/8 FPT 45°	LEFT MAIN AND MASTER CYLINDER BASE
NS	HC-135881	2	1/4-28 MALE X 1/8 FPT STR	RIGHT MAIN CYLINDER BASE AND MASTER ROD
BRAKE				
FOR ALL COMBINES				
NS	LA-130371	1	#4 TITE FLEX 31" #4 FORS X #4 MORS	BRAKE LINE LEFT
NS	LA-130371	1	#4 TITE FLEX 31" #4 FORS X #4 MORS	BRAKE LINE RIGHT
NS	HA-133131	2	TEFLON O-RING	LEFT AND RIGHT BRAKE HOSE
FOR COMBINES WITH SERIAL NUMBERS: 9600 (-640301)				
NS	LA-136191	1	1/4 100R2 135" #6 FORS X #6 FORS 90°	PARK BRAKE LINE
PUMP				
FOR ALL COMBINES				
NS	LA-133932	1	1/2 100R2 138" #10 FORS BOTH ENDS	PRESSURE PUMP TO MANIFOLD "P" PORT
NS	LA-133952	1	1/4 100R2 126" #4 FORS 90 X #6 FORS STR	LOAD SENSE PUMP TO MANIFOLD
NS	LA-133912	1	1 100R1 96" #16 FORS X #16 FORS 90°	SUCTION RESERVOIR TO PUMP
NS	LA-133922	1	3/8 100R2 96" #6 FORS X #6 FORS 90°	RESERVOIR TO PUMP CASE DRAIN
HYDROSTAT				
FOR ALL COMBINES				
NS	LA-130762	1	3/4" 100R1 135" #12 FORS X #12 FORS 45°	HYDROSTAT RETURN HOSE
FOR COMBINES WITH SERIAL NUMBERS: 9600 (-655300) STEEL LINES				
NS	LA-135011	1	1 100R15 119" CODE 62 SPLT FLNG STR X CODE 62 SPLT FLNG 180°	HYDROSTAT HIGH PRESSURE HOSE
NS	LA-136181	1	1 100R15 114" CODE 62 SPLT FLNG STR X CODE 62 SPLT FLNG 180°	HYDROSTAT HIGH PRESSURE HOSE
FOR COMBINES WITH SERIAL NUMBERS: 9600 (655301-); 9610 COMBINES NO STEEL LINES				
NS	LA-130771	1	1 100R15 49" CODE 62 SLT FLNG STR. X CODE 62 SLT FLNG 90° (SHORT DROP)	HYDROSTAT HIGH PRESSURE HOSE
NS	LA-137881	1	1 100R15 78" CODE 62 SLT FLNG STR. X CODE 62 SLT FLNG 90° (SHORT DROP)	HYDROSTAT HIGH PRESSURE HOSE

Model 2960 Hillco Leveling System
For Serial Number 2960-1201 thru 2960-1299
HYDRAULIC HOSES (CONTINUED)

LEVELING MANIFOLD				
FOR ALL COMBINES				
NS	LA-130312	1	3/4 100R1 50" #10 FORS X #12 FORS	MANIFOLD "T" PORT TO RETURN LINE
NS	LA-142331	1	1/2 100R2 99" #8 FORS BOTH ENDS	LEVELING VALVE "A" PORT TO ROD END OF LEFT MAIN LEV CYLINDER
NS	LA-142341	1	1/2 100R2 108" #8 FORS BOTH ENDS	LEVELING VALVE "B" PORT TO BASE END OF LEFT MAIN LEV CYLINDER
FEEDER HOUSE				
FOR ALL COMBINES				
NS	LA-135051	1	1/2 100R2 30" #8 MORS X #8 FORS	FEEDER HOUSE HOSE EXTENSIONS
NS	LA-135061	1	3/8 100R2 30" #6 MORS X #6 FORS	FEEDER HOUSE HOSE EXTENSIONS
NS	LA-135071	1	1/2 100R2 136-3/4" #8 MORB X #8 FORS	FEEDER HOUSE HOSE EXTENSIONS
NS	LA-135081	1	1/2 100R2 139-3/4" #8 MORB X #10 FORS	FEEDER HOUSE HOSE EXTENSIONS
NS	LA-135091	1	3/8 100R2 154" #6 FORS X #4 FORS	FEEDER HOUSE HOSE EXTENSIONS
*NO FEEDERHOUSE HOSES ARE REQUIRED FOR 9650W COMBINES WITH SERIAL NUMBERS (695301-)				
HEADER LIFT CYLINDER HOSES				
FOR ALL COMBINES				
NS	LA-133631	1	1/2 100R2 82" #8 FORS BOTH ENDS	RIGHT HDR LFT CYLINDER TO BULKHEAD #1 RIGHT
NS	LA-133631	1	1/2 100R2 82" #8 FORS BOTH ENDS	LEFT HDR LFT CYLINDER TO BULKHEAD #1 LEFT
NS	LA-136071	1	1/2 100 R2 105" #8 FORS BOTH ENDS	TEE AT ACCUMULATOR VALVE TO BULKHEAD #1
MAIN CYLINDER				
FOR ALL COMBINES				
NS	LA-130383	1	1/2" 100R2 HOSE 57" #8 FORS X #8 FORS 90°	LEFT MAIN ROD TO RIGHT POCV #2
NS	LA-130383	1	1/2" 100R2 HOSE 57" #8 FORS X #8 FORS 90°	RIGHT MAIN ROD TO LEFT POCV #2
NS	LA-130483	1	3/8" 100R2 HOSE 19-1/2" #6 FORS X #8 FORS 90°	RIGHT POCV #3 TO RIGHT MAIN ROD
NS	LA-130483	1	3/8" 100R2 HOSE 19-1/2" #6 FORS X #8 FORS 90°	LEFT POCV #3 TO LEFT MAIN ROD
NS	HC-142271	2	ABRASION SLEEVE, NYLON -- 1.81" ID X 8"	1/2" HOSES BETWEEN LEVELING CYLINDERS
MISCELLANEOUS				
FOR COMBINES WITH REAR WHEEL ASSIST AND A JOHN DEERE CHAFF SPREADER				
NS	LA-143651	1	3/4" 100R1 HOSE 44" #12 FORS X #12 FORS 90°	REPLACES STEEL LINE AT BOTTOM OF UNION

Model 2960 Hillco Leveling System
For Serial Number 2960-1201 thru 2960-1299

HYDRAULIC ADAPTERS

REF.	PART NO.	QTY.	PART NAME	DESCRIPTION
PUMP				
FOR ALL COMBINES				
NS	HA-S-10MF10MO	1	#10 MORB X #10 MORS	PUMP PRESSURE
NS	HA-L-6MF4MO	1	#4 MORB X #6 MORS 90°	PUMP LOAD SENSE
NS	HA-L-6MF6MO	2	#6 MORS X #6 MORB 90°	PUMP CASE DRAIN
NS	HA-S-12MO16MF	1	#12 MORB X #16 MORS	PUMP SUCTION
HEADER LIFT CYLINDERS				
FOR ALL COMBINES				
NS	HA-L-8FF8MF	2	#8 FORS X #8 MORS 90	HEADER LIFT CYLINDERS
MAIN CYLINDERS				
FOR ALL COMBINES				
NS	HA-L-8MO8MO	2	8 MORB X 8 MORB 90°	LEFT AND RIGHT POCV #1
NS	HA-T-8MF8MO	1	#8 MORB X #8 MORS STR THREAD RUN TEE	LEFT POCV #2
NS	HA-Q-8MF8MO	2	#8 MORB X #8 MORS STR THREAD BRANCH TEE	LEFT AND RIGHT MAIN ROD
NS	HA-M-8F	1	#8 ORS SWIVEL NUT RUN TEE	LEFT MAIN ROD
NS	HA-L-6MF6MO	2	#6 MORS X #6 MORB 90°	LEFT AND RIGHT POCV #3
NS	HA-L-8MF8MO	1	#8 MORS X #8 MORB 90°	RIGHT POCV #2
MASTER CYLINDER				
FOR ALL COMBINES				
NS	HA-L-4MF6MO	1	#4 MORS X #6 MORB 90°	MASTER ROD
NS	HA-L-4MF6MO	1	#4 MORS X #6 MORB 90°	MASTER BASE
BULKHEAD MOUNT				
FOR ALL COMBINES				
NS	HA-J-8MF8MF	1	#8MORS X #8MORS X #8 MORS BULKHEAD RUN TEE	BULKHEAD #1 POINTED UP
NS	HA-NB-8FF	1	#8 ORS STR THREAD BULKHEAD LOCKNUT	BULKHEAD #1
RESERVOIR				
FOR ALL COMBINES				
NS	HA-T-6MF6MO	1	#6 MORB X #6 MORS STR THREAD RUN TEE	CASE DRAIN AT RESERVOIR
NS	HA-C-6F	1	#6 FORS CAP	CASE DRAIN AT RESERVOIR
NS	HA-M-16F	1	#16 ORS SWIVEL NUT RUN TEE	SUCTION BY JD FILTER
MANIFOLD				
NS	HA-A-10MO	1	#10 MORB ALLEN HEAD PLUG	"T" PORT
NS	HA-S-4FP10MO	1	#10 MORB X #4 FNPT STR	"P" PORT FOR PRESSURE GAUGE
NS	HA-S-10MF10MO	2	10 MORB X 10 MORS STR	"P" & "T" PORTS
NS	HA-L-10FF10MF	2	10 FORS X 10 MORS 90°	"P" & "T" PORTS
NS	HA-L-8MF8MO	2	#8 MORB X #8 MORS 90°	"A" & "B" PORTS
NS	HA-L-4MF4MO	1	#4 MORS X #4 MORB 90°	LOAD SENSE SHUTTLE
NS	HA-S-10MF10MO	1	10 MORB X 10 MORS STR	PRESSURE IN
NS	HA-L-10FF10MF	1	10 FORS X 10 MORS 90°	PRESSURE IN
NS	HA-L-4MF4MO	1	#4 MORS X #4 MORB 90°	LOAD SENSE SHUTTLE
NS	HA-A-10MO	1	#10 MORB ALLEN HEAD PLUG	"T" PORT
NS	HA-S-10MF10MO	1	10 MORB X 10 MORS STR	TANK OUT
NS	HA-L-10FF10MF	1	10 FORS X 10 MORS 90°	TANK OUT
NS	HA-S-4FP10MO	1	#10 MORB X #4 FNPT STR	PRESSURE GAUGE
NS	HA-L-8MF8MO	2	8 MORB X 8 MORS 90°	LEV A&B
MISCELLANEOUS				
FOR COMBINES WITH REAR WHEEL ASSIST AND A JOHN DEERE CHAFF SPREADER				
NS	HA-M-12MF12MF	1	#12 ORS SWIVEL NUT RUN TEE	AT TEE UNION BY RETURN FILTER
NS	HA-S-4MF8MO	2	#8 MORB X #4 MORS STR	
NS	HA-E-4MF	2	#4 MORS PLUG	
NS	HA-E-6MF	2	#6 MORS PLUG	

Model 2960 Hillco Leveling System
For Serial Number 2960-1201 thru 2960-1299

9 MISCELLANEOUS

DOCUMENTS AND LABELS				
REF.	PART NO.	QTY.	PART NAME	DESCRIPTION
NS	LL-142091	2	DECAL, JD HILLSIDE LEVELING SYSTEM	
NS	LL-133731	5	LABEL, GREASE 10 HR	
NS	LL-138441	1	DECAL, CAB CONTROL BOX	
NS	LL20-100786	1	LABEL, SAFETY	WARNING, ELECTRONIC CRUSHING HAZARD
NS	LL20-100785	1	LABEL, SAFETY	CAUTION, MOVING STEP
NS	LL20-100782	1	LABEL, SAFETY	CAUTION, LEVELING SYSTEM CAB
NS	LL20-100784	2	LABEL, SAFETY	DANGER, PINCH POINT
NS	LL20-100787	2	LABEL, SAFETY	CAUTION, LEVELING SYSTEM HAZARD
NS	LL20-100788	3	LABEL, SAFETY	DANGER, HYDRAULIC HAZARD
NS	LL20-100783	6	LABEL, SAFETY	DANGER, CRUSHING HAZARD
NS	LL-143621	2	LABEL, SAFETY	DANGER, AVOID CRUSHING INJURY
NS	LL20-100790	1	SERIAL NUMBER PLATE	REAR OF UNDERCARRIAGE
NS	D-020830DJC01	1	JD 2950/2960 INSTALLATION MANUAL	
NS	D-020903CLA01	1	JD 2950/2960 OPERATOR'S MANUAL	
NS	D-070522ADL01	1	MANUAL, PARTS	
HOSE CLAMPS AND FASTENERS				
REF.	PART NO.	QTY.	PART NAME	WHERE USED
NS	F-HC-08M120F	1	HC-8.8 M8 X 1.25 X 120	TRIM RELIEF VALVE TO BEHRINGER CLAMP
NS	F-HNN-08MF	1	HN-8.8 M08 X 1.25 NYLOCK	TRIM RELIEF VALVE TO BEHRINGER CLAMP
NS	MC-137521	2	BEHRINGER TWIN CLAMP (1.500 DIAMETER)	HYDROSTAT HOSES
NS	MC-137531	2	BEHRINGER TWIN COVER PLATE (FOR 1.500)	HYDROSTAT HOSES
NS	HC-140461	1	BEHRINGER TWIN CLAMP .875" DIAMETER	ON OC HOSES BETWEEN CYLINDERS
NS	HC-142281	1	BEHRINGER STACK BOLT (FOR .875)	ON OC HOSES BETWEEN CYLINDERS
NS	HC-139501	1	BEHRINGER TWIN COVER PLATE (FOR .620)	ON OC HOSES BETWEEN CYLINDERS
NS	HC-139511	1	BEHRINGER TWIN BOLT (FOR .620)	ON OC HOSES BETWEEN CYLINDERS
NS	HC-139481	1	BEHRINGER TWIN CLAMP .620" DIAMETER	ON OC HOSES BETWEEN CYL FOR MASTER HOSES
NS	MC-141551	1	9600 SHIFT CABLE	JD PART NUMBER AH128356
NS	F-HCF-8M030E	4	FLHC-10.9 M8 X 1.25 X 30	RUBBER MOUNT
NS	F-HNF-8ME	4	FLHN-10.9 M8 X 1.25	RUBBER MOUNT
NS	F-HCF-10M030E	2	FLHC-10.9 M10 X 1.50 X 30	PUMP TO ANTI-ROTATION BRACKET
NS	F-HNF-10ME	2	FLHN-10.9 M10 X 1.50	PUMP TO ANTI-ROTATION BRACKET
NS	MC-135781	2	2" R/C HOSE CLAMP 3/8" HOLE	HEADER LIFT CYLINDER HOSES
NS	MC-135791	5	7/8" R/C HOSE CLAMP 3/8" HOLE	HEADER LIFT CYLINDER HOSES
NS	MC-135231	3	1/2" R/C HOSE CLAMP 3/8" HOLE	GREASE HOSE MNTS
NS	MC-135631	1	1-1/2" R/C HOSE CLAMP 3/8" HOLE	GREASE HOSE MNTS

Model 2960 Hillco Leveling System
For Serial Number 2960-1201 thru 2960-1299

10 PART NUMBER INDEX

PART NUMBER	PAGE NUMBER	PART NUMBER	PAGE NUMBER	PART NUMBER	PAGE NUMBER
D-020830DJC01	9-1	F-HC-24M070E	4-2	HA-E-6MF	8-14
D-020903CLA01	9-1	F-HC-24M110E	4-2	HA-J-8MF8MF	8-13
D-070522ADL01	9-1	F-HC5-04C12	7-2	HA-L-10FF10MF	8-14
EC-100557	7-2	F-HC8-06C20	8-8	HA-L-12FF12MF	8-14
EC-100692	7-2	F-HC8-07C44	8-2	HA-L-12MF16MO	8-14
EC-133281	7-4	F-HC8-08F20	2-6	HA-L-16FF12MF	8-12
EC-136211	7-2	F-HC8-12C240	3-4	HA-L-16MF16MO	8-13
EC-136221	7-2	F-HCF-05C08	8-4, 8-6	HA-L-2FP2MP	8-11
EC-136621	7-4	F-HCF-06M045F	5-2	HA-L-4MF4MO	8-14
EC-136631	7-4	F-HCF-10M020E	2-4, 3-4	HA-L-4MF6MO	8-13
EC-136651	7-4	F-HCF-10M020F	2-4, 2-4	HA-L-6MF4MO	8-13
EC-136661	7-4	F-HCF-10M020F	2-4	HA-L-6MF6MO	8-13
EC-136681	7-4	F-HCF-10M025E	2-4	HA-L-8FF8MF	8-13
EC-136711	7-4	F-HCF-10M025F	6-2	HA-L-8MF8MO	8-13, 8-14
EC-136731	7-4	F-HCF-10M030E	9-1	HA-L-8MO8MO	8-13
EC-136741	7-4	F-HCF-10M040E	8-8	HA-M-12MF12MF	8-14
EC-138781	7-2	F-HCF-12M025F	3-4	HA-M-16F	8-13
EC-138791	7-2	F-HCF-12M040E	2-4	HA-M-8F	8-13
EC-138801	7-2	F-HCF-12M080E	2-4	HA-NB-8FF	8-13
EC-139631	7-4	F-HCF-16M040E	2-4	HA-NJ-2FN	8-11
EC-139641	7-4	F-HCF-16M080E	3-4	HA-Q-8MF8MO	8-13
EC-140751	7-2	F-HCF-8M030E	9-1	HA-S-10FO12MO	8-14
EC-140761	7-2	F-HN-#10C	7-2	HA-S-10MF10MO	8-13, 8-14
EC-140771	7-2	F-HN8-07C	8-2	HA-S-10MF12MO	8-14
EC-140871	7-2	F-HNF-#10C	7-2	HA-S-12MF12MF	8-12
EC-140891	7-4	F-HNF-#6C	7-2	HA-S-12MF12MO	8-14
EC-141741	7-4	F-HNF-04C	2-4, 7-2	HA-S-12MO16MF	8-13
EC-141751	7-4	F-HNF-06MF	2-4	HA-S-2MN2FP	8-11
EC-141761	7-4	F-HNF-08MF	3-4, 6-2, 8-4, 8-6	HA-S-4FP10MO	8-14
EC-141771	7-4	F-HNF-10ME	2-4, 3-4, 8-8, 9-1	HA-S-4MF4MO	8-10
EC-141781	7-4	F-HNF-10MF	2-4, 3-4, 6-2, 7-2	HA-S-4MF8MO	8-10, 8-14
EC-141791	7-4	F-HNF-12MF	2-4	HA-T-16MF16MO	8-12
EC-141801	7-4	F-HNF-8ME	9-1	HA-T-4MF4MO	8-10
EC-141811	7-4	F-HNJ-05C	6-2	HA-T-6MF6MO	8-13
EC-141821	7-4	F-HNJ-12MF	2-4	HA-T-8MF8MO	8-13
EC-141831	7-2	F-HNN-08MF	9-1	HC-100706	2-2, 8-2
EC-142121	7-2	F-HNN-10MF	8-8	HC-101019	8-4
ET-ST-20#10	7-4	F-HNN-12MF	8-8	HC-101021	8-4
ET-ST-2004	7-4	F-HNS-12C	3-4	HC-101022	8-4
ET-ST-2005	7-4	F-HNS-12ME	2-4, 4-2, 6-2, 8-8	HC-101264	8-4
F-CB-10M030F	2-4	F-HNS-16ME	2-4, 3-4, 4-2	HC-101842	3-2, 8-2
F-CB-12M040F	2-4	F-HNS-20ME	5-2	HC-101843	8-2
F-EB-04C20	2-4	F-HNS-24ME	4-2	HC-102082	8-4
F-EYB-12M100F	8-8	F-HNSF-12ME	2-4	HC-103099	8-8
F-FHS-8M015E	2-4	F-LW-#10	8-4, 8-6	HC-103228	3-2, 8-2
F-FWH-06020	3-4	F-LW-04	7-2	HC-133151	8-8
F-FWH-08	2-4, 8-8	F-LW-05	6-2	HC-134191	2-2, 8-2
F-FWH-10	3-4, 4-2	F-LW-06A	8-8	HC-134201	8-2
F-HC-06M020F	2-4	F-LW-08A	2-6	HC-134251	8-2
F-HC-08M020F	8-4, 8-6	F-MB-10NR20	3-4	HC-134911	8-2
F-HC-08M025F	6-2	F-MB-14NR40	2-4	HC-135231	8-8
F-HC-08M035F	6-2	F-MB-18NR24	4-2	HC-135241	8-8
F-HC-08M090F	3-4	F-PCT-05X48	3-4	HC-135251	8-8
F-HC-08M120F	9-1	F-PHM-#10C16	7-2	HC-135761	8-11
F-HC-10M025F	3-4, 7-2	F-PHM-#10C28	7-2	HC-135881	8-11
F-HC-10M040F	3-4	F-PHM-#6C06	7-2	HC-136511	8-10
F-HC-10M110E	8-8	F-PHM-#6C12	7-2	HC-136541	8-10
F-HC-10M200E	8-8	F-PHM-04C24	7-2	HC-136551	8-10
F-HC-12M030F	6-2	F-PHM-04C36	7-2	HC-136561	8-10
F-HC-12M040E	8-8	F-PSL-04X48	3-4	HC-136571	8-10
F-HC-12M050E	2-4	F-SHC-#10C32	8-6	HC-136581	8-10
F-HC-12M050F	6-2	F-SHC-#10C52	8-4	HC-136591	8-10
F-HC-12M060F	8-8	F-SHC-04C28	8-6	HC-137061	8-8
F-HC-12M065F	6-2	F-SHC-10M070F	2-4	HC-137891	8-2
F-HC-12M080E	4-2	F-SSS-04F04	8-2	HC-137901	8-2
F-HC-16M050E	2-4	F-SSS-06C08	2-6	HC-138011	8-11
F-HC-16M060E	3-4	F-UDS-#7X06	3-4	HC-138691	8-2
F-HC-16M120E	2-4	HA-133131	8-11	HC-138861	8-4
F-HC-16M140E	4-2	HA-A-10MO	8-14	HC-139151	3-2, 8-2

Model 2960 Hillco Leveling System
For Serial Number 2960-1201 thru 2960-1299
PART NUMBER INDEX (CONTINUED)

PART NUMBER	PAGE NUMBER		PART NUMBER	PAGE NUMBER		PART NUMBER	PAGE NUMBER
HC-139501	9-1		LA-229292	8-4		LM-238341	2-2
HC-139511	9-1		LA-230551	3-2		LM-241101	7-2
HC-140291	8-4		LA-234952	2-2		LM-241122	7-2
HC-140291	8-6		LA-235371	8-8		LM-241271	6-2
HC-140361	8-2		LA-235381	8-8		LM-249861	2-2
HC-140411	8-4, 8-6		LA-236542	6-2		LM-252611	7-2
HC-140461	9-1		LA-236552	6-2		LM-252621	7-2
HC-141351	8-2		LA-236563	6-2		LM-254541	8-10
HC-141361	8-2		LA-238271	3-2		LM-254781	2-2
HC-141531	8-8		LA-238691	6-2		LM-255331	7-2
HC-142271	8-12		LA-238761	6-2		LM-255341	7-2
HC-142281	9-1		LA-238881	5-2		LM-260041	2-2
HC-142731	8-4		LA-240161	6-2		LP-103871	3-2
HC-142761	8-4		LA-243121	2-2		LP-228881	2-2
HC-142971	8-4, 8-6		LA-249062	7-6		LP-230241	3-2
HC-142981	8-6		LA-249611	2-2		LP-232162	2-2
HC-142991	8-6		LA-252462	7-6		LP-234572	3-2
HC-143001	8-6		LA-252711	8-6		LP-235311	8-8
HC-143041	8-6		LA-255621	7-6		LP-249321	3-2
HC-143071	8-6		LA-255631	7-6		LP-249871	2-2
HC-143971	8-4		LA-255821	7-2, 7-6		LP-255131	2-2
HC-143991	8-6		LA-256321	8-10		LS-212701	2-2
HC-144001	8-6		LA-257231	7-6		LS-234241	2-2
HC-145221	8-6		LA-257291	8-4		LS-235291	8-8
LA-130312	8-12		LA-257301	7-6		LS-244471	2-2, 2-6
LA-130343	8-10		LA-257311	7-6		LTA- 242281	7-6
LA-130371	8-11		LA-257321	7-6		LTA-242191	2-2
LA-130383	8-12		LA-257331	7-6		LTA-242271	7-6
LA-130483	8-12		LA-257351	7-2		LTA-242281	7-6
LA-130762	8-11		LA-257361	7-6		LTA-242291	7-6
LA-130771	8-11		LA-257371	7-2		LTA-243931	7-6
LA-133631	8-12		LA-259551	8-8		LTA-248901	7-6
LA-133672	8-11		LA-259661	7-2		LTA-248911	7-6
LA-133692	8-11		LA-259671	7-2		LTA-248921	7-6
LA-133912	8-11		LA-260051	2-2		LTP-241721	2-2
LA-133922	8-11		LA-262131	8-8		MC-100237	2-2
LA-133932	8-11		LA-263171	2-2		MC-100546	2-2
LA-133952	8-11		LL-133731	9-1		MC-100548	2-2
LA-135011	8-11		LL-138441	9-1		MC-101339	2-2
LA-135051	8-12		LL-142091	9-1		MC-103113	2-2
LA-135061	8-12		LL-143621	9-2		MC-133081	3-2
LA-135071	8-12		LL20-100782	9-1		MC-134321	8-8
LA-135081	8-12		LL20-100783	9-1		MC-134331	8-8
LA-135091	8-12		LL20-100784	9-1		MC-134341	8-8
LA-135611	8-11		LL20-100785	9-1		MC-134351	8-8
LA-136071	8-12		LL20-100786	9-1		MC-134361	8-8
LA-136181	8-11		LL20-100787	9-1		MC-134921	6-2
LA-136191	8-11		LL20-100788	9-1		MC-134931	6-2
LA-137881	8-11		LL20-100790	3-2, 9-1		MC-134941	6-2
LA-142331	8-12		LM-226532	2-2, 2-6		MC-135231	9-1
LA-142341	8-12		LM-226841	2-2		MC-135431	4-2
LA-142351	8-10		LM-228442	2-2		MC-135491	2-2
LA-142361	8-10		LM-229142	2-2		MC-135501	2-2
LA-143651	8-12		LM-229152	2-2		MC-135511	2-2
LA-145311	8-12		LM-229161	2-2		MC-135511	2-2
LA-145321	8-12		LM-229171	2-2		MC-135531	2-2
LA-145331	8-12		LM-229192	2-2		MC-135631	9-1
LA-145341	8-12		LM-229483	3-2		MC-135781	9-1
LA-145351	8-12		LM-230611	3-2		MC-135791	9-1
LA-228453	3-2		LM-230621	3-2		MC-136251	8-8
LA-228681	3-2		LM-230631	3-2		MC-136921	2-2, 2-6
LA-228702	4-2		LM-230641	3-2		MC-137521	9-1
LA-228721	4-2		LM-234101	4-2		MC-137531	9-1
LA-228762	4-2		LM-235281	8-8		MC-139241	2-2
LA-228811	5-2		LM-235821	8-8		MC-139341	2-2
LA-228893	2-2		LM-235831	8-8		MC-139351	2-2
LA-229022	2-2		LM-236053	6-2		MC-139361	2-2
LA-229051	2-2		LM-236232	2-2		MC-139371	2-2
LA-229071	2-2, 3-2		LM-236473	3-2, 7-2		MC-139941	7-2