

Model 2970S
Sidehill Leveling System
Parts Manual

SN 2970S-1035 thru 2970S-1075

D-060714ADL01A



TABLE OF CONTENTS

1 GENERAL INFORMATION	1-3
Serial Number Location	1-3
Text Format and Illustrations	1-3
Abbreviations.....	1-3
Right and Left Identification	1-3
Parts Orders	1-3
2 TRANSITION	2-1
Transition Fasteners.....	2-3
3 CARRIAGE	3-1
Carriage Fasteners.....	3-3
4 DROP AXLE	4-1
5 ELECTRICAL BOX AND CONNECTORS	5-1
Electrical Cables.....	5-3
6 HYDRAULICS	6-1
Hydraulic Manifold.....	6-3
Hydraulic Hoses	6-5
Hydraulic Adapters	6-6
7 MISCELLANEOUS	7-1
8 PART NUMBER INDEX	8-1
Part Number Index (Continued).....	8-2

Model 2970S Hillco Leveling System
For Serial Numbers 2970S-1035 thru 2970S-1075

Hillco Technologies, Inc.
107 1st Avenue
Nezperce Id. 83543

Fax	208.937.2280
Phone	208.937.2461
Toll Free	800.937.2461

www.hillcotechnologies.com

1 GENERAL INFORMATION

SERIAL NUMBER LOCATION

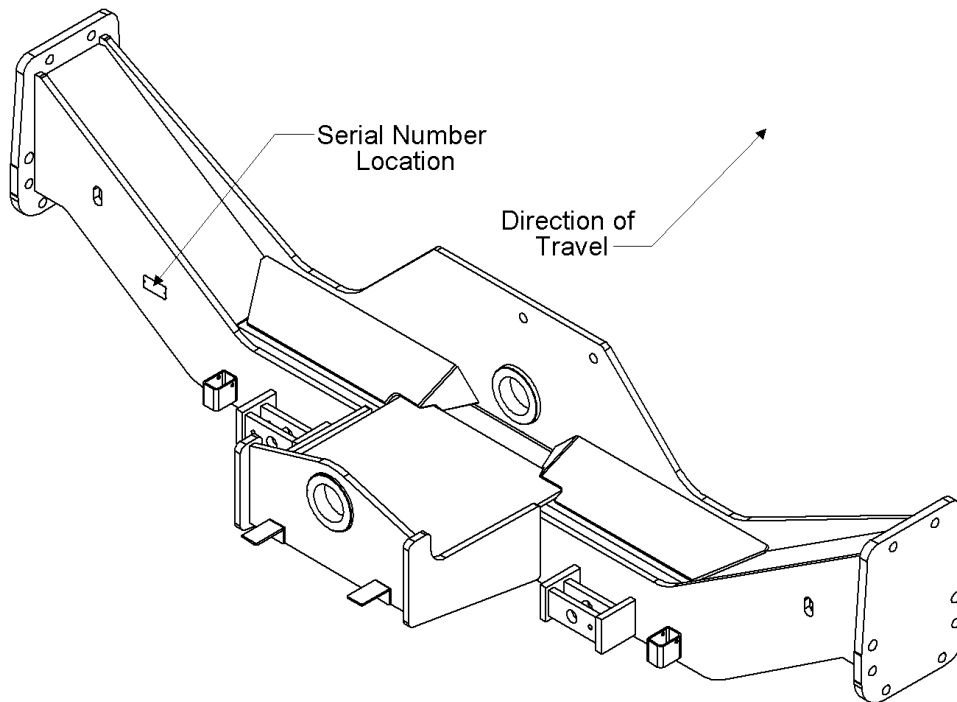

TEXT FORMAT AND ILLUSTRATIONS

The arrangement of this parts catalog is for easy identification of parts. All parts are illustrated in exploded views in proper relation to each other. Some diagrams refer to other pages for further information. Reference numbers used in the illustrations refer to line numbers in the part lists. The part lists appear to the right of all diagrams and correspond with those diagrams. Included in the part lists, along with the reference numbers are part numbers, part descriptions and the quantity of the part required per leveling system.

ABBREVIATIONS

SN "Serial Number" refers to the serial number given to each leveling system (by Hillco Technologies), as well as the serial number given to the combine (by the specific combine manufacturer) the leveling system is installed upon. This abbreviation is used interchangeably in both instances. Each model 2800 Leveling System uses the following serial number format: 2800-XXXX (sequential numbers).

ASM "Assembly" refers to a whole grouping of parts (usually shown in the diagram corresponding with the page where "ASM" is shown unless otherwise noted). Some assemblies have parts that are sold separately, however some must be purchased as a single unit. Hillco Product Specialists will be able to assist you with any questions.

NS "Not Shown" refers to a part that is not depicted in the illustration.

RIGHT AND LEFT IDENTIFICATION

The reference to right-hand and left-hand in this catalog is identified by the operator sitting in the operator's seat, looking toward the front of the machine (in normal forward travel).

PARTS ORDERS

Orders must specify product model, serial number, correct part number, complete description, quantity required, method of shipment, shipping address, and billing address.

2 TRANSITION

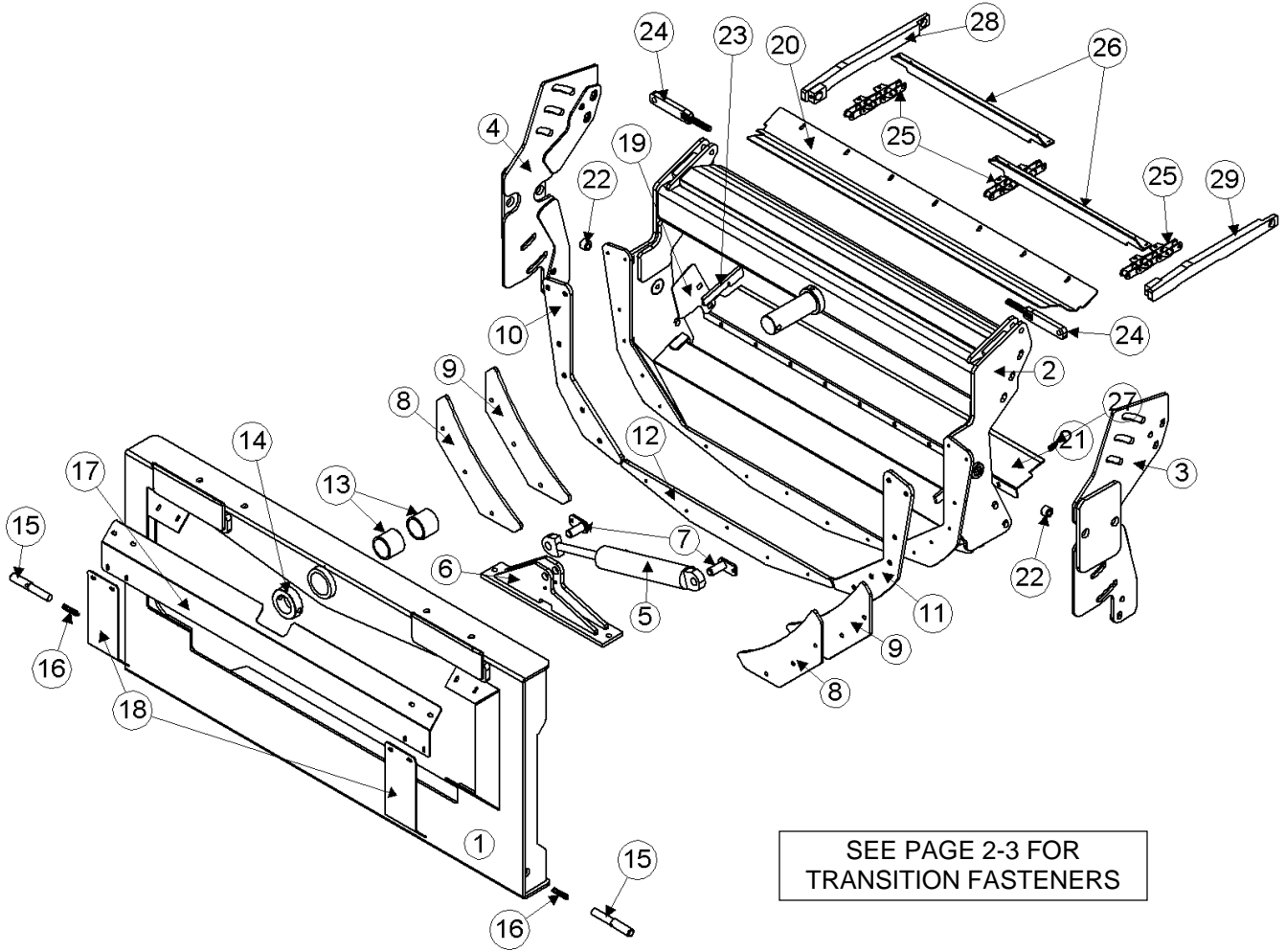

Model 2970S Hillco Leveling System
For Serial Numbers 2970S-1035 thru 2970S-1075

TRANSITION COMPONENTS				
REF.	PART NO.	QTY.	PART NAME	NOTES
1	LA-250163	1	TA ASM	
2	LA-250243	1	TT ASM, FRONT	
3	LA-260721	1	TT ASM, REAR LEFT	
4	LA-260771	1	TT ASM, REAR RIGHT	
5	HC-138581	1	CYLINDER, SLAVE	**SEE HYDRAULIC PAGE 6-2
6	LA-250713	1	TM ASM, SLAVE CYLINDER ROD MOUNT	
7	LA-253882	2	LM ASM, PIN	
8	LP-250551	2	TM UHMW, BACKING WEARPAD	
9	LM-250541	2	TM PLT, BACKING	
10	LM-250571	1	TM UHMW, RIGHT WEARPAD	
11	LM-250561	1	TM UHMW, LEFT WEARPAD	
12	LM-250581	1	TM UHMW, BOTTOM WEARPAD	
13	LTP-241721	2	BUSHING, PIVOT	
14	LM-226841	1	TM COLLAR, PIVOT	
15	LM-229192	2	TM ROD, LOCK	
16	MC-135531	2	TM SPRING, LOCK PIN	
17	LP-250522	1	TM PLT, TOP SHIELD	
18	LM-250533	2	TM PLT, LEFT & RIGHT SHIELD	
19	LP-260791	2	TM SHEET, ANTI-LEAK	
20	LP-260801	1	TM SHIELD, TOP	
21	LP-260811	1	TM PLATE, FLEX FLOOR	
22	LM-260821	2	TM BUSHING, PIVOT OUTER	
23	LP-261351	2	TM UHMW, THROAT SEAL	
24	LA-261021	2	TM ASM, DRAG LINK	
25	MC-143631	3	CA 557 FEEDER CHAIN, 6-PIN	LENGTHENS ORIGINAL FEEDER HOUSE CHAIN
26	MC-143461	2	FEEDER CHAIN SLAT, 96, 97, 9860 STS	SUBS TO JD PART NUMBER H206436
27	MC-143591	7	SPRING, COMPRESSION .703" OD X 1.09" LENGTH X .125" WIRE DIA	
28	LA-260851	1	TM ARM ASM, FEEDER DRUM RHT	
29	LA-260861	1	TM ARM ASM, FEEDER DRUM LFT	
NS	MC-141331	6	CONNECTING LINK, JD HD CHAIN	
NS	MC-142261	6	S-WIRE KEEPER PINS	SUBS TO JD PART NUMBER H204865

Model 2970S Hillco Leveling System
For Serial Numbers 2970S-1035 thru 2970S-1075

TRANSITION FASTENERS

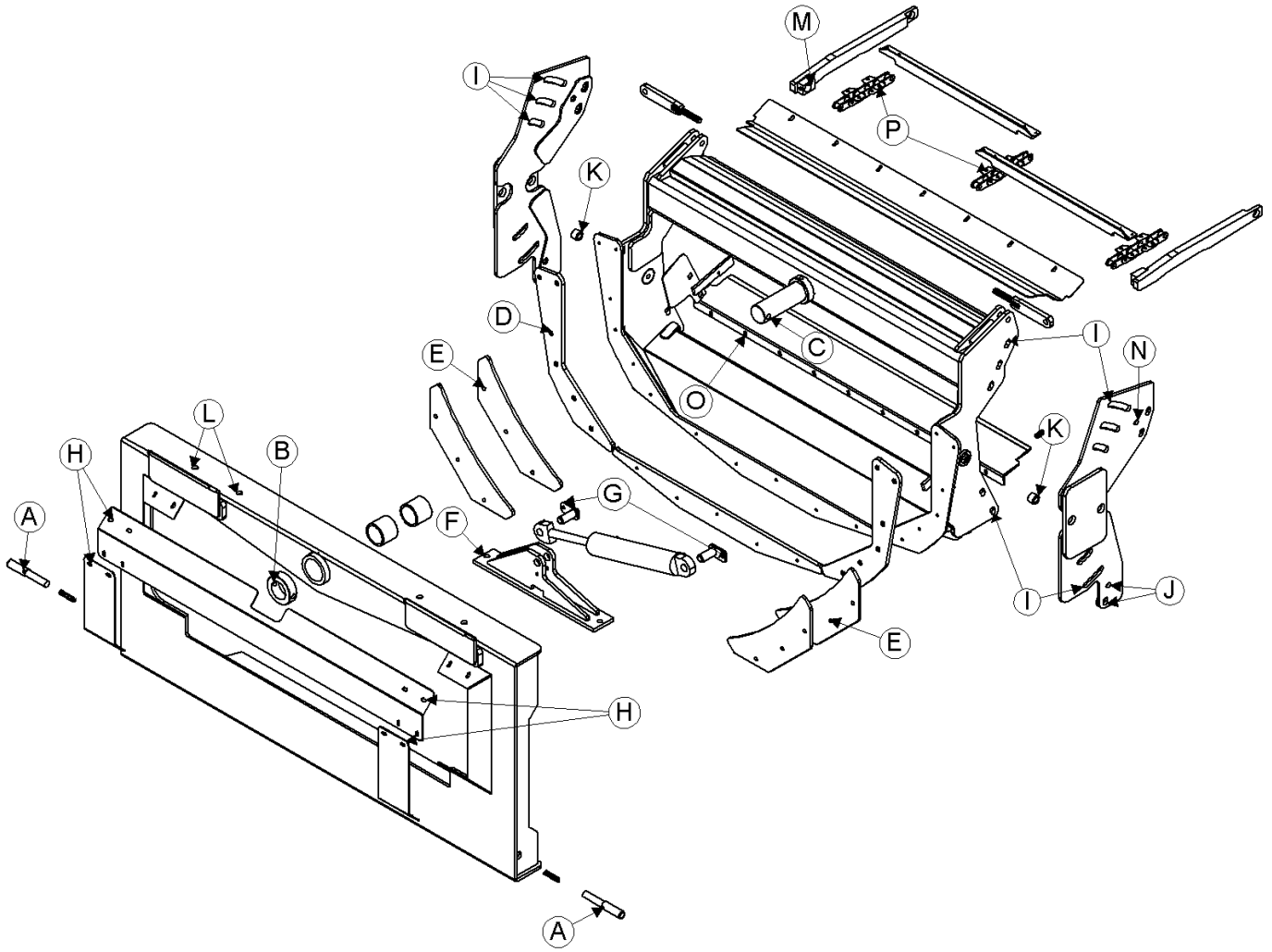

Model 2970S Hillco Leveling System
For Serial Numbers 2970S-1035 thru 2970S-1075

TRANSITION FASTENERS				
REF.	PART NO.	QTY.	PART NAME	NOTES
A	F-HC-10M070E	2	HC-10.9 M10 X 1.5 X 70	HEADER LOCK PINS
B	F-HC-16M120E	1	HC-10.9 M16 X 2.00 X 120	MAIN PIVOT PIN COLLAR
B	F-HNS-16ME	1	HN-10.9 M16 X 2.00 STV	MAIN PIVOT PIN COLLAR
C	F-MB-14NR40	4	MACH BUSH 14 GA NR 2-1/2 ID	MAIN PIVOT PIN
D	F-FHS-8M030E	17	FHSC-10.9 M8 X 1.25 X 30	UHMW FACE PLT
D	F-HNS-8ME	17	HN-10.9 M8 X 1.25 STV	UHMW FACE PLT
E	F-HCF-12M040E	6	FLHC-10.9 M12 X 1.75 X 40	BACKING PLATES
F	F-HNF-16ME	3	FLHN-10.9 M16 X 2.00	SL CYL ROD MNT
F	F-HCF-16M040E	3	FLHC-10.9 M16 X 2.00 X 40	SL CYL ROD MNT
G	F-HCF-10M035E	2	FLHC-10.9 M10 X 1.50 X 35	SLAVE CYLINDER MNT PIN
G	F-HNS-10ME	2	HN-10.9 M10 X 1.50 STV	SLAVE CYLINDER MNT PIN
H	F-HCF-8M020E	12	FLHC- 10.9 M8 X 1.25 X 20	SHIELDS
H	F-HNF-08ME	12	FLHN-10.9 M8 X 1.25	SHIELDS
I	F-CB-16M050E	10	CARR-10.9 M16 X 2.00 X 50	CONNECTS FRONT & REAR THROATS
I	F-HNF-16ME	10	FLHN-10.9 M16 X 2.00	CONNECTS FRONT & REAR THROATS
I	MC-143641	10	FW 17.5 X 56 X 5MM	CONNECTS FRONT & REAR THROATS
J	F-CB-16M050E	4	CARR-10.9 M16 X 2.00 X 50	REAR THROAT TO FEEDERHOUSE
K	F-HCF-16M040E	2	FLHC-10.9 M16 X 2.00 X 40	TRANSITION PIVOT BOLTS
K	MC-143641	2	FW 17.5 X 56 X 5MM	TRANSITION PIVOT BOLTS
L	F-HNF-16ME	4	FLHN-10.9 M16 X 2.00 NUT	HEADER TOP SPACER PLATES
M	F-PCT-02X16	2	PIN COTTER 1/8 X 1	PINS FOR FEEDER DRUM ARMS
N	F-HC-16M050E	2	HC-10.9 M16 X 2.0 X 50	DRILLED HOLE TRANSITION TO FEEDERHOUSE
N	F-HNF-16ME	2	FLHN-10.9 M16 X 2.00	DRILLED HOLE TRANSITION TO FEEDERHOUSE
O	F-CB-10M050F	7	CARR-8.8 M10 X 1.50 X 50	FLOOR HINGE
O	F-HNN-10MF	7	HN-8.8 M10 X 1.50 NYLOCK	FLOOR HINGE
P	F-HC-8M020E	8	HC-10.9 M8 X 1.25 X 20	FEEDER CHAIN SLATS TO CHAIN - JD PART NUMBER 19M7881
P	F-HNS-8ME	8	HN-10.9 M8 X 1.25 STV	FEEDER CHAIN SLATS TO CHAIN - JD PART NUMBER E64256

3 CARRIAGE

SEE PAGE 3-3 FOR
CARRIAGE FASTENERS

FRONT VIEW

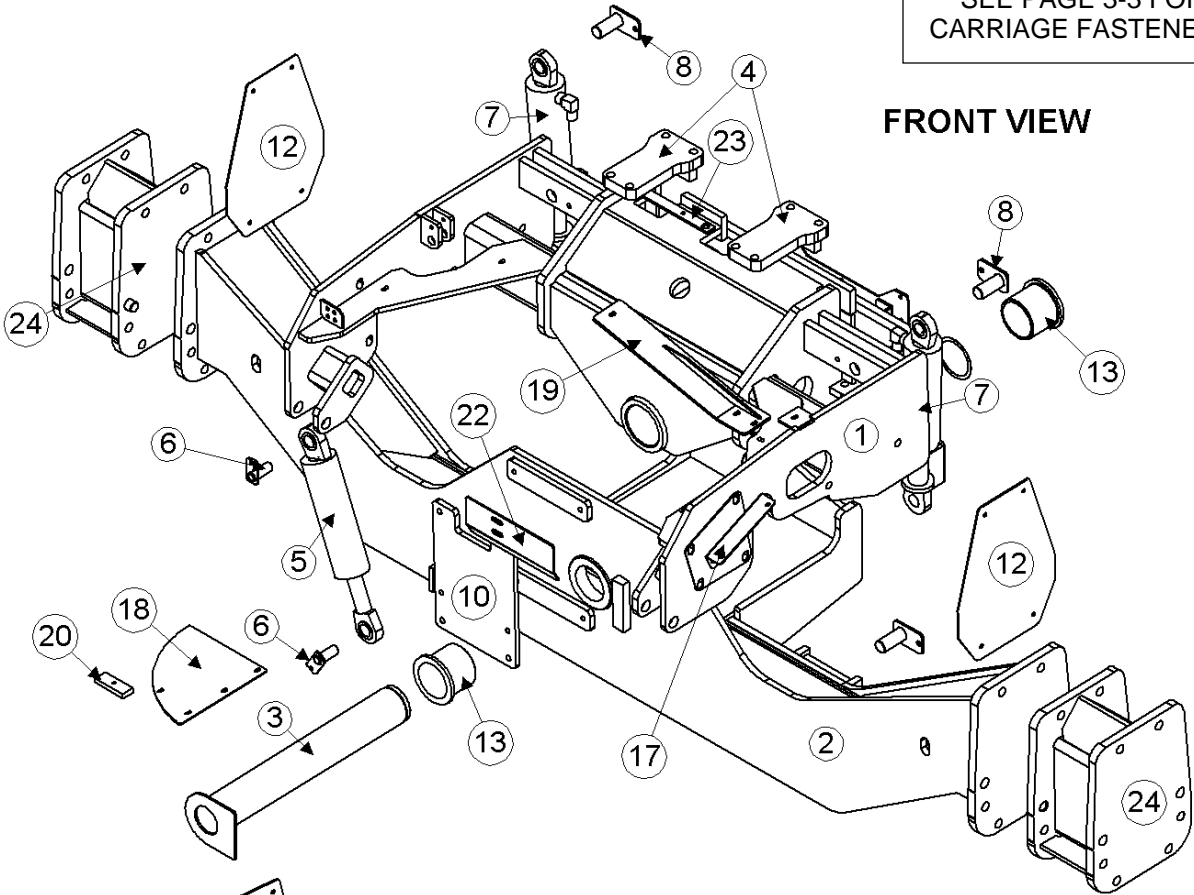

REAR VIEW

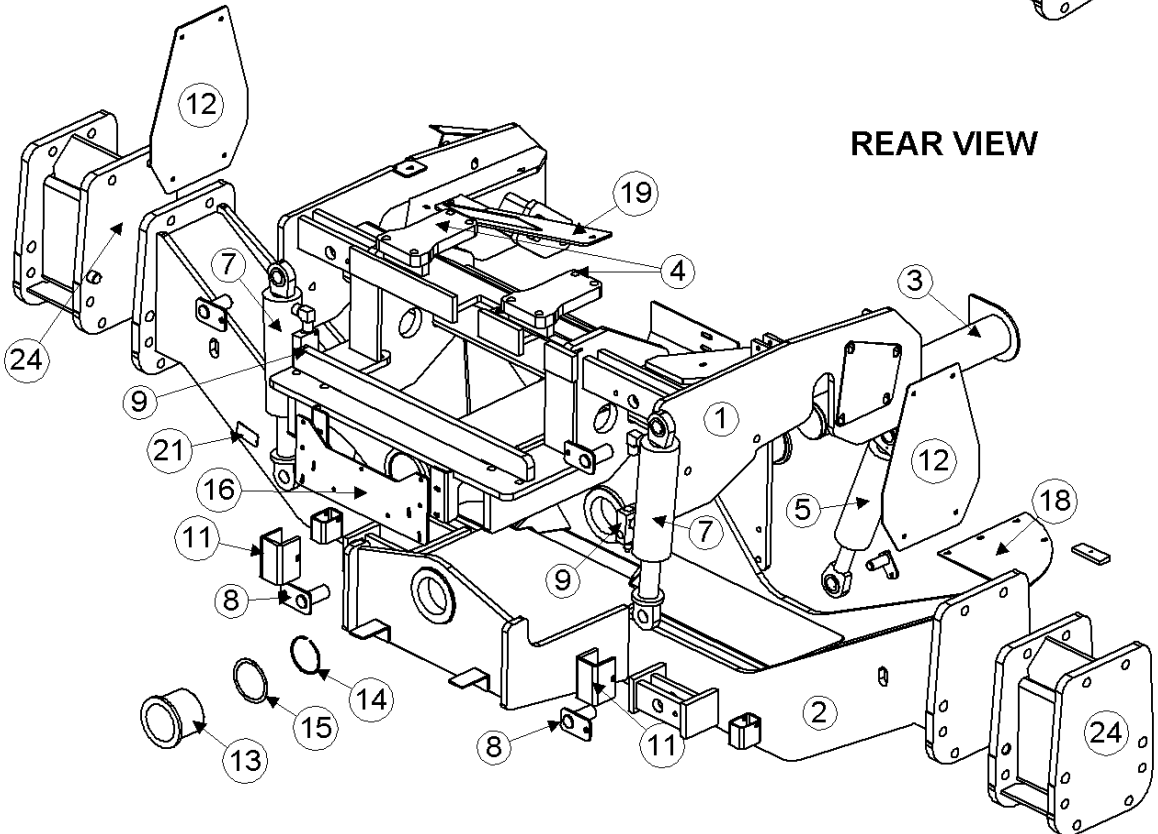

Model 2970S Hillco Leveling System
For Serial Numbers 2970S-1035 thru 2970S-1075

CARRIAGE COMPONENTS				
REF.	PART NO.	QTY.	PART NAME	NOTES
1	LA-247284	1	CO ASM	
2	LA-247093	1	CU ASM, WIDE	FOR COMBINES WITH DUAL TIRES
NS	LA-262021	1	CU ASM, NARROW	FOR COMBINES WITH SINGLE TIRES
3	LA-247482	1	CM ASM, MAIN PVT PIN	
4	LA-235711	2	CM PLATE ASM, TOP	
5	HC-140341	1	CYLINDER, MASTER	**SEE HYDRAULICS PAGE 6-2
6	LA-253882	2	LM ASM, PIN	
7	HC-140312	2	CYLINDER, MAIN LEVELING	**SEE HYDRAULICS PAGE 6-2
8	LA-230552	4	CM PIN ASM, MAIN CYLINDER	
9	HC-138901	2	VALVE, COUNTER BALANCE	**SEE HYDRAULICS PAGE 6-2
10	LM-260591	1	CM PLATE, TRANSMISSION MOUNT	
11	LP-252241	2	LM PLT, CYLINDER STOP	
12	LP-230241	2	CM CAP, AXLE	
13	LP-247961	2	CM BUSHING, PIVOT	
14	MC-138651	1	SNAP RING 4"	
15	MC-138641	1-4	WASHER 4.016ID X 4.764OD X .048	
16	LP-261431	1	EM PLATE, ELECTRICAL MOUNT	
17	LP-261531	1	HM SUPPORT, HDR LIFT CYL HOSE	
18	LP-261121	1	HM TABLE, HYDRO HOSE	
19	LA-261371	1	HM MOUNT ASM, HYDRO CLAMP	
20	LM-261091	3	HM FLAT, CLAMP SPACER	
21	LA-255961	1	TAG, SERIAL NUMBER	
22	LP-258221	1	SHIELD, SHIFT CABLE	
23	LM-248781	1	LM FLT, BRAKELINE BRKT	
REQUIRED ON 9660, 9760, & 9860 STS COMBINES THAT ARE EQUIPPED WITH CU ASM, NARROW (P/N LA-262021) IF COMBINE NEEDS TO BE CONVERTED TO DUAL TIRES				
24	LA-253131	2	LM ASM, 9.25 AXLE EXTENSION	
MISCELLANEOUS CARRIAGE COMPONENTS AND FASTENERS				
NS	MC-142921	2	EMERGENCY BRAKE CABLE	
NS	MC-141551	1	CABLE, SHIFT	SUBS TO JOHN DEERE CABLE PART NUMBER AH128356
NS	F-HNN-8MF	2	HN-8.8 M8X1.25 NYLOCK	NUT, FOR BRAKE CABLE

Model 2970S Hillco Leveling System
For Serial Numbers 2970S-1035 thru 2970S-1075

CARRIAGE FASTENERS

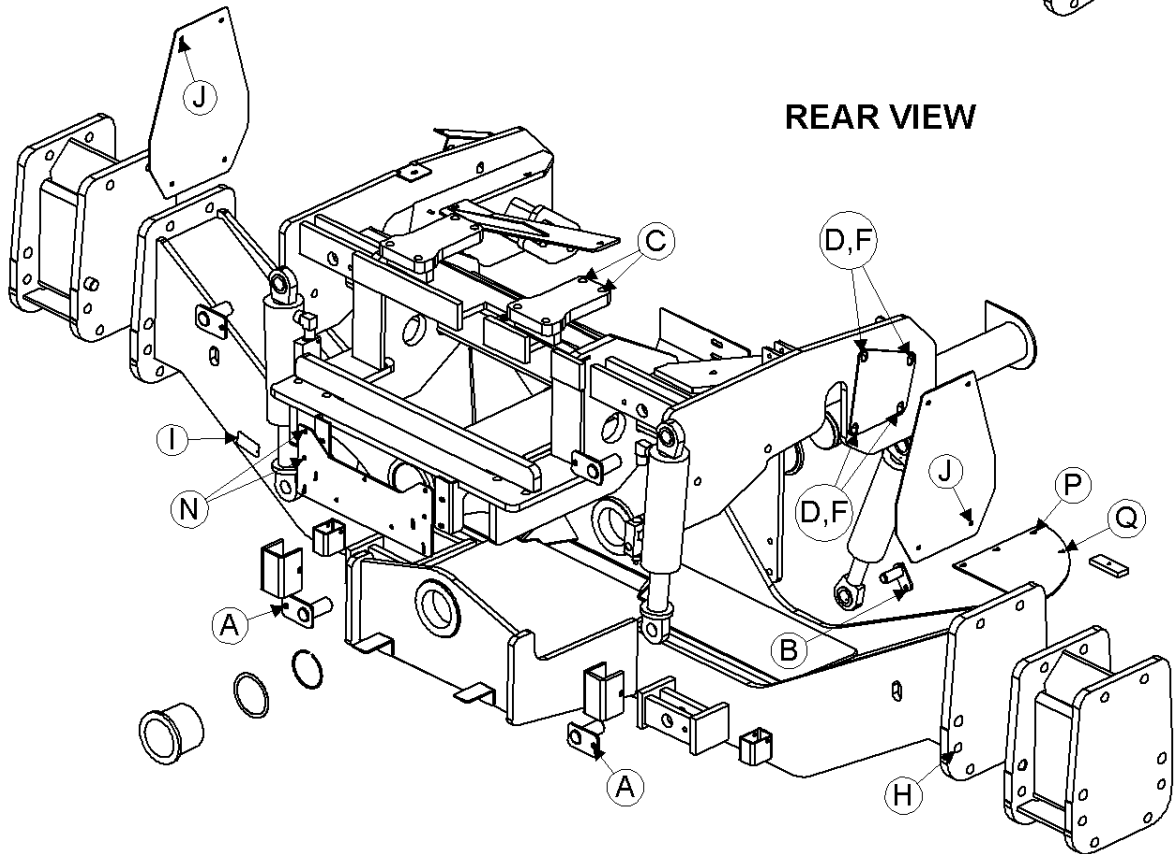
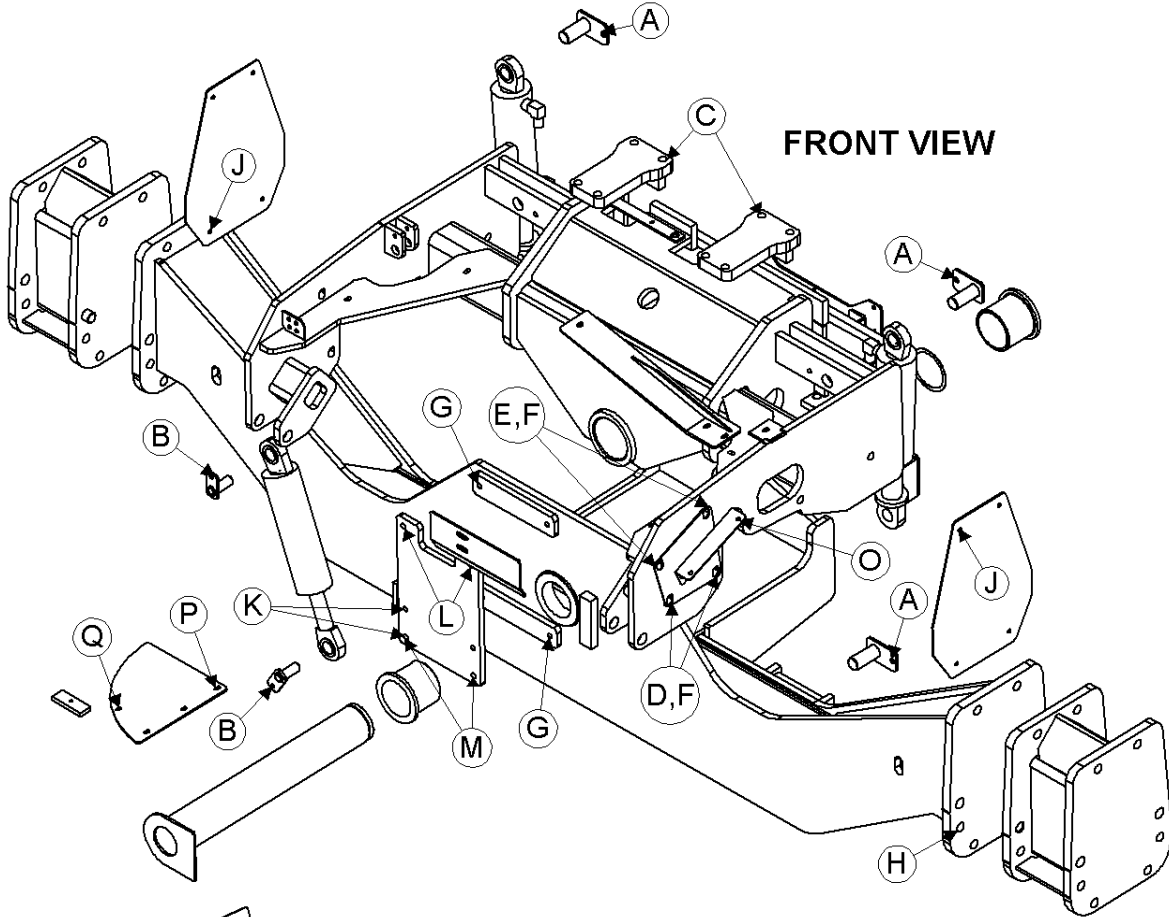

Model 2970S Hillco Leveling System
For Serial Numbers 2970S-1035 thru 2970S-1075

CARRIAGE FASTENERS				
REF.	PART NO.	QTY.	PART NAME	NOTES
A	F-HCF-12M040F	4	FLHC-8.8 M12 X 1.75 X 40	LEVELING CYL MNT PIN
A	F-HNS-12ME	4	HN-10.9 M12 X 1.75 STOVER	LEVELING CYL MNT PIN
B	F-HCF-10M035E	2	FLHC-10.9 M10 X 1.50 X 35	MASTER CYL MNT PIN
B	F-HNS-10ME	2	HN-10.9 M10 X 1.5 STOVER	MASTER CYL MNT PIN
C	F-HC8-12C240	8	HC8 3/4-10 X 15	OVERCARRIAGE CLAMP
C	F-HNS-12C	8	HN8 3/4-10 STOVER	OVERCARRIAGE CLAMP
D	F-HC-16M110E	6	HC-10.9 M16 X 2.00 X 110	OVERCARRIAGE FRONT RIGHT & BOTTOM LEFT
E	F-HC-16M120E	2	HC-10.9 M16 X 2.00 X 120	OVERCARRIAGE FRONT LEFT TOP
F	F-FWH-10	8	FW 5/8 HD	OVERCARRIAGE FRONT
G	F-HNF-16ME	4	FLHN-10.9 M16 X 2.00	BTM & TOP TRANSMISSION MNT HOLES
H	F-SHC-24M080E	4	SHCS 10.9-M24 X 3 X 80 ZINC	FINAL MOUNT
I	F-UDS-#7X06	2	SCREW, U-DRIVE #7 X 3/8	SERIAL NUMBER PLATE
J	F-HCF-10M040F	8	FLHC-8.8 M10 X 1.50 X 40	ORIGINAL AXLE COVER
J	F-HNF-10MF	8	FLHN-8.8 M10 X 1.50	ORIGINAL AXLE COVER
J	F-FWF-06020	8	3/8 FW FENDER X 1-1/4	ORIGINAL AXLE COVER
K	MC-143711	4	STUD, DOUBLE-ENDED-10.9 M16 X 2.00 X 75 20MM ONE END - 41MM OTHER END	LOWER TRANSMISSION MOUNTING HOLES ON PLATE & UC
L	MC-143721	2	STUD, DOUBLE-ENDED-10.9 M16 X 2.00 X 90 18MM ONE END - 56MM OTHER END	UPPER TRANSMISSION MOUNTING HOLES ON UC
M	F-HNF-16ME	2	FLHN-10.9 M16 X 2.00	LOWER STUDS THAT HOLD PLATE TO UC
N	F-HNF-08ME	4	FLHN-10.9 M8 X 1.25	ELECTRICAL BOX TO OC
N	F-HCF-8M020E	4	FLHC- 10.9 M8 X 1.25 X 20	ELECTRICAL BOX TO OC
O	F-HCF-8M020E	3	FLHC-10.9 M8 X 1.25 X 20	HOSE CLAMPS FOR HDR LIFT CYL HOSES
O	F-HNF-8ME	3	FLHN-10.9 M8 X 1.25	HOSE CLAMPS FOR HDR LIFT CYL HOSES
P	F-HCF-8M020E	2	FLHC-10.9 M8 X 1.25 X 20	HYDRO HOSE TABLE TO TRANSMISSION
Q	F-HCF-8M020E	1	FLHC-10.9 M8 X 1.25 X 20	CASE DRAIN HOSE
Q	F-HNF-08ME	2	FLHN-10.9 M8 X 1.25	CASE DRAIN HOSE

Model 2970S Hillco Leveling System
For Serial Numbers 2970S-1035 thru 2970S-1075

4 DROP AXLE

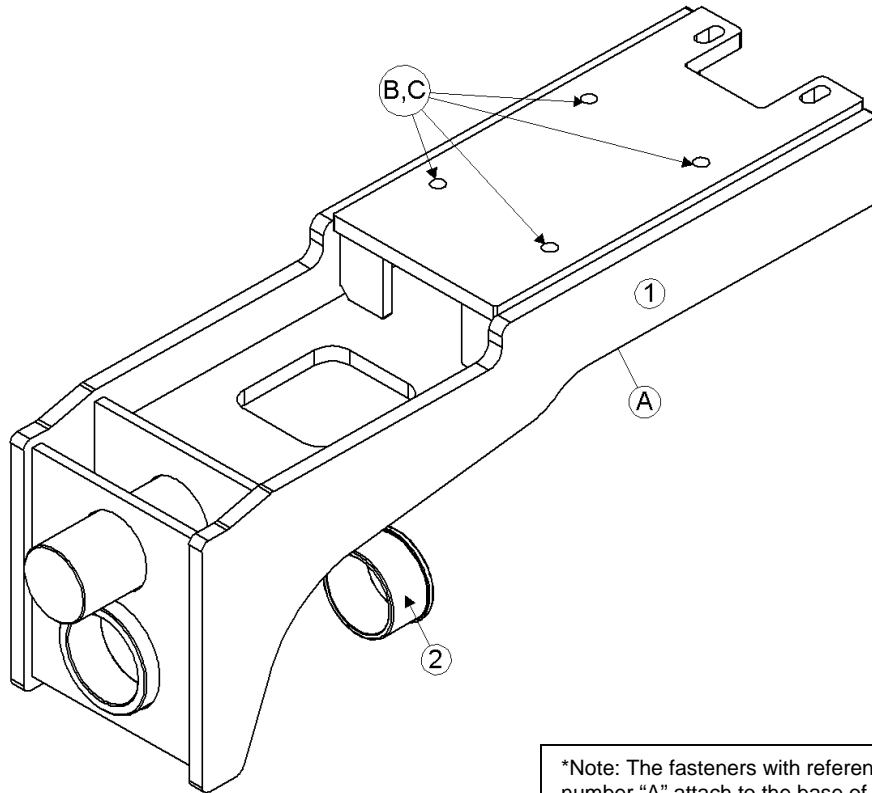

*Note: The fasteners with reference number "A" attach to the base of the Drop Axle Assembly (LA-246702), however, they cannot be shown in this view. The leader is pointing to the general area where they will be found.

Model 2970S Hillco Leveling System
For Serial Numbers 2970S-1035 thru 2970S-1075

DROP AXLE COMPONENTS				
REF.	PART NO.	QTY.	PART NAME	DESCRIPTION
1	LA-246702	1	DA ASM	
2	LP-235092	1	LM BUSHING, DA PIVOT	
DROP AXLE FASTENERS				
REF.	PART NO.	QTY.	PART NAME	WHERE USED
A	F-HC-16M250E	4	HC-10.9 M16 X 2.00 X 250	
A	F-HNS-16ME	4	HN-10.9 M16 X 2.00 STV	
B	F-HC-16M060E	6	HC-10.9 M16 X 2.00 X 60	
B	F-HNS-16ME	6	HN-10.9 M16 X 2.00 STV	
C	F-FWH-10	10	FW 5/8 HD	

5 ELECTRICAL BOX AND CONNECTORS

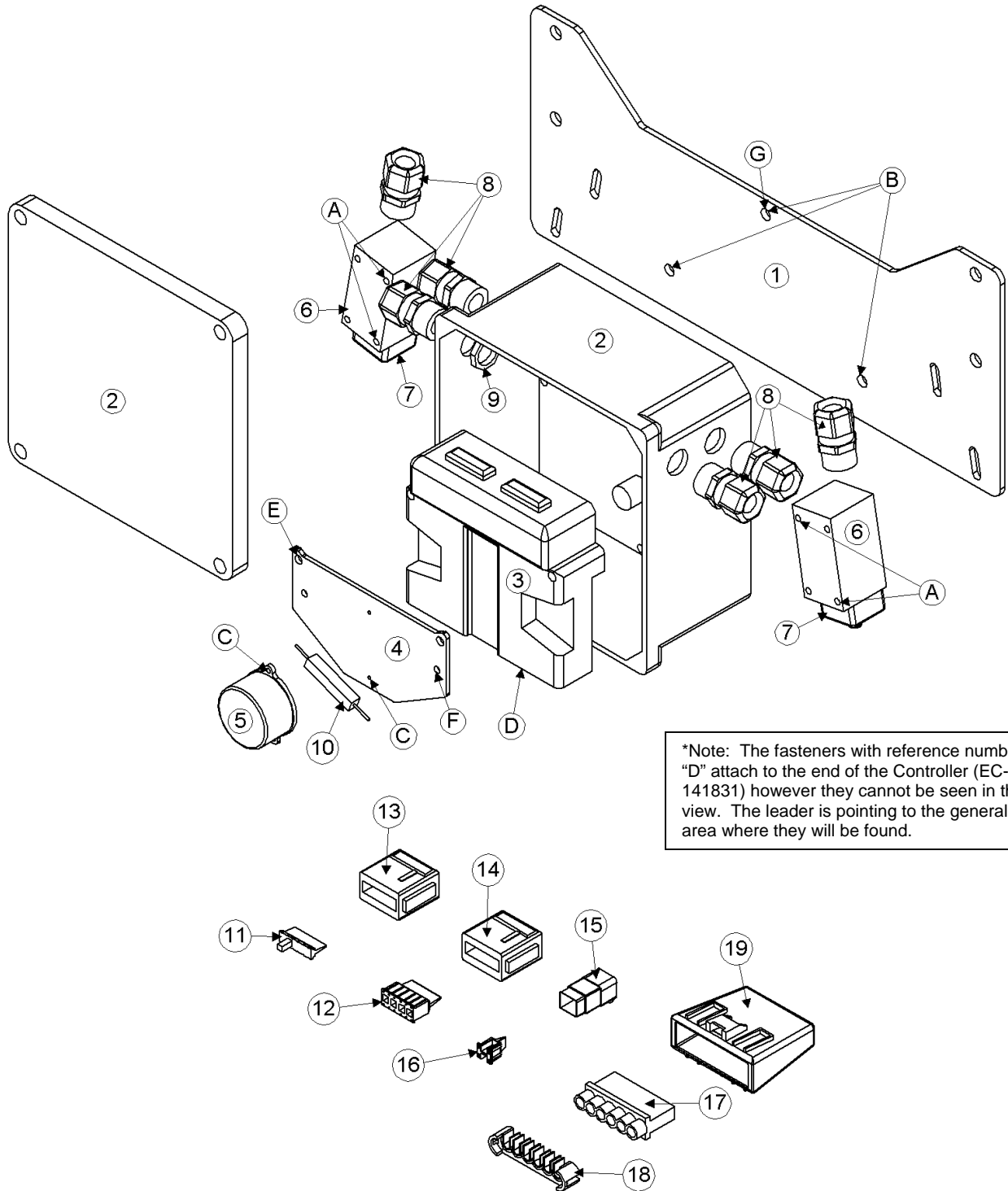

*Note: The fasteners with reference number "D" attach to the end of the Controller (EC-141831) however they cannot be seen in this view. The leader is pointing to the general area where they will be found.

**Note: Line item numbers '5' and '10' refer to complete assemblies. The complete assemblies are not shown in this diagram. See page 5-3 for a picture of the complete assemblies.

Model 2970S Hillco Leveling System
For Serial Numbers 2970S-1035 thru 2970S-1075

ELECTRICAL COMPONENTS				
REF.	PART NO.	QTY.	PART NAME	NOTES
FOR ALL COMBINES				
1	LP-261431	1	EM PLATE, ELECTRICAL MOUNT	
2	LM-255341	1	EM BOX, CONTROLLER MOUNT	
3	EC-141831	1	CONTROLLER	
4	LM-255331	1	EM SHT, CLINOMETER MOUNT	
5	LA-255821	1	EM ASM, CLINOMETER	*SEE NOTE BELOW DIAGRAM
6	EC-100557	2	BODY, LIMIT SWITCH	
7	EC-100692	2	HEAD, LIMIT SWITCH STRAIGHT PLUNGER	
8	EC-138781	6	STRAIN RELIEF, NYLON, BLK, 1/2 NPT	
9	EC-142121	4	STRAIN RELIEF NUT, 1/2" NYLON, BLK	
FOR COMBINES WHICH FALL WITHIN THE FOLLOWING SERIAL NUMBER BREAKS:				
9650STS (695501-); 9750STS (695601-); 9660STS (705501-); 9760STS (705601-); 9860STS (705701-)				
10	LA-255621	1	EM CABLE ASM, RESISTOR	*SEE NOTE BELOW DIAGRAM
ELECTRICAL FASTENERS				
REF.	PART NO.	QTY.	PART NAME	NOTS
A	F-PHM-#10C28	4	PHMS 10-24 X 1-3/4	LIMIT SWITCH MNT
A	F-HNF-#10C	4	HN 10-24, FLNG SERR	LIMIT SWITCH MNT
B	F-HC5-04C12	3	HC5 1/4-20 X 3/4	PVC BOX MOUNTING
B	F-LW-04	3	LW 1/4	PVC BOX MOUNTING
C	F-PHM-#6C06	2	PHMS #6-32 X 3/8	CLINOMETER MNT TO ALUMINUM PLT
D	F-PHM-04C24	2	PHMS 1/4-20 X 1-1/2	CONTROLLER TO PVC BOX
D	F-HNF-04C	2	FLHN 1/4-20 SERR.	CONTROLLER TO PVC BOX
E	F-PHM-04C36	2	PHMS 1/4-20 X 2-1/4	GROUNDING PLATE MOUNTING
E	F-HNF-04C	2	FLHN 1/4-20 SERR.	GROUNDING PLATE MOUNTING
F	F-PHM-#10C16	2	PHMS 10-24 X 3/4	GROUNDING PLATE GROUND
F	F-HNF-#10C	2	HN5 10-24, FLNG SERR	GROUNDING PLATE GROUND
G	F-LWE-04	1	LW 1/4, EXTERNAL STAR	MAIN GROUND
ELECTRICAL CONNECTORS AND MISCELLANEOUS				
REF.	PART NO.	QTY.	PART NAME	NOTES
11	EC-143271	1	DTM SERIES, 12-PIN WEDGE	
12	EC-141741	3	DTM SERIES, 12-SOCKET WEDGE	
13	EC-141761	1	DTM SERIES, 12-SOCKET PLUG GRAY	
14	EC-141751	2	DTM SERIES, 12-SOCKET PLUG BLACK	
15	EC-141791	1	DTM SERIES, 4-SOCKET PLUG	
16	EC-141801	1	DTM SERIES, 4-SOCKET WEDGE	
17	EC-143301	1	BODY, SPLICE PACK	
18	EC-143311	1	TPA	
19	EC-143321	1	CAP, EXTENDED, BLACK	
NS	EC-143281	3	PLUG, CAVITY	
NS	EC-136631	4	SEAL, GREEN	
NS	EC-140861	2	SEAL, RED	
NS	EC-136701	5	PIN, AMP	
NS	EC-136711	1	AMP SOCKET	
NS	EC-100164	1	PIN, ELECTRICAL	
NS	EC-100165	2	SOCKET, SIZE 16 DEUTSCH	
NS	EC-133281	2	DIODE, 6 AMP, 50 PIV, SILICON	
NS	EC-139641	4	CONNECTOR, PARALLEL, 16-14 GA	
NS	EC-139631	3	CONNECTOR, PARALLEL, 12-10 GA	
NS	EC-140781	1	BULB, JD# AA2753	MAX LEVEL LIGHT IN STEERING COLUMN
NS	EC-140801	4	TERMINAL, JD# R104701	
NS	EC-140841	4	TERMINAL, FEMALE, MP 280 SERIES	
NS	EC-140851	2	TERMINAL	
NS	EC-143811	1	TERMINAL, MALE, MP 280 SERIES	
NS	ET-ST-20#10	8	TERMINAL, RING, #10, 20 GA., NON-INSULATED	
NS	ET-ST-2004	1	TERMINAL, RING, NON-INS, 1/4, 20 GA	
NS	EC-143421	1	DTM SERIES, 12-PIN RECEPTACLE W/ A-KEY, FLANGE MNT	
NS	EC-141771	34	DTM SERIES, SOCKET CONTACT, STAMPED	
NS	EC-141781	12	DTM SERIES, PIN CONTACT, STAMPED	

ELECTRICAL CABLES



#1 LA-255631
EM CABLE ASM, LIMIT



#2 LA-255821
EM ASM,
CLINOMETER



#3 LA-252462
EM CABLE ASM, MAX
LEVEL LIGHT



#4 LA-255642
EM ASM, BOX TO VALVE



#5 LA-260361
EM CABLE ASM,
MANIFOLD



#6 LA-260251
EM ALL CABLE ASM, BOX TO VALVE



#8 LA-260231
EM ALL CABLE ASM, BOX TO VALVE



#7 LA-255721
EM ALL CABLE ASM, CAB TO BOX, EARLY



#10 LA-255621
EM CABLE ASM, RESISTOR



#9 LA-255731
EM ALL CABLE ASM, CAB TO BOX, LATE

Model 2970S Hillco Leveling System
For Serial Numbers 2970S-1035 thru 2970S-1075

ELECTRICAL CABLE ASSEMBLIES				
REF.	PART NO.	QTY.	PART NAME	DESCRIPTION
ALL COMBINES				
1	LA-255631	2	EM CABLE ASM, LIMIT SWITCH	
2	LA-255821	1	EM CABLE ASM, CLINOMETER	
3	LA-252462	1	EM CABLE ASM, MAX LEVEL LIGHT	
4	LA-255642	1	EM CABLE ASM, BOX TO VALVE	
NS	LA-261691	1	EM ASM, DIAGNOSTIC CONNECTION	
5	LA-260361	1	EM CABLE ASM, MANIFOLD	
..	LA-261141	1	EM CABLE ASM, LEVEL LEFT	INCLUDED IN LA-260361
..	LA-261151	1	EM CABLE ASM, LEVEL RIGHT	INCLUDED IN LA-260361
..	LA-261161	1	EM CABLE ASM, TRIM LEFT	INCLUDED IN LA-260361
..	LA-261171	1	EM CABLE ASM, TRIM RIGHT	INCLUDED IN LA-260361
..	LA-261481	1	EM CABLE ASM, DUMP VALVE	INCLUDED IN LA-260361
..	LA-261661	1	EM ASM, TRIM DIODE	INCLUDED IN LA-260361
FOR COMBINES WHICH FALL WITHIN THE FOLLOWING SERIAL NUMBER BREAKS:				
9650STS (ALL); 9750STS (ALL); 9660STS (705501-715400); 9760STS (705601-715500); 9860STS (705701-715600)				
6	LA-260251	1	EM ALL CABLE ASM, BOX TO VALVE	
..	LA-255642	1	EM CABLE ASM, BOX TO VALVE	INCLUDED IN LA-260251
..	LA-260241	1	EM CABLE ASM, TRIM SIGNAL	INCLUDED IN LA-260251
FOR COMBINES WHICH FALL WITHIN THE FOLLOWING SERIAL NUMBER BREAKS:				
9650STS (-695500); 9750STS (-695600)				
7	LA-255721	1	EM ALL CABLE ASM, CAB TO BOX, EARLY	
..	LA-252482	1	EM CABLE ASM, CAB TO BOX	INCLUDED IN LA-255721
..	LA-252462	1	EM CABLE ASM, MAX LEVEL LIGHT	INCLUDED IN LA-255721
FOR COMBINES WHICH FALL WITHIN THE FOLLOWING SERIAL NUMBER BREAKS:				
9660 STS (715401-); 9760 STS (715501-); 9860 STS (715601-)				
8	LA-260231	1	EM ALL CABLE ASM, BOX TO VALVE	
..	LA-255642	1	EM CABLE ASM, BOX TO VALVE	INCLUDED IN LA-260231
..	LA-260221	1	EM CABLE ASM, TRIM SIGNAL	INCLUDED IN LA-260231
FOR COMBINES WHICH FALL WITHIN THE FOLLOWING SERIAL NUMBER BREAKS:				
9650STS (695501-); 9750STS (695601-); 9660STS (705501-); 9760STS (705601-); 9860STS (705701-)				
9	LA-255731	1	EM ALL CABLE ASM, CAB TO BOX, LATE	
10	LA-255621	1	EM CABLE ASM, RESISTOR	INCLUDED IN LA-255731
..	LA-252472	1	EM CABLE ASM, CAB TO BOX	INCLUDED IN LA-255731
..	LA-252462	1	EM CABLE ASM, MAX LEVEL LIGHT	INCLUDED IN LA-255731

6 HYDRAULICS

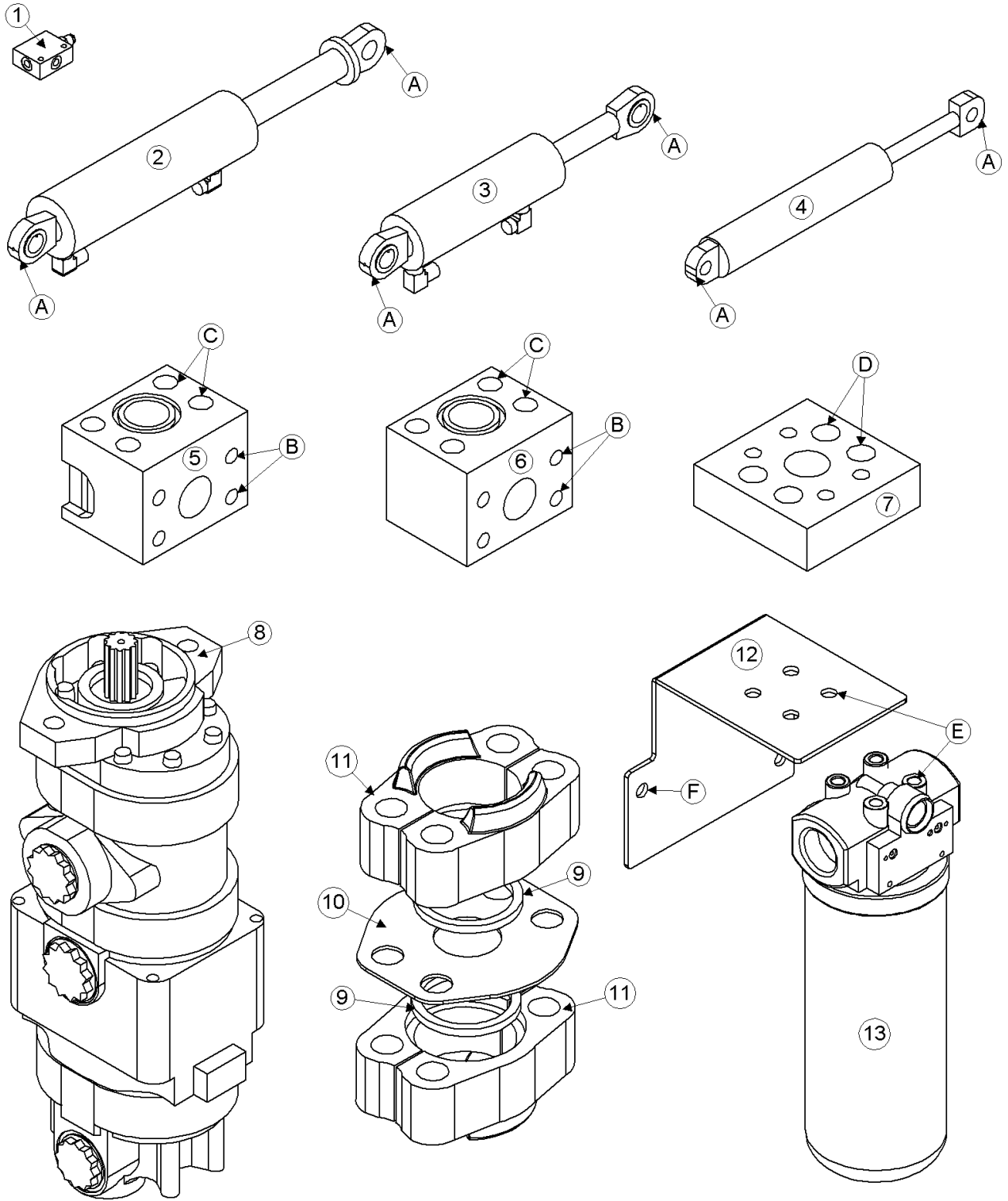

Model 2970S Hillco Leveling System
For Serial Numbers 2970S-1035 thru 2970S-1075

HYDRAULIC COMPONENTS & FASTENERS				
REF.	PART NO.	QTY.	PART NAME	NOTES
1	HC-138901	2	VALVE, COUNTER BALANCE	
..	HC-139161	2	CARTRIDGE, COUNTER BALANCE VALVE	
..	HC-139171	2	BODY, COUNTER BALANCE VALVE	
NS	HC-140361	2	SEAL KIT, COUNTER BALANCE VALVE	
2	HC-140312	2	CYLINDER, MAIN LEVELING	
NS	HC-142451	2	SEAL KIT, MAIN LEVELING CYLINDER	
3	HC-140341	1	CYLINDER, MASTER	
NS	HC-134201	1	SEAL KIT, MASTER CYLINDER	
4	HC-138581	1	CYLINDER, SLAVE	
NS	HC-141281	1	SEAL KIT, SLAVE CYLINDER	
5	LM-261081	1	HM BLOCK, CODE 62 90°	MOUNTS TO BOTTOM PORT ON HYDRO MOTOR
6	HC-143361	1	CODE 62/CODE 62 ELBOW	MOUNTS TO TOP PORT ON HYDRO MOTOR
7	HC-143371	1	CODE 62 90° ROTATIONAL ADAPTER	MOUNTS TO BOTTOM PORT ON HYDRO MOTOR
8	HC-143101	1	HYDRAULIC PUMP, HILLMASTER, TRIPLE M	JD PART NUMBER AH212540
A	F-SSS-04F04	8	SCREW, SOCKET SET 1/4-28 X 1/4	ALL CYLINDERS
B	F-HC8-07C24	8	HC8 7/16-14 X 1-1/2	CODE 62 SPLT FLANGE
C	F-HC8-07C52	8	HC8 7/16-14 X 3-1/4	THESE FASTENERS COME WITH ELBOWS
C	F-LWH-07	8	LW 7/16 HD	THESE FASTENERS COME WITH ELBOWS
D	F-SHC-07C20	4	SHCS 7/16-14 X 1-1/4	THESE FASTENERS COME WITH ROTATIONAL ADAPTER
D	F-LWHC-07	4	LW 7/16 HD HIGH COLLAR	THESE FASTENERS COME WITH ROTATIONAL ADAPTER
CODE 62 SPLIT FLANGE CONNECTOR KIT ASSEMBLY				
ASM	HC-101843	2	ASM, CODE 62 SLT FLNG CONNECTOR KIT WITH O-RINGS	FWD AND REVERSE PROPULSION HOSE
ONE HC-101843 KIT INCLUDES:				
9	HC-134911	3	O-RING, CODE 62 CONNECTOR	
10	HC-137891	1	PLATE, CODE 62	
11	HC-137901	2	CODE 62, #16 SPLIT FLANGE KIT (PAIR)	
NS	F-HC8-07C44	4	HC8 7/16 X 2-3/4 PLT	
NS	F-HN8-07C	4	HN8 7/16-14	
RETURN FILTER ASSEMBLY & FASTENERS				
12	LP-261111	1	HM MOUNT, RETURN FILTER	
13	HC-143441	1	FILTER ASM, OIL	SUBS TO JD PART NUMBER AH125733
E	F-HCF-10M020E	4	FLHC-10.9 M10 X 1.50 X 20	FILTER HOUSING TO MOUNTING BRACKET
F	F-HCF-8M020E	2	FLHC-10.9 M8 X 1.25 X 20	RETURN FILTER BRACKET TO COMBINE
F	F-HNF-8ME	2	FLHN-10.9 M8 X 1.25	RETURN FILTER BRACKET TO COMBINE

Model 2970S Hillco Leveling System
For Serial Numbers 2970S-1035 thru 2970S-1075

HYDRAULIC MANIFOLD

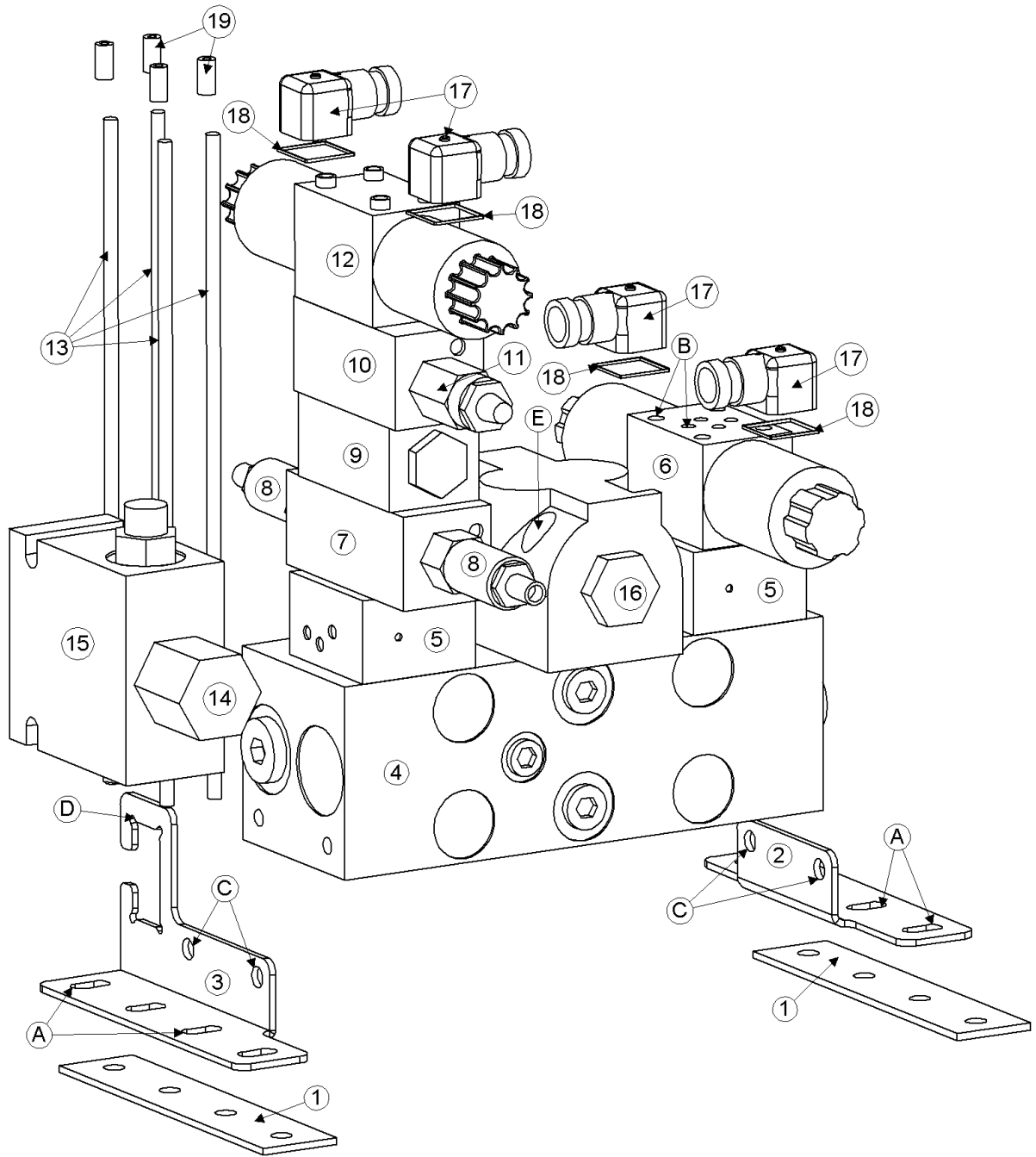

Model 2970S Hillco Leveling System
For Serial Numbers 2970S-1035 thru 2970S-1075

MANIFOLD COMPONENTS				
REF.	PART NO.	QTY.	PART NAME	NOTES
1	LM-260211	2	HM PLT, MANIFOLD MNT WASHER	
2	LP-250041	1	HM PLATE, MANIFOLD MNT	
3	LP-261031	1	HM MOUNT, MANIFOLD ELECTRICAL	
4	HC-142981	1	MANIFOLD, 3-STATION W/ RELIEF CAVITY	
5	HC-143001	2	ADAPTER, D03/D05 VALVE	LEVELING AND TRIM SECTIONS OF MAN
6	HC-140411	1	VALVE, DIRECTIONAL CONTROL, PROPORTIONAL	LEVELING PORTION OF MANIFOLD
NS	HC-142731	1	SEAL KIT, DIRECTIONAL CONTROL VALVE	FOR HC-140411
7	HC-143731	1	HOUSING, DUAL RELIEF	TRIM PORTION OF MANIFOLD
8	HC-142991	3	CARTRIDGE, PRESSURE RELIEF	MANIFOLD AND DUAL RELIEF HOUSING
NS	HC-145191	1-3	SEAL KIT, PRESSURE RELIEF CARTRIDGE	
9	HC-101034	1	CHECK VALVE, DUAL PILOT OPERATED	TRIM PORTION OF MANIFOLD
10	HC-143061	1	BODY, FLOW CONTROL	TRIM PORTION OF MANIFOLD
11	HC-143741	1	CARTRIDGE, PRESSURE COMP FLOW CONTROL	TRIM PORTION OF MANIFOLD
NS	HC-145211	1	SEAL KIT, PRESSURE FLOW CONTROL	
12	HC-143011	1	VALVE, DIRECTIONAL CONTROL, BANG/BANG	TRIM PORTION OF MANIFOLD
NS	HC-142731	1	SEAL KIT, DIRECTIONAL CONTROL VALVE	FOR HC-143011
13	LM-260871	4	HM STUD, MANIFOLD TRIM	TRIM PORTION OF MANIFOLD
14	HC-143081	1	VALVE, PRIORITY FLOW CONTROL	PRESSURE LINE FROM JD PUMP TO MANIFOLD
NS	HC-145201	1	SEAL KIT, PRIORITY FLOW CONTROL VALVE	
15	HC-143091	1	BODY, PRIORITY FLOW CONTROL VALVE	PRESSURE LINE FROM JD PUMP TO MAN
16	HC-143071	1	VALVE, D05 SOFT SHIFT DUMP	MIDDLE STATION ON MANIFOLD
NS	HC-145221	1	SEAL KIT, DUMP VALVE	
17	HC-140291	5	PLUG, DIN, LIGHTED	COILS ON DIR CONTROL VALVES
NS	HC-143981	1	O-RING R26448	JD PART NUMBER R26448
NS	HC-143991	1	HYDRAULIC QUICK-CONNECT COUPLER	JD PART NUMBER AH125760
NS	HC-144001	1	COVER, DUST R77175	JD PART NUMBER R77175
18	HC-142971	5	GASKET, DIN CONNECTOR	COILS ON DIR CONTROL VALVES
19	HC-139871	4	NUT STUD, 10-24	
NS	HC-143971	-	O-RING, DO3 SUBPLATE	QTY - AS NEEDED
NS	HC-145181	-	O-RING, DO5 SUBPLATE	QTY - AS NEEDED
MANIFOLD FASTENERS				
A	F-HCF-8M020F	4	FLHC-8.8 M8 X 1.25 X 20	MANIFOLD BRACKET
A	F-HNF-08MF	4	FLHN-8.8 M8 X 1.25	MANIFOLD BRACKET
B	F-SHC-#10C52	4	SHCS 10-24 X 3-1/4	LEVELING STATION OF MANIFOLD
B	F-LW-#10	4	LW #10	LEVELING STATION OF MANIFOLD
C	F-HCF-05C08	4	HC5 5/16-18 X 1/2 FLANGE	MANIFOLD TO BRACKET
D	F-PHM-#6C08	4	PHMS 6-32 X 1/2	RECEPTACLE PLUG MOUNTING
D	F-HNF-#6C	4	FLHN 6-32 SERR.	RECEPTACLE PLUG MOUNTING
E	F-SHC-04C28	4	SHCS 1/4-20 X 1-3/4	DUMP VALVE ON MANIFOLD

Model 2970S Hillco Leveling System
For Serial Numbers 2970S-1035 thru 2970S-1075

HYDRAULIC HOSES

LEVELING				
REF.	PART NO.	QTY.	PART NAME	WHERE USED
NS	LA-138981	2	3/8" 100R2 59" #6 FORS X #6 FORS	LEFT OR RIGHT POCV#2 TO RIGHT/LEFT ROD FRONT
NS	LA-252151	2	1/4" 100R2 17-1/2" #6 FORS X #6 FORS	LEFT OR RIGHT POCV#3 TO RIGHT/LEFT ROD REAR
NS	LA-139102	1	3/8" 100R2 111" #6 FORS X #6 FORS	LEVELING VALVE PORT "A" TO LEFT MAIN LEV ROD
NS	LA-143491	1	3/8" 100R2 111" #6 FORS X #6 FORS 90°	LEVELING VALVE PORT "B" TO LEFT MAIN LEV CYL POCV #2
HYDROSTAT				
NS	LA-140383	2	1 100R15 79" CODE 62 SPLT FLNG 90° SHORT DROP X CODE 62 SPLT FLNG STR	HYDROSTAT
NS	LA-140401	1	3/4 100R1 HOSE 38-1/2" #12 MORS X #12 FORS 45°	HYDRO MOTOR CASE DRAIN
NS	HC-101843	2	CODE 62 SLT FLNG CONNECTOR KIT WITH O-RINGS	**SEE HYDRAULIC PAGE 6-2
GREASE				
NS	LA-138942	1	3/16 R1 GREASE HOSE 22-3/4" 1/8 MPT X 1/8 MPT	MASTER BASE TO BH #4
NS	LA-138951	1	3/16 R1 GREASE HOSE 40" 1/8 MPT X 1/8 MPT	RH MAIN LEN CYL BASE TO BH #1
NS	LA-138962	1	3/16 R1 GREASE HOSE 61" 1/8 MPT X 1/8 MPT	MAIN PVT TO BH #3
NS	LA-138971	1	3/16 R1 GREASE HOSE 94-1/2" 1/8 MPT X 1/8 MPT	LH MAIN LEV CYL BASE TO BH #2
BRAKES				
NS	LA-130371	2	#4 TITE FLEX W / #4 FORS X #4 MORS 31"	
NS	HA-133131	2	TEFLON O-RING	
PUMP AND MANIFOLD HOSES				
NS	LA-143501	1	3/4" 100R2 HOSE 138" #12 FORS X #12 FORS 45°	PRESSURE HOSE FROM PUMP TO PRIORITY VALVE #1
NS	LA-143691	1	3/4" 100R1 HOSE 160" #12 FORS X #12 FORS 45°	MANIFOLD "T" PORT TO FILTER HOUSING INLET
NS	LA-143531	1	3/4" 100R1 HOSE 36" #12 FORS X #12 FORS 90°	FILTER HOUSING OUTLET TO RESERVOIR
NS	LA-143681	1	1" 100R16 (1M2T) HOSE 42" #16 FORS X #16 FORS	SUCTION HOSE FROM RUN END OF BTM TEE TO PUMP
FOR COMBINES WHICH FALL BETWEEN THE FOLLOWING SERIAL NUMBER BREAKS: 9660 STS (715401-); 9761 STS (715501-); 9860 STS (715601-)				
NS	LA-143511	1	1/2" 100R2 HOSE 43" #8 FORS X #10 FORS 90°	PRIORITY VALVE #3 TO HIC MANIFOLD
FOR COMBINES WHICH FALL BETWEEN THE FOLLOWING SERIAL NUMBER BREAKS: 9650 STS (ALL); 9750 STS (ALL); 5660 STS (-715400); 9760 STS (-715500); 9860 STS (-715600)				
NS	LA-143831	1	1/2" 100R2 HOSE 25" #8 FORS X #10 FORS 90°	PRIORITY VALVE #3 TO Z STACK VALVE
HEADER LIFT CYLINDER HOSES				
NS	LA-143791	1	1/2" 100R2 HOSE 49" #8 FORS X #8 FORS	HEADER LIFT CYLINDERS
NS	HC-143841	1	ABRASION SLEEVE, NYLON 1.06" ID X 48"	HOSE BETWEEN HEADER LIFT CYLINDERS
TRIM HOSES				
NS	LA-139112	1	1/4" 100R2 60" #4 FORS X #4 FORS	TRIM PORT "A" TO TEE CONNECTED TO HOSE LA-143481
NS	LA-139112	1	1/4" 100R2 60" #4 FORS X #4 FORS	TRIM PORT "B" TO TEE CONNECTED TO HOSE LA-143471
NS	LA-139122	1	1/4" 100R2 233" #4 FORS X #4 FORS	SLAVE ROD TO TEE CONNECTED TO HOSE LA-143481
NS	LA-139132	1	1/4" 100R2 245" #4 FORS X #4 FORS	SLAVE BASE TO TEE CONNECTED TO HOSE LA-143471
NS	LA-139531	1	1/4" 100R2 295" #4 FORS X #6 FORS	SLAVE CYLINDER ROD TO RELIEF VALVE #2
NS	LA-139541	1	1/4" 100R2 309" #4 FORS X #6 FORS	SLAVE CYLINDER BASE TO RELIEF VALVE #1
NS	LA-143471	1	1/4" 100R2 106" #4 FORS X #4 FORS	MASTER BASE TO TEE THAT CONNECTS TO HOSE LA-139132
NS	LA-143481	1	1/4" 100R2 117" #4 FORS X #4 FORS	MASTER ROD TO TEE THAT CONNECTS TO HOSE LA-139122
NS	HC-143581	1	ABRASION SLEEVE, NYLON 1.22" ID X 24"	SLAVE CYLINDER HOSES THRU FEEDER PIVOT AREA
NS	HC-143701	1	ABRASION SLEEVE, NYLON 1.22" ID X 36"	ON TRIM HOSES NEAR SLAVE CYLINDER

Model 2970S Hillco Leveling System
For Serial Numbers 2970S-1035 thru 2970S-1075

HYDRAULIC ADAPTERS

MAIN CYLINDERS				
REF.	PART NO.	QTY.	PART NAME	WHERE USED
NS	HA-L-6MF6MO	4	#6 MORS X #6 MORB 90°	POCV #2,#3 LEFT & RIGHT
NS	HA-K-6MF6MO	2	#6 MORB X #6 MORS BRANCH TEE	LEFT AND RIGHT LEV CYL ROD
NS	HA-L-6MO6MO	2	#6 MORB X #6 MORB 90°	POCV #1 LEFT AND RIGHT LEV CYL BASE
NS	HA-M-6FF6MF	2	#6 FORS X #6 MORS SWIVEL NUT RUN TEE	LEFT MAIN LEV CYL ROD/ LEFT POCV #2
NS	HA-L-6FF6MF	3	#6 FORS X #6 MORS 90°	LEFT AND RIGHT LEV CYL ROD
NS	HA-L-6FF6MF	1	#6 MORS X #6 FORS 90°	RIGHT LOWER POCV #2
MASTER AND SLAVE CYLINDERS				
NS	HA-L-4MF6MO	2	#4 MORS X #6 MORB 90°	MASTER CYLINDER ROD AND BASE
NS	HA-L-4MF6MO	2	#4 MORS X #6 MORB 90°	SLAVE CYLINDER ROD AND BASE
NS	HA-Y-4MF4MF	2	#4 MORS UNION TEE	WHERE SLAVE AND MASTER LINES JOIN
HEADER LIFT CYLINDER				
NS	HA-Q-8FF8MF	1	#8 ORS STRAIGHT THREAD BRANCH TEE	LEFT HEADER LIFT CYLINDER
NS	HA-L-8MF8MO	1	#8 MORB X #8 MORS 90°	RIGHT HEADER LIFT CYLINDER
GREASE FITTINGS				
NS	HA-S-2FP2MN	4	1/8" NPSM X 1/8" FPT BULKHEAD CONNECTOR	GREASE BULKHEAD MOUNT
NS	HA-NJ-2FN	4	1/8" NPSM BULKHEAD LOCKNUT	BULKHEAD CONNECTOR
NS	HC-138011	4	1/4-28 STRAIGHT ZERK	ALL GREASE LINES
NS	HA-L-2FP2MP	1	1/8 NPT 90 STREET EL	MAIN PIVOT PIN
NS	HC-135771	3	1/4-28 MALE X 1/8 FPT 90°	MASTER CYLINDER BASE, MAIN LEV CYL BASE
RESERVOIR				
NS	HA-L-16MF16MO	1	#16 MORB X #16 MORS 90°	SUCTION PORT ON RESERVOIR (POINTED DOWN)
NS	HA-M-16FF16MF	2	#16 ORS SWIVEL NUT RUN TEE	CONNECTED TO 90° ADAPTER ON SUCTION PORT
NS	HA-S-12MF16FF	1	#12 MORS X #16 FORS STR	ON TEE SIDE OF BTM RUN TEE FOR RETURN
PUMP				
NS	HA-L-10MO12MF	1	#10 MORB X #12 MORS 90°	PUMP PRESSURE PORT TO PRIORITY VALVE
NS	HA-L-16MF16MO	1	#16 MORB X #16 MORS 90°	MIDDLE PUMP SUCTION PORT
RETURN FILTER HOUSING				
NS	HA-L-12MF16MO	2	#16 MORB X #12 MORS 90°	INLET & OUTLET PORTS ON FILTER HOUSING
MANIFOLD				
NS	HA-A-12MO	2	#12 MORB ALLEN HEAD PLUG	"P" & "T" PORTS
NS	HA-L-12MO12MO	1	#12 MORB X #12 MORB 90°	"P" PORT & #2 PORT ON PRIORITY VALVE
NS	HA-L-12MF12MO	1	#12 MORB X #12 MORS 90°	"T" PORT
NS	HA-L-6MF8MO	2	#8 MORB X #6 MORS 90	"A" & "B" LEVELING PORTS
NS	HA-S-4MF8MO	2	#8 MORB X #4 MORS STR	TRIM A & B PORTS
NS	HA-L-4FF4MF	2	#4 FORS X #4 MORS 90	TRIM A & B PORTS
NS	HA-A-8MO	2	#8 MORB ALLEN HEAD PLUG	CENTER STATION "A" & "B" PORTS
NS	HA-L-12MF12MO	1	#12 MORB X #12 MORS 90°	#1 PORT ON PRIORITY VALVE
NS	HA-S-8MF12MO	1	#12 MORB X #8 MORS STR	#3 PORT ON PRIORITY VALVE
OPTIONAL				
NS	HA-E-6MF	1	#6 MORS PLUG	
NS	HA-E-4MF	1	#4 MORS PLUG	

Model 2970S Hillco Leveling System
For Serial Numbers 2970S-1035 thru 2970S-1075

7 MISCELLANEOUS

DECALS AND LITERATURE				
REF.	PART NO.	QTY.	PART NAME	DESCRIPTION
NS	LL20-100782	1	CAUTION LEVELING SYSTEM CAB	WINDOW IN CAB
NS	LL20-100783	2	DANGER - CRUSHING HAZARD	ON SIDES OF DA ASM
NS	LL20-100784	2	DECAL, DANGER PINCH POINT	RH & LH UPPER TRANS FACE PLT
NS	LL20-100786	1	WARNING ELECTRONIC CRUSHING HAZARD	FRONT OF CONTROL BOX
NS	LL20-100787	1	CAUTION - LEVELING SYSTEM HAZARD	ON LADDER PLATFORM
NS	LL20-100788	1	DANGER - HYDRAULIC HAZARD	ON SIDE OF COMBINE ABOVE THE HYDRAULIC MANIFOLD
NS	LL20-100788	0	DANGER - HYDRAULIC HAZARD	1 - EACH MAIN CYLINDER
NS	LL-133741	1	LABEL, GREASE 50 HRS	OC BULKHEAD
NS	LL-133741	2	LABEL, GREASE 50 HRS	MAIN LEV CYL BOTTOM (RH & LH)
NS	LL-133741	1	LABEL, GREASE 50 HRS	MASTER CYLINDER ROD
NS	LL-141301	2	DECAL, SIDEHILL LEVELING SYSTEM	SIDE OF COMBINE
NS	LL-143621	2	DANGER, AVOID CRUSHING INJURY	IN AREA NEAR SAFETY STOP STORAGE LOCATION
NS	LA-255961	1	TAG, SERIAL NUMBER	
NS	D-060714ADL01A	1	MANUAL, PARTS	
NS	D-060609SGD01	1	MANUAL, OPERATORS	
HOSE CLAMPS AND FASTENERS				
NS	MC-137521	3	TANDEM CLAMPING HALVES BEHRINGER (PAIR)	HYDROSTAT HOSES
NS	MC-137531	3	COVER PLATE W/ 5/16 HOLE (BEHRINGER)	HYDROSTAT HOSES
NS	F-HCF-08M090F	2	FLHC-8.8 M8 X 1.25 X 90	BEHRINGER CLAMP FOR HYDRO HOSES
NS	F-HNF-08ME	2	FLHN-10.9 M8 X 1.25	BEHRINGER CLAMP FOR HYDRO HOSES
NS	F-HC-08M100F	2	HC-8.8 M8 X 1.25 X 100	BEHRINGER CLAMP FOR HYDRO HOSES
NS	F-HC-08M120F	1	HC-8.8 M8 X 1.25 X 120	BEHRINGER CLAMP FOR HYDRO HOSES
NS	MC-135631	2	CLAMP, HOSE 1-1/2 R/C W 3/8 HOLE	CLAMP, GREASE LINES/ TRIM HOSES
NS	HC-142061	1	SLEEVE, ABRASION,SHIFT CABLE 36"	SLEEVE, ABRASION, SHIFT CABLE
NS	HC-139221	2	CLAMP, 1/4" TUBE TANDEM (PAIR)	BRAKE LINES
NS	HC-139231	4	CLAMP, COVER PLATE FOR 1/4" TUBE CLAMP	BRAKE LINES
NS	F-HNF-08ME	1	FLHN- 10.9 M8 X 1.25 PLT	BRAKELINE TANDEM CLAMP
NS	F-HCF-8M050E	1	FLHC- 10.9 M8 X 1.25 X 50 PLT	BRAKELINE TANDEM CLAMP
NS	HC-133541	1	ABRASION SLEEVE, NYLON -- 2.19 ID X 32 IN	LEVELING AND TRIM HOSES FROM OC
NS	HC-143601	3	CLAMP, HOSE 1-1/8" R/C W/ 3/8 HOLE	GREASE HOSES & MASTER CYLINDER HOSES
NS	MC-135631	1	CLAMP, HOSE 1-1/2 R/C W 3/8 HOLE	CLAMP TRIM HOSES UNDER FEEDER HOUSE
NS	HC-143601	1	CLAMP, HOSE 1-1/8" R/C W/ 3/8 HOLE	CLAMP TRIM HOSES UNDER FEEDER HOUSE
NS	HC-143601	2	CLAMP, HOSE 1-1/8" R/C W/ 3/8 HOLE	CASE DRAIN HOSE
NS	MC-101343	2	CLAMP, HOSE 2-7/16" R/C W/ 3/8 HOLE	PRESSURE AND RETURN HOSES ABOVE HYDRO HOSES
NS	F-HCF-8M020E	2	FLHC-10.9 M8 X 1.25 X 20	HOSE CLAMPS FROM MANIFOLD TO OC
NS	F-HNF-8ME	2	FLHN-10.9 M8 X 1.25	HOSE CLAMPS FROM MANIFOLD TO OC
NS	MC-135791	4	CLAMP, HOSE 7/8" R/C W/ 3/8 HOLE	SHIFTING CABLE & HDR LIFT CYL HOSE

8 PART NUMBER INDEX

PART NUMBER	PAGE NUMBER	PART NUMBER	PAGE NUMBER	PART NUMBER	PAGE NUMBER
D-060609SGD01	7-1	F-HC8-07C52	6-2	HA-E-4MF	6-6
D-060714ADL01A	7-1	F-HC8-12C240	3-4	HA-E-6MF	6-6
EC-100164	5-2	F-HC-8M020E	2-4	HA-K-6MF6MO	6-6
EC-100165	5-2	F-HCF-05C08	6-4	HA-L-10MO12MF	6-6
EC-100557	5-2	F-HCF-08M090F	7-1	HA-L-12MF12MO	6-6
EC-100692	5-2	F-HCF-10M020E	6-2	HA-L-12MF16MO	6-6
EC-133281	5-2	F-HCF-10M035E	2-4, 3-4	HA-L-12MO12MO	6-6
EC-136631	5-2	F-HCF-10M040F	3-4	HA-L-16MF16MO	6-6
EC-136701	5-2	F-HCF-12M040E	2-4	HA-L-2FP2MP	6-6
EC-136711	5-2	F-HCF-12M040F	3-4	HA-L-4FF4MF	6-6
EC-138781	5-2	F-HCF-16M040E	2-4	HA-L-4MF6MO	6-6
EC-139631	5-2	F-HCF-8M020E	2-4, 3-4, 6-2, 7-1	HA-L-6FF6MF	6-6
EC-139641	5-2	F-HCF-8M020F	6-4	HA-L-6MF6MO	6-6
EC-140781	5-2	F-HCF-8M050E	7-1	HA-L-6MF8MO	6-6
EC-140801	5-2	F-HN8-07C	6-2	HA-L-6MO6MO	6-6
EC-140841	5-2	F-HNF-#10C	5-2	HA-L-8MF8MO	6-6
EC-140851	5-2	F-HNF-#6C	6-4	HA-M-16FF16MF	6-6
EC-140861	5-2	F-HNF-04C	5-2	HA-M-6FF6MF	6-6
EC-141741	5-2	F-HNF-08ME	2-4, 3-4, 7-1	HA-NJ-2FN	6-6
EC-141751	5-2	F-HNF-08MF	6-4	HA-Q-8FF8MF	6-6
EC-141761	5-2	F-HNF-10MF	3-4	HA-S-12MF16FF	6-6
EC-141771	5-2	F-HNF-16ME	2-4, 3-4	HA-S-2FP2MN	6-6
EC-141781	5-2	F-HNF-8ME	3-4, 6-2, 7-1	HA-S-4MF8MO	6-6
EC-141791	5-2	F-HNN-10MF	2-4	HA-S-8MF12MO	6-6
EC-141801	5-2	F-HNN-8MF	3-2	HA-Y-4MF4MF	6-6
EC-141831	5-2	F-HNS-10ME	2-4, 3-4	HC-101034	6-4
EC-142121	5-2	F-HNS-12C	3-4	HC-101843	6-2, 6-5
EC-143271	5-2	F-HNS-12ME	3-4	HC-133541	7-1
EC-143281	5-2	F-HNS-16ME	2-4, 4-2	HC-134201	6-2
EC-143301	5-2	F-HNS-8ME	2-4	HC-134911	6-2
EC-143311	5-2	F-LW-#10	6-4	HC-135771	6-6
EC-143321	5-2	F-LW-04	5-2	HC-137891	6-2
EC-143421	5-2	F-LWE-04	5-2	HC-137901	6-2
EC-143811	5-2	F-LWH-07	6-2	HC-138011	6-6
ET-ST-20#10	5-2	F-LWHC-07	6-2	HC-138581	2-2, 6-2
ET-ST-2004	5-2	F-MB-14NR40	2-4	HC-138901	3-2, 6-2
F-CB-10M050F	2-4	F-PCT-02X16	2-4	HC-139161	6-2
F-CB-16M050E	2-4	F-PHM-#10C16	5-2	HC-139171	6-2
F-FHS-8M030E	2-4	F-PHM-#10C28	5-2	HC-139221	7-1
F-FWF-06020	3-4	F-PHM-#6C06	5-2	HC-139231	7-1
F-FWH-10	3-4, 4-2	F-PHM-#6C08	6-4	HC-139871	6-4
F-HC-08M100F	7-1	F-PHM-04C24	5-2	HC-140291	6-4
F-HC-08M120F	7-1	F-PHM-04C36	5-2	HC-140312	3-2, 6-2
F-HC-10M070E	2-4	F-SHC-#10C52	6-4	HC-140341	3-2, 6-2
F-HC-16M050E	2-4	F-SHC-04C28	6-4	HC-140361	6-2
F-HC-16M060E	4-2	F-SHC-07C20	6-2	HC-140411	6-4
F-HC-16M110E	3-4	F-SHC-24M080E	3-4	HC-141281	6-2
F-HC-16M120E	2-4, 3-4	F-SSS-04F04	6-2	HC-142061	7-1
F-HC-16M250E	4-2	F-UDS-#7X06	3-4	HC-142451	6-2
F-HC5-04C12	5-2	HA-133131	6-5	HC-142731	6-4
F-HC8-07C24	6-2	HA-A-12MO	6-6	HC-142971	6-4
F-HC8-07C44	6-2	HA-A-8MO	6-6	HC-142981	6-4

Model 2970S Hillco Leveling System
For Serial Numbers 2970S-1035 thru 2970S-1075
PART NUMBER INDEX (CONTINUED)

PART NUMBER	PAGE NUMBER	PART NUMBER	PAGE NUMBER	PART NUMBER	PAGE NUMBER
HC-142991	6-4	LA-235711	3-2	LM-248781	3-2
HC-143001	6-4	LA-246702	4-2	LM-250533	2-2
HC-143011	6-4	LA-247093	3-2	LM-250541	2-2
HC-143061	6-4	LA-247284	3-2	LM-250561	2-2
HC-143071	6-4	LA-247482	3-2	LM-250571	2-2
HC-143081	6-4	LA-250163	2-2	LM-250581	2-2
HC-143091	6-4	LA-250243	2-2	LM-255331	5-2
HC-143101	6-2	LA-250713	2-2	LM-255341	5-2
HC-143361	6-2	LA-252151	6-5	LM-260211	6-4
HC-143371	6-2	LA-252462	5-4	LM-260591	3-2
HC-143441	6-2	LA-252472	5-4	LM-260821	2-2
HC-143581	6-5	LA-252482	5-4	LM-260871	6-4
HC-143601	7-1	LA-253131	3-2	LM-261081	6-2
HC-143701	6-5	LA-253882	2-2, 3-2	LM-261091	3-2
HC-143731	6-4	LA-255621	5-2, 5-4	LP-230241	3-2
HC-143741	6-4	LA-255631	5-4	LP-235092	4-2
HC-143841	6-5	LA-255642	5-4	LP-247961	3-2
HC-143971	6-4	LA-255721	5-4	LP-250041	6-4
HC-143981	6-4	LA-255731	5-4	LP-250522	2-2
HC-143991	6-4	LA-255821	5-2, 5-4	LP-250551	2-2
HC-144001	6-4	LA-255961	3-2, 7-1	LP-252241	3-2
HC-145181	6-4	LA-260221	5-4	LP-258221	3-2
HC-145191	6-4	LA-260231	5-4	LP-260791	2-2
HC-145201	6-4	LA-260241	5-4	LP-260801	2-2
HC-145211	6-4	LA-260251	5-4	LP-260811	2-2
HC-145221	6-4	LA-260361	5-4	LP-261031	6-4
LA-130371	6-5	LA-260721	2-2	LP-261111	6-2
LA-138942	6-5	LA-260771	2-2	LP-261121	3-2
LA-138951	6-5	LA-260851	2-2	LP-261351	2-2
LA-138962	6-5	LA-260861	2-2	LP-261431	3-2, 5-2
LA-138971	6-5	LA-261021	2-2	LP-261531	3-2
LA-138981	6-5	LA-261141	5-4	LTP-241721	2-2
LA-139102	6-5	LA-261151	5-4	MC-101343	7-1
LA-139112	6-5	LA-261161	5-4	MC-135531	2-2
LA-139122	6-5	LA-261171	5-4	MC-135631	7-1
LA-139132	6-5	LA-261371	3-2	MC-135791	7-1
LA-139531	6-5	LA-261481	5-4	MC-137521	7-1
LA-139541	6-5	LA-261661	5-4	MC-137531	7-1
LA-140383	6-5	LA-261691	5-4	MC-138641	3-2
LA-140401	6-5	LA-262021	3-2	MC-138651	3-2
LA-143471	6-5	LL-133741	7-1	MC-141331	2-2
LA-143481	6-5	LL-141301	7-1	MC-141551	3-2
LA-143491	6-5	LL-143621	7-1	MC-142261	2-2
LA-143501	6-5	LL20-100782	7-1	MC-142921	3-2
LA-143511	6-5	LL20-100783	7-1	MC-143461	2-2
LA-143531	6-5	LL20-100784	7-1	MC-143591	2-2
LA-143681	6-5	LL20-100786	7-1	MC-143631	2-2
LA-143691	6-5	LL20-100787	7-1	MC-143641	2-4
LA-143791	6-5	LL20-100788	7-1	MC-143711	3-4
LA-143831	6-5	LM-226841	2-2	MC-143721	3-4
LA-230552	3-2	LM-229192	2-2		