

**LT-100**  
**LATERAL HEADER TILT**  
**SYSTEM**  
***INSTALL MANUAL***  
***50 SERIES***  
*D-030602CLA02*





# LT-100

LATERAL TILT SYSTEM FOR JOHN DEERE COMBINES

## INSTALLATION INSTRUCTIONS

For John Deere 9450, 9550, 9650, 9650 CTS II, 9650 STS & 9750 STS Combines

**NOTE:** The terms “Left, Right, Top, Bottom, Front or Back” used in this manual are referenced as if sitting in the operator’s seat of the combine facing the direction of travel.

1. Remove the feederhouse shields (A) and the cast header mount blocks. (B)

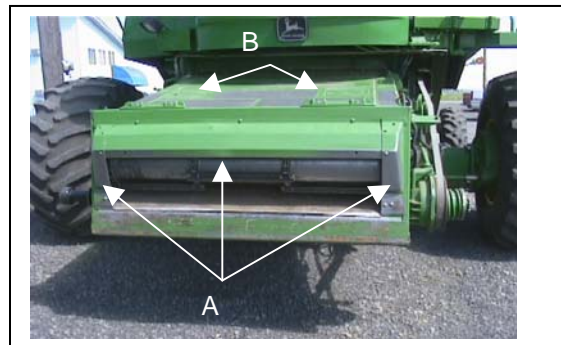

2. Roll the feeder chain until the master links (A) are at the front of the feeder chain drum. Remove the master links and set aside.

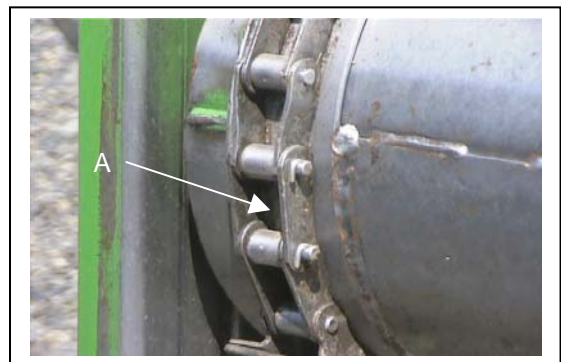

**Caution: The feeder drum is awkward to handle. Use safe lifting practices and/or appropriate lifting devices.**

3. Block the feeder drum to prevent it rolling out. Remove the feeder chain drum bolts. Remove the drum from the feederhouse.



4. Remove the JD feeder chain drum arms (A). Check feeder drum bearings and replace if needed. Install the Hillco arms with the blocks to the inside and hump to the top. Reinstall drum into the feeder house.

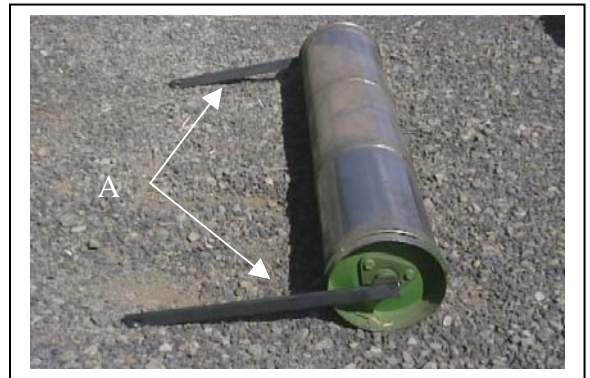

5. Install the Hillco feeder chain extensions from Bag #6. The 9650 use four extensions while the other models use three extensions. Add additional slats to maintain the slat timing. Fasten the slats use with M8x16 and M8 lock nuts from Bag #4. Tightened the feeder chain according to the John Deere procedure.

Note: Hillco does not supply the additional slats. Contact your JD dealer for these slats.

## LT-100 Installation Instructions

D-041607SGD01 REV1

6. Configure the shields to fit your combine.

The 9400, 9410, 9500, 9510, CTS, and CTS II models require the narrow position for the shields. Fasten the left and right throat fillers (E) with M8x30 carriage bolts to inside of LT-100 throat. Fasten the shield extensions (A) using the shield extensions. Fasten the left and right shields (B) with M8x30 flanged head bolts (C) on the top and M8x30 carriage head bolts (D) with the shield extension support brackets. Fasten the top shield (F) with the M8x30 flanged head bolts. These fasteners are found in Bag #8.

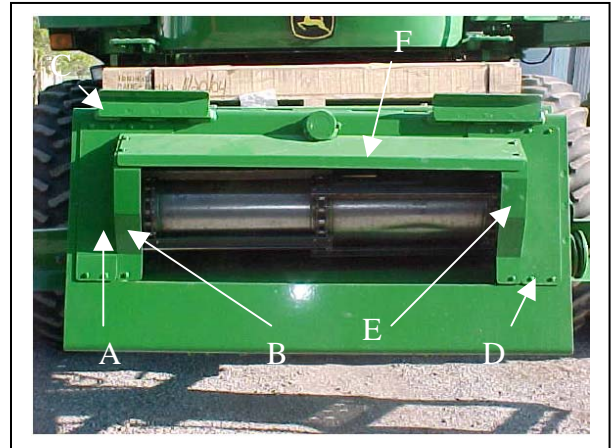

The 9650 Walker model require the wide position for the shields and do not require the throat fillers (E), shield extensions (A) or the shield extension brackets.



7. Using an appropriate lifting device, lift the LT-100 onto the front of the feederhouse and fasten with four M12x40 flanged head bolts (A). Later combines use four M16x40 flanged head bolts instead of the four M12x40 flanged head bolts. Engage the header lockout pins. Due to wear of the face plate, there can be variations in the fit of frame. It is generally better to leave the bolts loose until the lockout pins are engaged. Then tighten the mounting bolts to a torque of 105 lb-ft (140N-m) for the M12x40 bolts and 255 lb-ft (350N-m) for the M16x40 bolts.

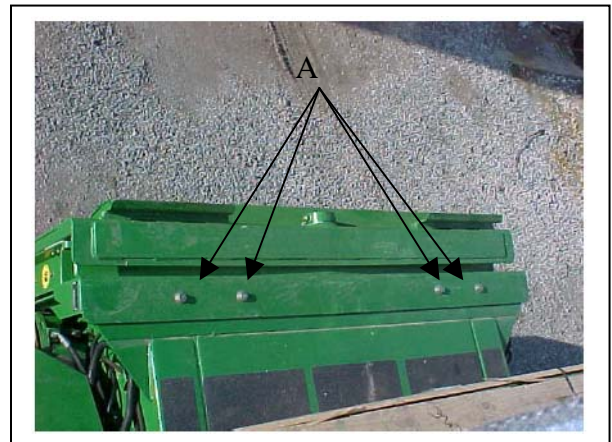

8. It is necessary to check the feeder drum clearance. Pry the feeder drum up until arms hit upper stops. With the drum in this position the slats should not be able to strike any of the structure of either the LT-100 or the feederhouse.

9. Relieve all pressure in the JD hydraulic stack valve by lowering the feederhouse to the ground. Once on the ground hold the feederhouse down switch a few seconds longer. Shut off the combine. Drain the hydraulic oil.

**Caution: HIGH PRESSURE FLUIDS**

**Escaping fluids under pressure can penetrate the skin causing serious injury.**

**Search for leaks with a piece of cardboard.**

**Relieve pressure before disconnecting hydraulic lines.**

**If an accident occurs consult a physician immediately.**

**Fluid injection into the skin must be surgically removed within a few hours or gangrene may result.**

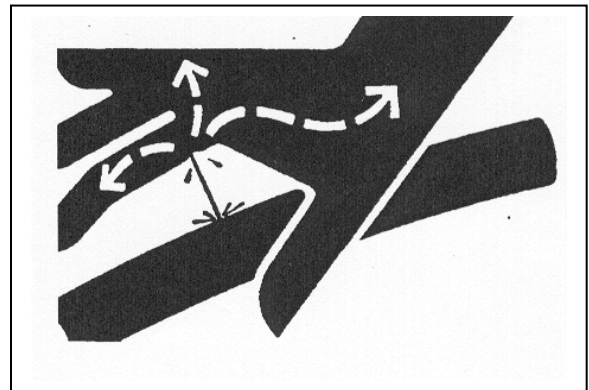

10. The Hillco supplied stack valve is configured for 9000 & 10 series JD combines and must be reconfigured for 50 series combines. Remove mounting plate with 4-cavity Amp connector. Use the Amp terminal extraction tool from Bag #5 to remove the wires. When done, the valve should appear like the valve on the right.

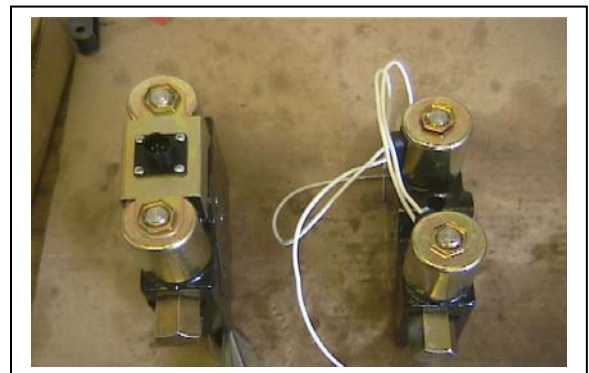

LT-100 Installation Instructions  
D-041607SGD01 REV1

11. Remove the nuts from the three tie bolts (A). Replace the tie bolts with longer tie bolts from Bag #1A, one bolt at a time.

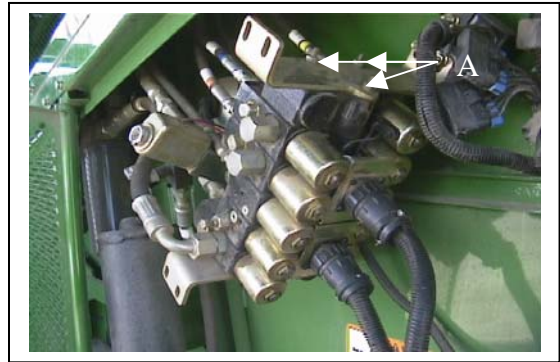

12. Remove the top stack valve bracket (A). Remove the cylinder speed valve (B). Replace the connector tubes with the tubes from Bag #1A. 50 series combines do not require the longer tubes found in Bag #1A. Install the Hillco valve (C) into the stack. Face the ball plugs in the same direction as the other valves in the stack. Reassemble the cylinder speed valve and bracket. Tighten nuts onto the tie bolts to a torque of 141LB-in (16N-m).

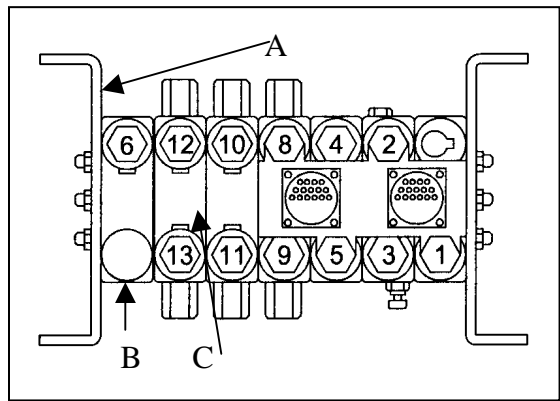

13. Plug one electrical lead from the #13 coil into the #13 hole of JD connector X240 (A), and plug the other lead from the #13 coil into #13 hole of JD connector X241 (B). Plug one lead from the #12 coil into the #12 hole of JD connector X240 (A), and plug the other lead from #12 coil into the #12 hole of the JD connector X241.

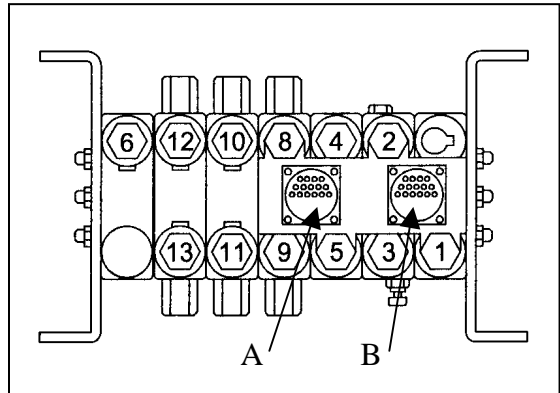

LT-100 Installation Instructions  
D-041607SGD01 REV1

14. For 9650STS and 9750STS route hoses LTA-242262 as shown. Connect the rod end of the cylinder to right port of the Hillco valve. Connect the base end to the left port of the Hillco valve. Use the clamps from Bag #4 (A) and zip ties to secure the hoses. Ensure the hoses are free of pinch and abrasion points.

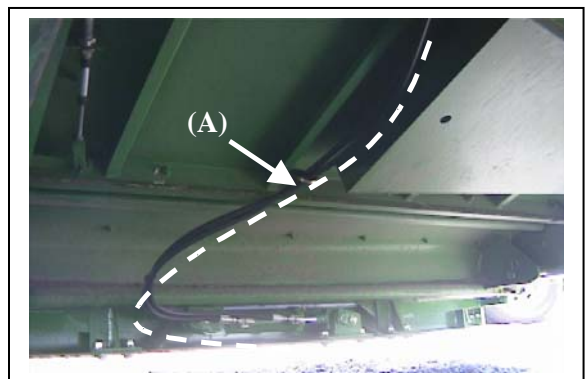
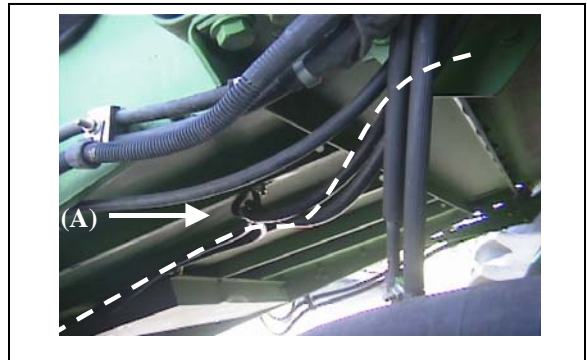

LT-100 Installation Instructions  
D-041607SGD01 REV1

15. For 50 series walker combines, route hoses LTA-242262 as shown. Connect the rod end of the cylinder to bottom port of the Hillco valve. Connect the base end to the top port of the Hillco valve. Use the clamps from Bag #4 (A) and zip ties to secure the hoses. Ensure the hoses are free of pinch and abrasion points.

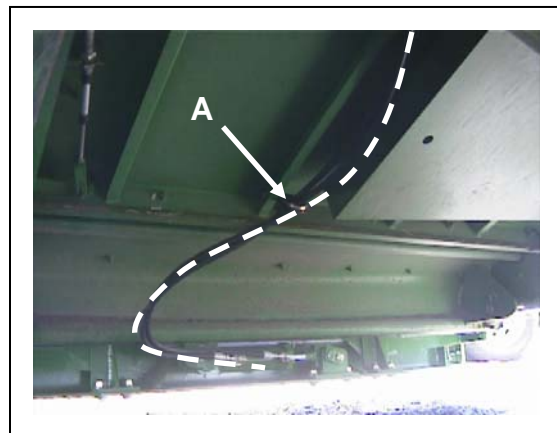
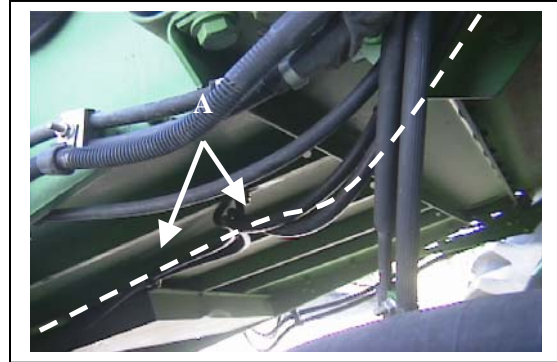

**Note: The JD hydro-handle (AH201287 or AH173094) must be purchased from a JD dealer.**



16. Remove the three screws from the bottom side of the console. Remove the nut and disconnect the hydro handle linkage. Remove the front screw from the armrest door hinge. Disconnect the three console connectors and remove the console. Unplug the hydro handle connector from the circuit board. Unbolt the clamp that holds the harness. Remove the two bolts and spring from the hydro handle. Remove the hydro handle and replace it with the new hydro handle. Assemble in reverse order.

17. On early 50 series combines (model year 2002 and below) it is necessary to confirm that the proper circuit board is installed in the Central Electronics Module located next to the left side of the cab. Typically on STS combines the board is installed in the top slot. On all other 50 series combines, it is typically found in the rightmost slot. The correct Contour Master circuit board is AH172613 or AH206189. The correct board is not installed it must be purchased from your JD dealer.

18. In the corner cab display, the address for Contour Master will need to be changed. The following information is from JD Technical Manual TM1902.

Locator	Control Unit	Address	Line2	Line3	Decription	Details
Contour Master	Cornerpost C03	121	----	1xxx	Display/Modify: Contour Master	1= Installed 0= Not installed

# LT-100 Installation Instructions

D-041607SGD01 REV1

**a. Prepare the combine for Calibration:**

- Turn the key switch to the RUN position

**b. Select Diagnostic Mode:**

- Press the Diagnostic Button on the Cornerpost Display 2 (CPD2).
- The Cornerpost Display 1 (CPD1) will display:

Line 1	---
Line 2	_dIA
Line 3	----

**c. Go to the desired controller:**

- Press the UP arrow or DOWN arrow button on the display to access the controller number CO3
- The CPD1 should display:

Line 1	----
Line 2	_CO3
Line 3	----

**d. Go to desired address:**

- Press the UP arrow or DOWN arrow button on the display to located the desired address (121).
- Line 1 will show the address alternating with "InP". This indicates that this address is one where numbers can be input.
- The CPD1 should display:

Line 1	_ 1 2 1
Line 2	----
Line 3	_ n n n

**e. Input the desired value:**

- Press the Enter button.
- The first number of the value shown in the Line 3 will flash.
- Press the UP or DOWN button to increase or decrease the value of the flashing digit.
- When the desired value ("1") is flashing, press the ENTER button to enter the new value into memory.

**f. Return to normal operation:**

- Press the BACK arrow on the CPD2 twice to return to normal operation.
- Turn the Key Switch OFF.
- The next time the machine is started, the combine will use this calibration information.

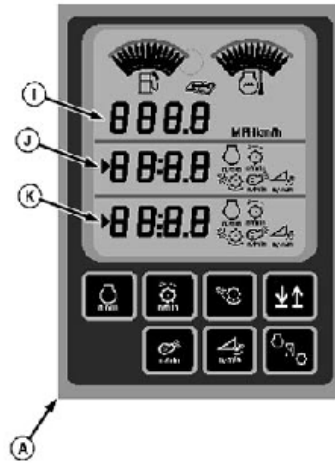
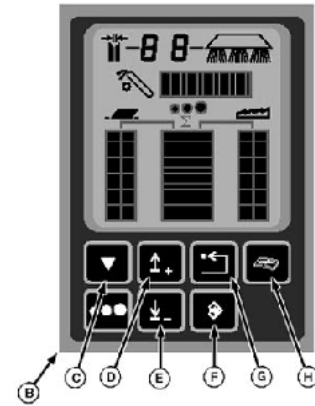

- A—Cornerpost Display 1
- B—Cornerpost Display 2
- C—Calibration Button
- D—Up Arrow Button
- E—Down Arrow Button
- F—Enter Button
- G—Back Arrow Button
- H—Diagnostic Button
- I—Line 1
- J—Line 2
- K—Line 3

**Do not try to calibrate the CONTOUR MASTER angle sensor unless the sensor has been installed.**

**Calibrating the angle sensor without sensor will cause an error code. The angle sensor is not necessary for the operation of the LT-100. If a working angle display is desired then the needed parts can be found in Appendix A.**

19. Before start-up, fill hydraulic oil system. Start the engine. Press the header tilt switch on the hydro-handle. It may take a little time till it starts to rotate. Rotate the header adapter several times to bleed the air out of the system. Check the hydraulic oil level and fill as necessary.

20. Start the combine and at low idle engage the separator. Rotate the header adapter through its range of motion and listen for sounds of the feeder chain striking either the LT-100 or the feederhouse. If no unusual sounds are heard, increase engine speed to full idle and again check for unusual sounds. If the feeder chain is striking, check to make that the feeder drum arms are correctly installed. Contact Hillco if the problem persists.

**THIS COMPLETES THE INSTALLATION.**

## 21. TROUBLE SHOOTING

**Problem:** The header adapter rotates in the opposite way as the switch is depressed.

**Solution:** The hoses are installed backwards. Switch the hoses at the cylinder.

**Problem:** The header adapter rotates one way but not the opposite way.

**Solution:**

- If the header adapter does rotate to the right, then press and hold the right header tilt button. Check coil #13 (C). It should magnetize. If not, check Amp connection at the stack valve.
- If this does not correct the problem contact Hillco.
- If the header adapter does rotate to the left, then press and hold the left header tilt button. Check coil #12 (A). It should magnetize. If not, check Amp connection at the stack valve.
- If this does not correct the problem contact Hillco.

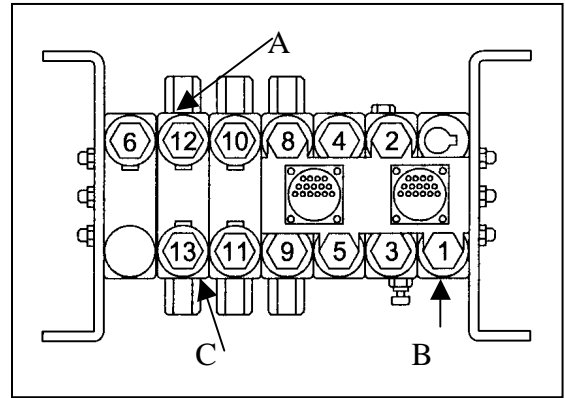

**Problem:** The header adapter does not rotate.

**Solution:**

- With the combine idling, raise the header.
- If the header does not rise, then check the hydro-handle connections.
- If the header raises, then depress and hold the header tilt switch to the right. The coil #1 (B) and coil #13 (C) should magnetize.
  - If the neither coil magnetizes, then reprogram the corner post display.
  - If the coil 1 magnetizes, but coil #13 (C) does not magnetize then recheck the Amp connections at the stack valve.

# Appendix 1

## JD Parts List for Header Tilt Display

<b>FOR 9650 STS, 9750 STS COMBINES</b>		
PART #	QTY	DESCRIPTION
AH162586	1	CABLE
AH163819	1	WIRING HARNESS
AH162585	2	BRACKET
37M7089	2	SCREW
H156936	1	BRACKET
R41076	1	GROMMET
R111692	1	SHAFT
R26871	1	SNAP RING
R112679	1	SEAL
H166313	1	LEVER
P48347	2	O-RING
R86457	1	SUPPORT
RE56165	1	SENSOR
21M7261	2	SCREW
14M7297	2	NUT
34H305	1	SPRING PIN
H168732	2	BALL STUD
14M7397	1	LOCK NUT
37M7084	2	SCREW
19M7862	2	SCREW
14M7303	2	NUT

<b>FOR 94, 95, 9650 WALKER COMBINES</b>		
PART #	QTY	DESCRIPTION
AH162587	1	CABLE (w/AIRFLOW)
AH162588	1	CABLE (w/o AIRFLOW)
AH163819	1	WIRING HARNESS
AH162585	2	BRACKET
37M7089	2	SCREW
H156936	1	BRACKET
R41076	1	GROMMET
R111692	1	SHAFT
R26871	1	SNAP RING
R112679	1	SEAL
H166313	1	LEVER
P48347	2	O-RING
R86457	1	SUPPORT
RE56165	1	SENSOR
21M7261	2	SCREW
14M7297	2	NUT
34H305	1	SPRING PIN
H168732	2	BALL STUD
14M7397	1	LOCK NUT
37M7084	2	SCREW
19M7862	2	SCREW
14M7303	2	NUT