



Hillco Precleaner Install Manual

for Magnum Tier4B Tractors

Models 250, 280, 310, 310 Rowtrac, 340, 340 Rowtrac, 380 & 380 Rowtrac
Kit 1352571

D-150915CMA01B
March, 2023



Statement of Limited Warranty

Class III Warranty

Parts Only

Hillco warrants its Class III products to be free from defects in material and workmanship for a period of twelve (12) consecutive months following the warranty start date.

The warranty start date for Hillco Class III products is the date of the invoice, or the first date of use, whichever is earliest. Once the warranty period has begun, it cannot be stopped or interrupted.

Hillco warrants genuine Hillco replacement parts and components to be free from defects in material and workmanship for a period of ninety (90) consecutive days following the Hillco invoice date, or the remainder of the original equipment warranty period, whichever is longer.

Hillco's obligation under this parts warranty shall be limited to repairing or replacing, any part(s) that, in Hillco's judgment, shows evidence of such defect, to the original purchaser. This parts warranty does not cover any related labor associated with replacing parts deemed to be defective.

Limitations to Warranty

This warranty does not cover:

- 1) Any product damaged by accident, abuse, misuse, negligence, or improper maintenance.
- 2) Any unauthorized product alteration or modification.
- 3) Any unauthorized repairs made with parts other than genuine Hillco parts unless specifically authorized by Hillco.
- 4) Any repairs performed by anyone other than Hillco or an authorized Hillco dealer unless specifically authorized by Hillco.
- 5) Any claims directly resulting from improper installation, except those installations performed by Hillco.
- 6) Any labor costs associated with the defective part(s).

Warranty Procedure

Hillco Class III Warranty Registration Card must be completed and submitted by retail customer within thirty (30) days of purchase.

All warranty work must be performed, and claims submitted, within thirty (30) days of the occurrence of the claim and within the warranty period.

All parts removed during warranty repair should be held for a period of sixty (60) days after the warranty claim has been submitted to Hillco.

Hillco reserves the right to either inspect the product at the original retail purchaser's location, or the authorized Hillco's dealer's location; or require it to be returned to Hillco, transportation charges prepaid, for inspection.

To file a warranty claim, email support@hillcotechologies.com with the following information:

- Your full name and phone number
- Proof of purchase
- Description of issue
- Serial number and/or part number(s) of items needing replaced, and
- If available, include any photos that can assist to describe the issue.

Limitation of Liability

Hillco makes no express warranties other than those, which are specifically described herein. Any description of the goods sold hereunder, including any reference to buyer's specifications and any descriptions in circulars and other media published by Hillco is for the sole purpose of identifying such goods and shall not create an express warranty that the goods shall conform to such description.

THIS WARRANTY IS EXPRESSLY IN LIEU OF ALL OTHER WARRANTIES EXPRESSED OR IMPLIED. There are no implied warranties of merchantability or fitness for a particular purpose. This warranty states Hillco's entire and exclusive liability and buyer's exclusive remedy for any claim for damages in connection with the sale or furnishing of Hillco products, their design, suitability for use, installation, operation, or for any claimed defects herein. **HILLCO WILL IN NO EVENT BE LIABLE FOR ANY INCIDENTAL OR CONSEQUENTIAL DAMAGES WHATSOEVER, NOR FOR ANY SUM IN EXCESS OF THE PRICE RECEIVED FOR THE GOODS FOR WHICH LIABILITY IS CLAIMED.**

Neither representative of Hillco nor any dealer associated with Hillco has the authority to change the items of this warranty in any manner whatsoever, and no assistance to purchaser by Hillco in the repair or operation of any Hillco product shall constitute a waiver of the conditions of this warranty, nor shall such assistance extend or revive it.

Hillco reserves the right to make improvements in design or changes in specifications at any time, without incurring any obligation to owners of units previously sold.

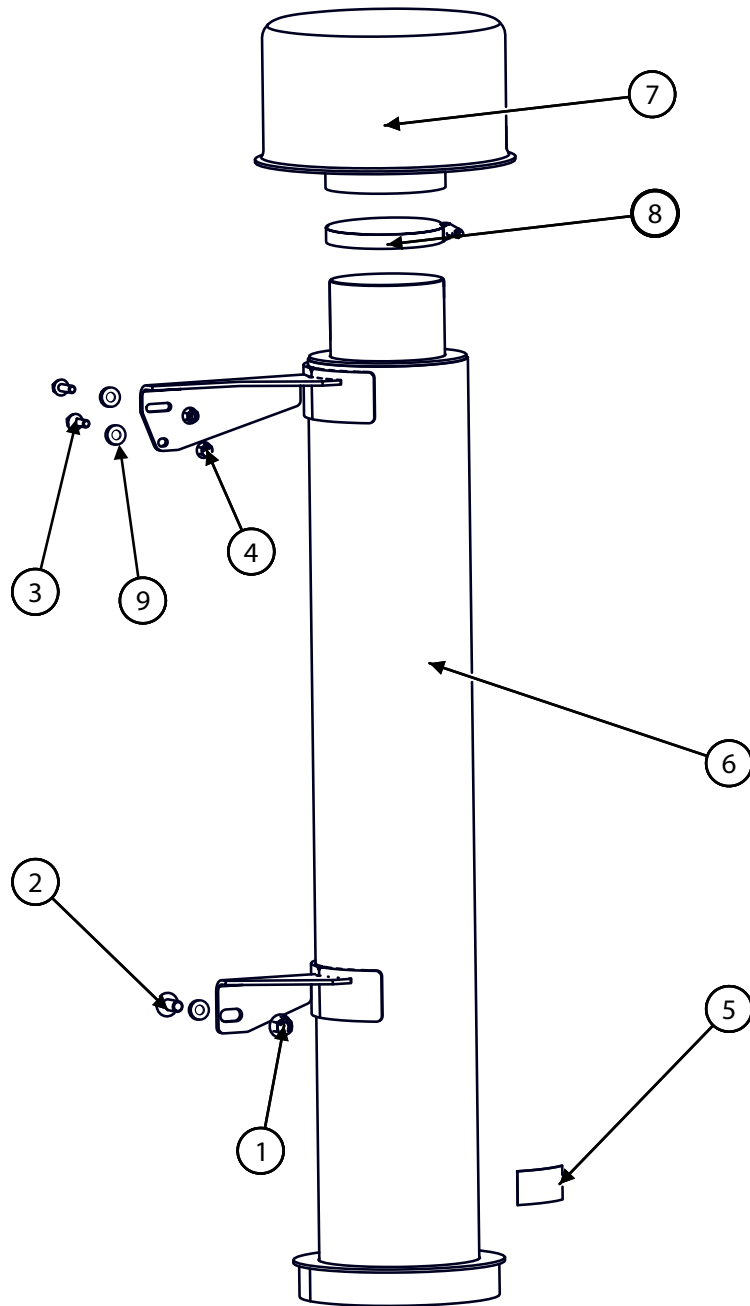

BOM ID	Part Number	Qty	Description
1	123.012	1	NUT, FLANGE M12
2	122.012.030	1	BOLT,HX,FL,CL10.9 M12X30
3	122.008.030	2	BOLT,HX,FL,CL10.9 M8X30
4	123.008	2	NUT, FLANGE M8
5	156137	1	HILLCO LOGO DECAL
6	1352561	1	TUBE, MAGNUM T4B
7	155872	1	EX-60 PRECLEANER, BLACK
8	155508	1	T-BOLT CLAMP 6"
9	148341	3	PAD BUMPER

Remove the original plastic intake tube by removing the two sets of bolts that secure the pre-cleaner to the cab (A). Discard fasteners. The only original mounting hardware left from the two cab mounts are the ears that are welded to the cab.

Loosen the clamp at the bottom of the pre-cleaner (B). Remove pre-cleaner. The clamp will be reused.

Install the intake to the cab using the original mounts on the cab. The top mount (C) will use two M8 x 25 bolts and two M8 nuts.

Place rubber pads (F) between precleaner and cab mounts. This will reduce vibration when precleaner spins.

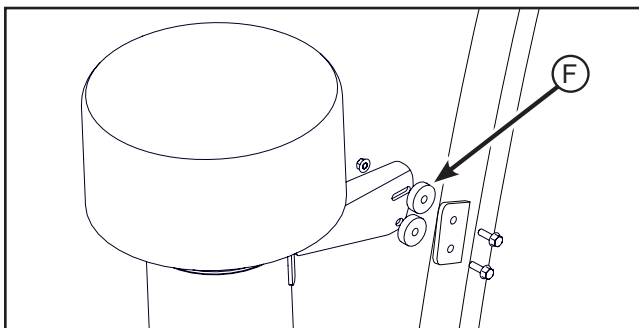

The bottom mount (D) will use 1 M12 x 25 bolt and nut. Install rubber pad between bottom intake mount and cab bracket. The M12 bolt will fit tight into the rubber pad. Leave the mounting bolts loose for now as the intake may need to be shifted around to get the pre-cleaner secured to the top.

Install the rubber boot over the intake and secure with the original clamp (E).



Install the pre-cleaner to the intake tube. Press the intake all the way down onto the tube. Make sure that the slits in the pre-cleaner are covered so that all air entering has to go through the pre-cleaner.

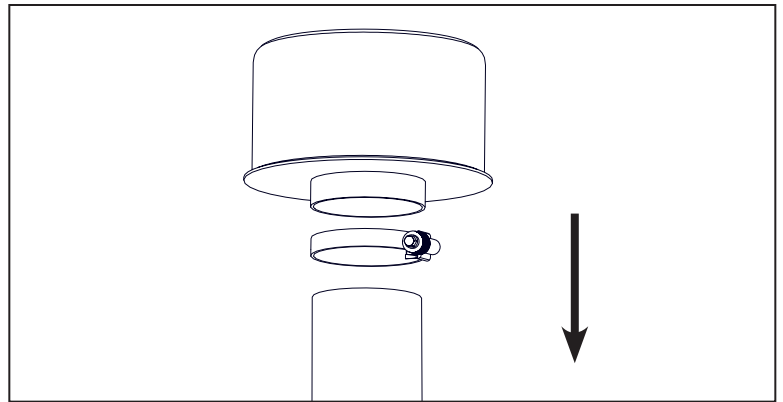

Locate the discharge louver on the side of the pre-cleaner. Rotate the pre-cleaner on the intake tube so that the discharge louver is point to the outside of the tractor.

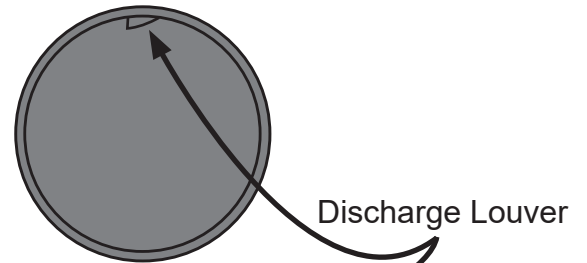

Secure pre-cleaner to intake with the provided 7" clamp. Tighten to 7.5 ft/lbs (90 in. lbs or 1.0369 kg-m)

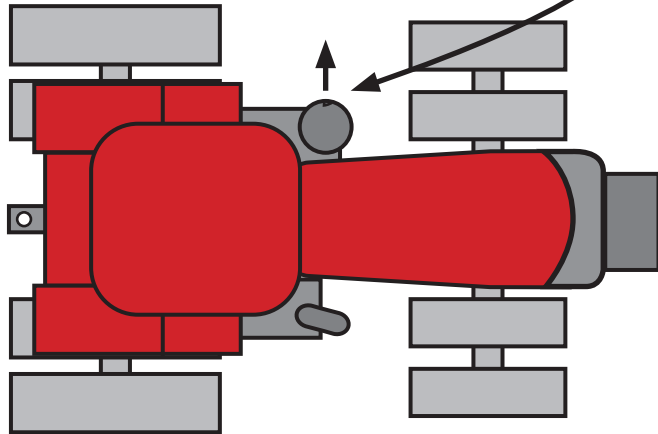

Tighten the intake mounting bolts (A). The holes are slotted to allow the intake to be lined up vertically with the exhaust on the other side of the cab. When it is lined up tighten the two M8 bolts and one M12 bolt.

This completes the install.



Hillco Technologies, Inc.
800-937-2461
1010 1st Avenue, Nezperce, Idaho