



Hillco Air Intake Install Manual
for Steiger Tier4A Tractors Left Mount
Models 350 Row & WH, 400 Row & WH, 450 Row & WH, 500 Row
Kit 1335382

D-160703CMA01B
March, 2021



Statement of Limited Warranty

Class III Warranty

Parts Only

Hillco warrants its Class III products to be free from defects in material and workmanship for a period of twelve (12) consecutive months following the warranty start date.

The warranty start date for Hillco Class III products is the date of the invoice, or the first date of use, whichever is earliest. Once the warranty period has begun, it cannot be stopped or interrupted.

Hillco warrants genuine Hillco replacement parts and components to be free from defects in material and workmanship for a period of ninety (90) consecutive days following the Hillco invoice date, or the remainder of the original equipment warranty period, whichever is longer.

Hillco's obligation under this parts warranty shall be limited to repairing or replacing, any part(s) that, in Hillco's judgment, shows evidence of such defect, to the original purchaser. This parts warranty does not cover any related labor associated with replacing parts deemed to be defective.

Limitations to Warranty

This warranty does not cover:

- 1) Any product damaged by accident, abuse, misuse, negligence, or improper maintenance.
- 2) Any unauthorized product alteration or modification.
- 3) Any unauthorized repairs made with parts other than genuine Hillco parts unless specifically authorized by Hillco.
- 4) Any repairs performed by anyone other than Hillco or an authorized Hillco dealer unless specifically authorized by Hillco.
- 5) Any claims directly resulting from improper installation, except those installations performed by Hillco.
- 6) Any labor costs associated with the defective part(s).

Warranty Procedure

Hillco Class III Warranty Registration Card must be completed and submitted by retail customer within thirty (30) days of purchase.

All warranty work must be performed, and claims submitted, within thirty (30) days of the occurrence of the claim and within the warranty period.

All parts removed during warranty repair should be held for a period of sixty (60) days after the warranty claim has been submitted to Hillco.

Hillco reserves the right to either inspect the product at the original retail purchaser's location, or the authorized Hillco's dealer's location; or require it to be returned to Hillco, transportation charges prepaid, for inspection.

To file a warranty claim, email support@hillcotechologies.com with the following information:

- Your full name and phone number
- Proof of purchase
- Description of issue
- Serial number and/or part number(s) of items needing replaced, and
- If available, include any photos that can assist to describe the issue.

Limitation of Liability

Hillco makes no express warranties other than those, which are specifically described herein. Any description of the goods sold hereunder, including any reference to buyer's specifications and any descriptions in circulars and other media published by Hillco is for the sole purpose of identifying such goods and shall not create an express warranty that the goods shall conform to such description.

THIS WARRANTY IS EXPRESSLY IN LIEU OF ALL OTHER WARRANTIES EXPRESSED OR IMPLIED. There are no implied warranties of merchantability or fitness for a particular purpose. This warranty states Hillco's entire and exclusive liability and buyer's exclusive remedy for any claim for damages in connection with the sale or furnishing of Hillco products, their design, suitability for use, installation, operation, or for any claimed defects herein. **HILLCO WILL IN NO EVENT BE LIABLE FOR ANY INCIDENTAL OR CONSEQUENTIAL DAMAGES WHATSOEVER, NOR FOR ANY SUM IN EXCESS OF THE PRICE RECEIVED FOR THE GOODS FOR WHICH LIABILITY IS CLAIMED.**

Neither representative of Hillco nor any dealer associated with Hillco has the authority to change the items of this warranty in any manner whatsoever, and no assistance to purchaser by Hillco in the repair or operation of any Hillco product shall constitute a waiver of the conditions of this warranty, nor shall such assistance extend or revive it.

Hillco reserves the right to make improvements in design or changes in specifications at any time, without incurring any obligation to owners of units previously sold.

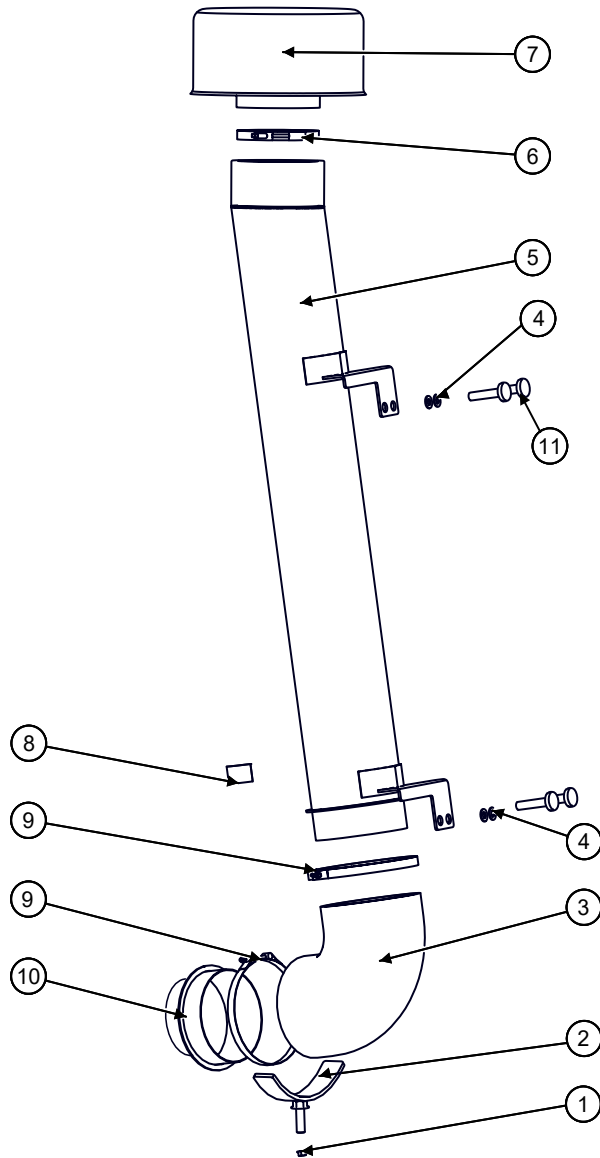

BOM ID	Part Number	Qty	Description
1	123.010	1	NUT,FLANGE,M10
2	1335431	1	MOUNT, ELBOW,
3	155490	1	8" 90° ELBOW, RUBBER
4	133.012	4	WASHER,L9,HD 3/4
5	1335392	1	AI WLD, MAIN TUBE, STEIGER,T4A
6	155511	1	T-BOLT CLAMPS FIT 8" OD TUBE
7	155683	1	EX-80 PRECLEANER, BLACK
8	155516	1	HILLCO LOGO DECAL
9	155512	2	T-BOLT CLAMPS FIT 9" OD TUBE
10	1335471	1	CONNECTOR, 8 INCH TO 6 INCH
11	122.010.050	4	BOLT,HX,FL,CL10.9 M10X50

Remove the original plastic air intake tube by removing the bolts that secure the intake to the cab (A). Discard fasteners.

Loosen the clamp at the bottom of the air intake tube. The clamp will be reused.

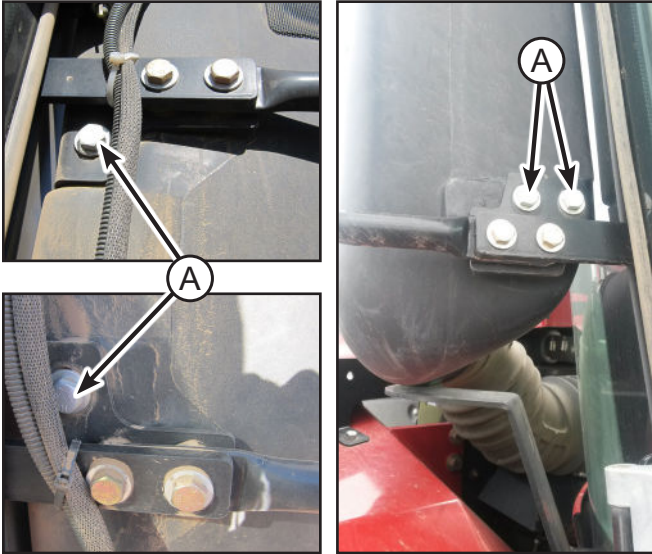

Remove the 3 bolts that secure the bottom of the air intake to the mount.

Remove plastic air intake tube.

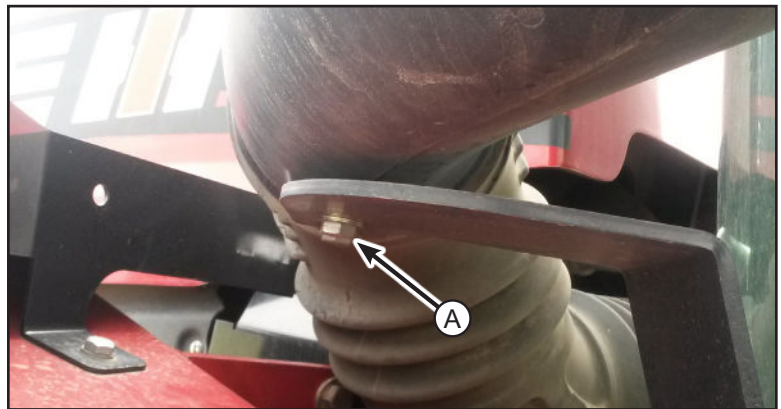

Remove the air intake mounts (C) from the handrail mounts. The mounts may be frozen to the isolators. Use a prybar to remove the mount. The isolator and other fasteners will be reused.

Note: Do not grab onto the handrail as it is not secured.



Secure the bottom mount (A) to the original mount using the M10 Bolt. Do not tighten at this time. The rubber elbow will sit on this mount.

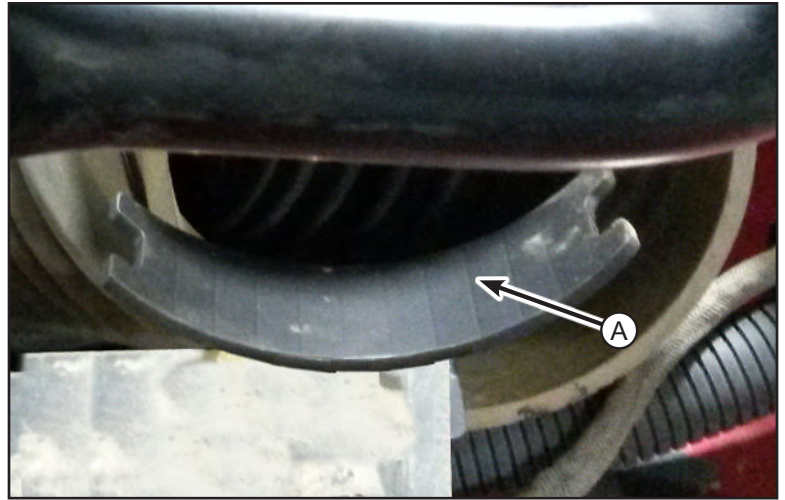
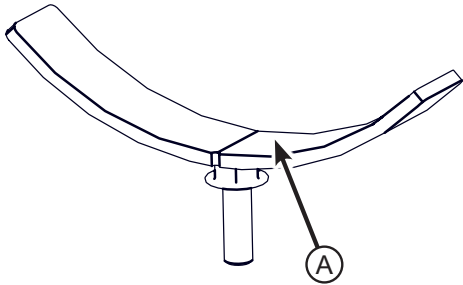

Install the adapter (B) to the elbow (C). Install a clamp around the elbow and tighten. Install the elbow to the intake tube (D). Spray intake tube with lubricant to ease installation and to be able to rotate later into the correct position.

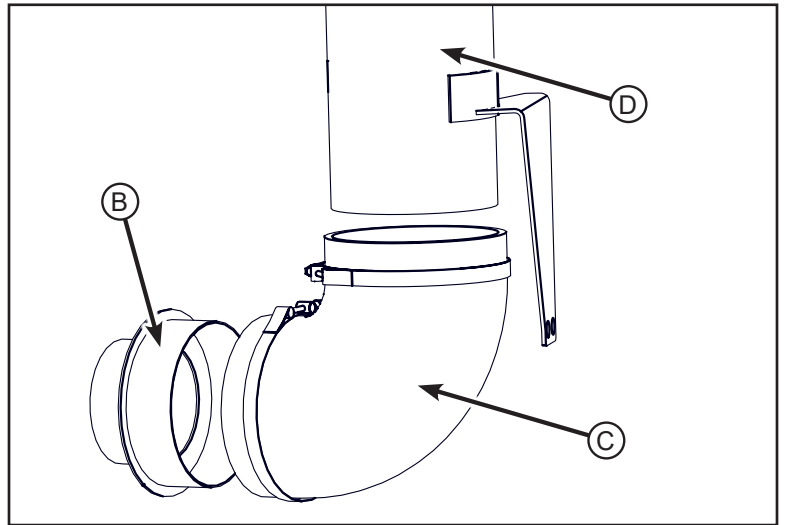

Replace the M10 X 40 bolts (A) on the handle bar bracket with M10 X 50 bolts (B).

Discard M10 X 40 Bolts. Remove the rubber isolators. See next page for additional view.

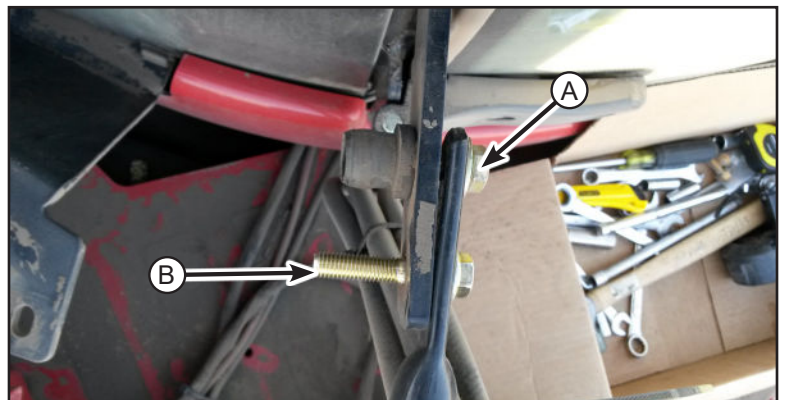

Install the 3/4 inch ID washers (C) over isolators (D) and then insert the isolators into the holes in the hillco intake tube. Do this for all 4 isolators. See below diagram

The washers will take up space so that when the Hillco Airflow system is installed it is tightly secured to the handrail mounts.

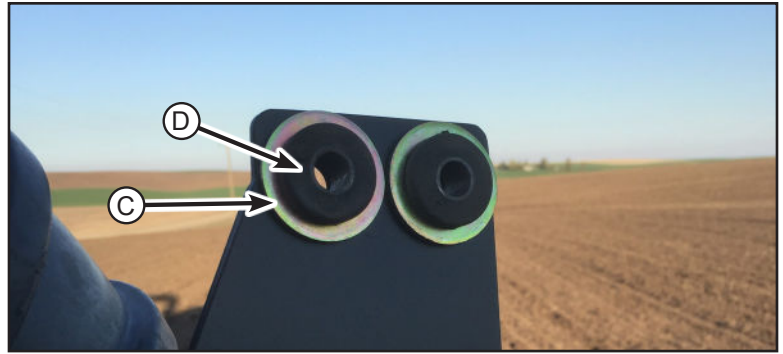

Install the intake tube into the bottom boot. Then align the four mounting holes on the intake tube to the front side of the four handrail mounting bolts as shown. See pictures on the following page.

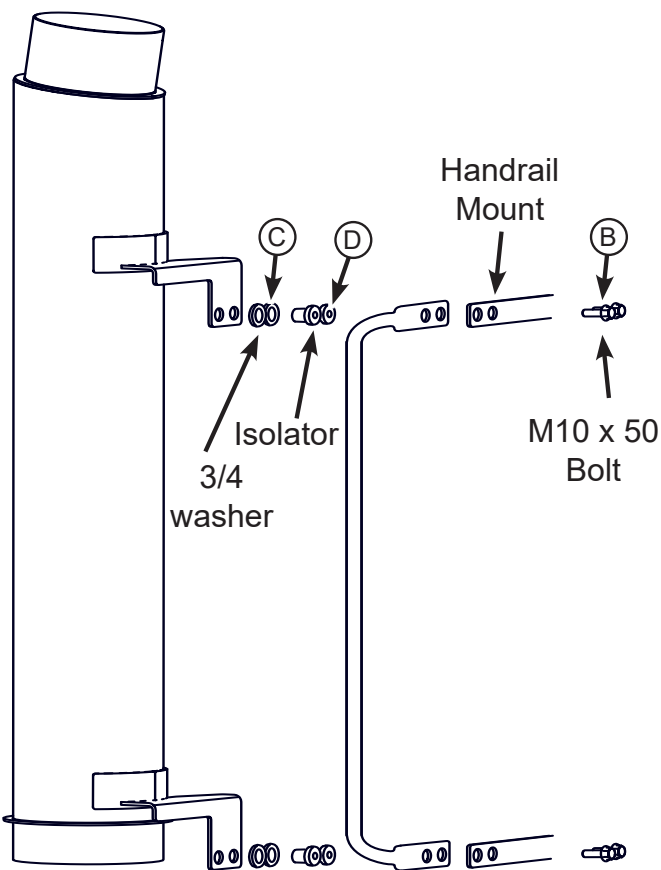

This is a view from the back side of the mounts.

- B - Original Bolts and Washers
- C - Cab Mounts
- D - Handrail
- E - Rubber Isolator
- F - Hillco 3/4 inch ID Washer
- G - Hillco Intake Mount

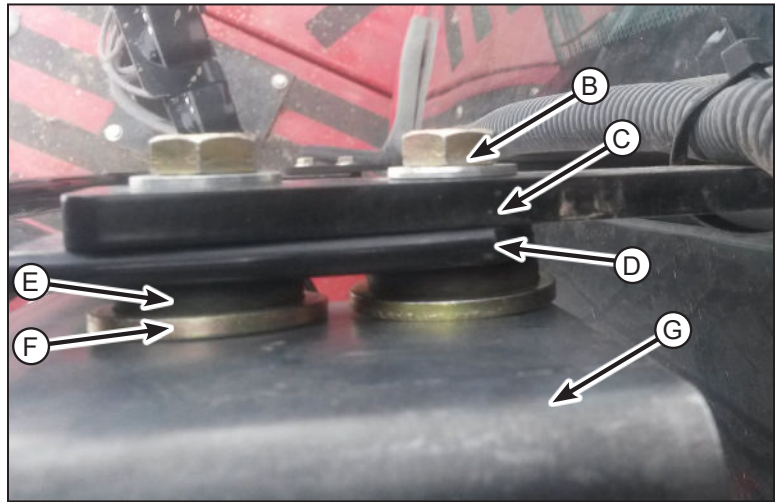

Secure the intake mounts with the original washers and nuts. Tighten to prevailing torque.



Install the bellow tube over the adapter ring (J).

Tighten original clamp on bellow (I).

Tighten the clamps (H) on the elbow. Tighten the bolt on the bottom support.

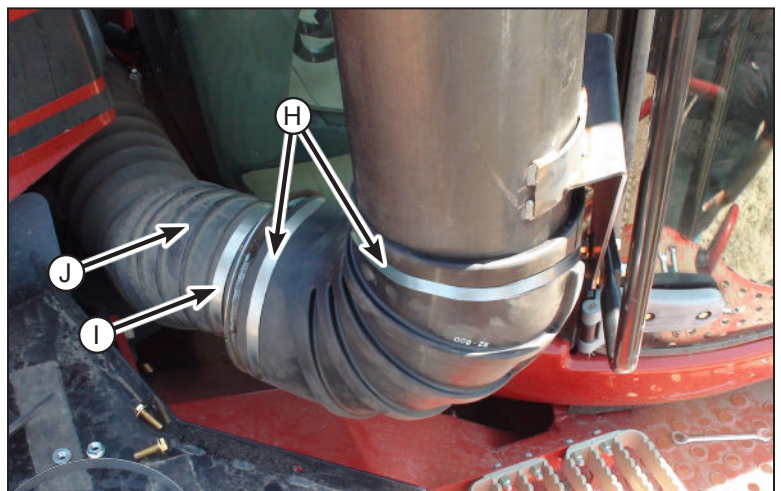

Install the pre-cleaner to the intake tube. Press the intake all the way down onto the tube. Make sure that the slits in the pre-cleaner are covered so that all air entering has to go through the pre-cleaner.

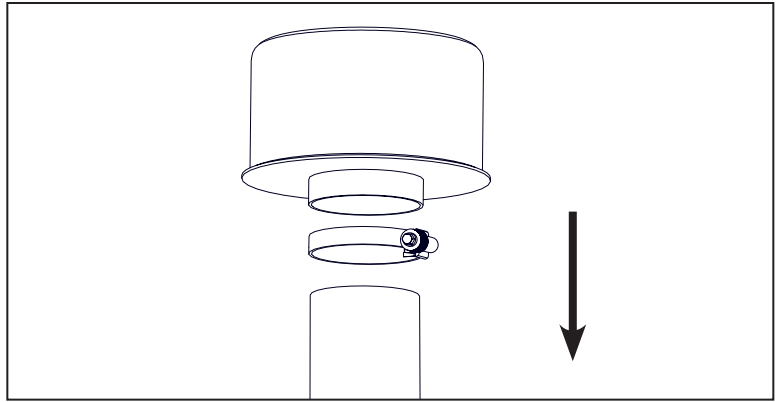
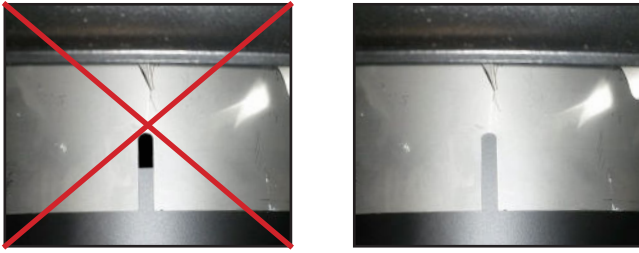

Locate the discharge louver on the side of the pre-cleaner. Rotate the pre-cleaner on the intake tube so that the discharge louver is point to the outside of the tractor.

Secure pre-cleaner to intake with the provided 8" clamp. Tighten to 7.5 ft/lbs (90 in. lbs or 1.0369 kg-m)

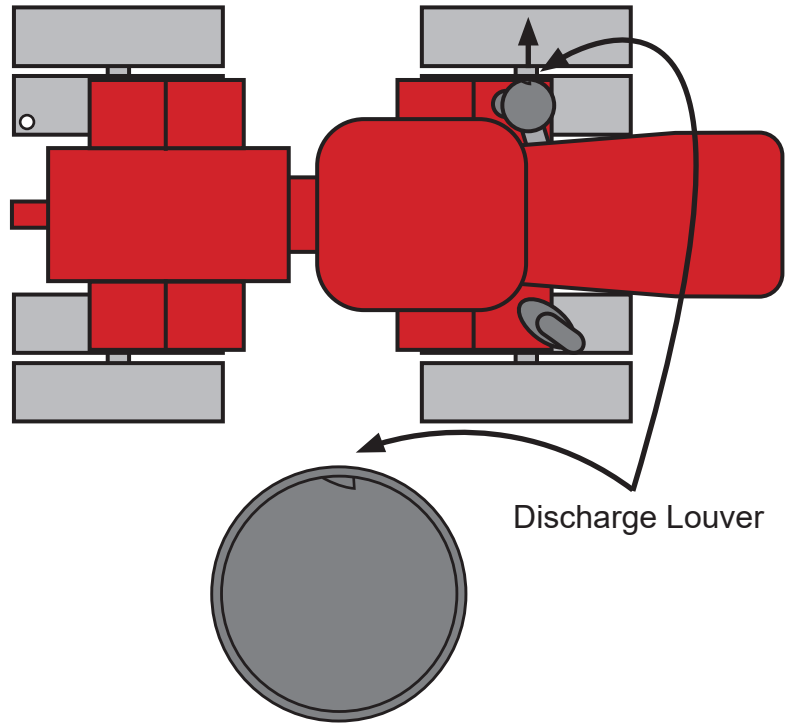

Make sure all clamps are tight.

For maximum performance with your Hillco Air Flow System, install a new air filter element, check air intake system for leaks or damage and repair as necessary.

This completes the install.

Hillco Technologies, Inc.
800-937-2461
1010 1st Avenue, Nezperce, Idaho
8